VLT[®] Series 3500
Adjustable Frequency Drive
Instruction Manual

VLT[®] Series 3500 Instruction Manual

175R5237 - Document Version 5.00

This manual applies to all VLT[®] Series 3502-3800 Adjustable Frequency Drives with software version 3.02 and 3.12 or newer. To determine software version refer to Parameter 603, Name Plate.



WARNING:

Touching the electrical parts, even when the AC line has been disconnected, can cause serious injury or death. Before touching any electrical components wait at least:

4 minutes for VLT 3502-3532, 230V; 3502-3562, 460V,
14 minutes for VLT types 3542-3562, 230V,
14 minutes for VLT types 3575-3800, all voltages.

Table of Contents

| | |
|-------------------------------------------------------------|---------|
| Safety Guidelines | 4 |
| Warnings Against Unintended Start | 4 |
| Specification Charts | 5 |
| Dimensions | 10 |
| General | 23 |
| VLT Type 3052-3562 | 23 |
| VLT Type 3575-3700 and 3542-3562 | 23 |
| Base for VLT Type 3625-3800 | 23 |
| Hinged Door on VLT Type 3575-3800 | 24 |
| Auxiliary Enclosures | 25 |
| Cooling | 25 |
| Input Power Wiring | 26 |
| Shielded Wires | 26 |
| Power Terminals | 27 |
| Motor Connections | 30 |
| Parallel Connection of Motors | 30 |
| Terminal Block Locations | 31 |
| Programmable Terminal Functions | 31 |
| Control Card Terminals | 32 |
| Electrical Noise | 33 |
| Installation of Units with Optional EMI Filter Module | 34 |
| Shielded Wiring | 34 |
| Wiring and Setup Examples | 35 - 44 |
| Control Panel | 44 |
| Local/Hand and Remote/Auto Control | 44 |
| External Selection of Local/Hand and Remote/Auto | 44 |
| External Local/Hand and Remote/Auto References | 44 |
| Start Signal for External hand Mode | 44 |
| External Remote/Auto Mode | 24 |
| How to Operate VLT Series 3500 | 45 |
| The VLT Display | 45 |
| Remote Mounting of the Control Panel | 45 |
| The Keypad Switches | 45 |
| Keys for Local Operation | 46 |
| Display Mode | 47 |
| Programming | 47 |
| Functions of the Keys | 48 |
| Combinations of Control Panel Keys | 48 |
| Display Mode | 49 |
| Quick Setup Mode | 49 |
| Quick Setup Data Mode | 49 |
| Extended Menu Mode | 49 |
| Extended Parameter Mode | 50 |
| Extended Data Mode | 50 |
| Local/Hand Mode | 50 |
| Alarm Mode | 50 |
| Menu Access Keys | 51 |

Table of Contents

| | |
|-------------------------------------------|----|
| Drive Setup | 52 |
| Return to Factory Defaults | 52 |
| Lockout | 52 |
| Standard HVAC Operation Parameters | 53 |
| Extended Menu Structure | 54 |
| Parameter Numbers | 54 |
| Accessing the Various Parameters | 54 |
| Changing the Parameter Data Value | 54 |
| Leaving Data Mode | 54 |
| Speed Control Signal -- Open Loop | 55 |
| Speed Control Signal -- Closed Loop | 56 |
| Parameter Groups Table | 57 |
| Programming | 58 |
| Group 0 -- Operation and Display | |
| Parameters 000 - 002 | 58 |
| Parameters 003 - 008 | 59 |
| Parameters 009 - 014 | 60 |
| Parameters 015 | 61 |
| Group 1 -- Load and Motor | |
| Parameters 100 - 101 | 62 |
| Parameters 102 - 104 | 63 |
| Parameters 105 - 114 | 64 |
| Parameters 115 - 119 | 65 |
| Parameters 120 - 125 | 66 |
| Group 2 -- References and Limits | |
| Parameters 201 - 204 | 67 |
| Parameters 205 - 210 | 68 |
| Parameters 211 - 216 | 69 |
| Parameters 217 - 224 | 70 |
| Parameters 225 - 232 | 71 |
| Group 3 -- Functions and Timers | |
| Parameters 301 - 305 | 72 |
| Parameters 306 - 309 | 73 |
| Parameters 310 - 314 | 74 |
| Parameters 315 - 317 | 75 |
| Group 4 -- Inputs and Outputs | |
| Parameters 400 - 401 | 76 |
| Parameters 402 - 403 | 77 |
| Parameters 403 - 404 | 78 |
| Parameter 405 | 79 |
| Parameter 406 | 80 |
| Parameter 407 | 81 |
| Parameters 408 - 409 | 82 |
| Parameters 410 - 412 | 83 |
| Parameters 413 - 420 | 84 |

Table of Contents

| | |
|------------------------------------------------|-----------|
| Group 5 -- Serial Data Interface | 85 |
| Bytes 1 22 | 86 |
| Control Word | 87 |
| Bit 00 - 04 | 87 |
| Bit 05 - 14 | 88 |
| Bit 15 | 89 |
| Status Word | 89 |
| Bit 00 - 14 | 90 |
| Bit 15 | 91 |
| Message Example | 91 |
| Response Message | 92 |
| Fault Messages | 92 |
| Switch 04 | 92 |
| Parameters 500 - 502 | 93 |
| Parameter 502 (continued) | 94 |
| Parameters 503 - 510 | 95 |
| Parameters 510 (continued) - 517 | 96 |
| Group 6 -- Service and Diagnostics | |
| Parameters 600 - 601 | 97 |
| Parameters 602 - 603 | 98 |
| Parameter 604 | 99 |
| Parameters 605 - 650 | 100 |
| Status Messages | 101 |
| Warning Messages | 102 |
| Reset Messages | 103 |
| Alarm Messages | 103 |
| Fault Messages | 104 - 105 |
| Electrostatic Discharges | 105 |
| Troubleshooting | 106 - 108 |
| External Mounting of Display | 109 |
| Installation of Option Cards | 109 |
| Mounting of Optional Fan | 109 |
| Appendix 1 Field Terminal Connections | 110 |
| Appendix 2 PI Regulation | 111 |
| Index | 114 |
| Factory Default Parameter Settings Chart | 122 |
| Customer Parameter Settings Chart | 123 |

DANGER

Touching the electrical parts may be fatal - even after the equipment has been disconnected from the AC line. To be sure that the capacitors have fully discharged, wait 14 minutes after power has been removed before touching any internal component.

DANGER

Rotating shafts and electrical equipment can be hazardous. Therefore, it is strongly recommended that all electrical work conform to the National Electrical Code and all local regulations. Installation, start-up and maintenance should be performed only by qualified personnel.

Although shaft couplings or belt drives are generally not furnished by the manufacturer, rotating shafts, couplings and belts must be protected with securely mounted metal guards that are of sufficient thickness to provide protection against flying particles such as keys, bolts and coupling parts. Even when the motor is stopped, it should be considered "alive" as long as its controller is energized. Automatic circuits may start the motor at any time. Keep hands away from the output shaft until the motor has completely stopped and power is disconnected from the controller.

Motor control equipment and electronic controls are connected to hazardous line voltages. When servicing drives and electronic controls, there will be exposed components at or above line potential. Extreme care should be taken to protect against shock. Stand on an insulating pad and make it a habit to use only one hand when checking components. Always work with another person in case of an emergency. Disconnect power whenever possible to check controls or to perform maintenance. Be sure equipment is properly grounded. Wear safety glasses whenever working on electric control or rotating equipment.

Safety Guidelines

1. The drive must be disconnected from the AC line before any service work is done.
2. The "Stop/Reset" key on the operating panel of the drive does not disconnect the equipment from the AC line and is not to be used as a safety switch.
3. Correct protective grounding of the equipment must be established. The user must be protected against supply voltage, and the motor must be protected against overload in accordance with applicable national and local regulations.
4. Ground currents are higher than 3 mA.

Warnings against unintended start

1. The motor can be brought to a stop by means of digital commands, bus commands, references or a local stop, while the drive is connected to the AC line. If personal safety considerations make it necessary to ensure that no unintended start occurs, these stops are not sufficient.
2. During programming of parameters, the motor may start. Consequently, the "Stop/Reset" stop key must always be activated, following which data can be modified.
3. A motor that has been stopped may start if faults occur in the electronics of the drive, or if a temporary overload, a fault in the supply AC line or a fault in the motor connection clears.
4. If the "Local/Hand" key is activated and the "Local" reference is modified, the motor can only be brought to a stop by means of the "Stop/Reset" key.

NOTE: It is the responsibility of the user or person installing the drive to provide proper grounding and branch circuit protection for incoming power and motor overload according to the National Electrical Code (NEC) and local codes.

The Electronic Thermal Relay (ETR) in UL listed VLTs provides Class 20 motor overload protection in accordance with NEC in single motor applications, when parameter 315 is set for "TRIP", *parameter 311 is set of "0"*, and parameter 107 is set for rated motor (nameplate) current.



Danfoss VLT[®] and CE Marking

Danfoss CE marks our VLT[®] Adjustable Frequency Drives (AFD) according to the Electro Magnetic Compatibility (EMC) Directive 89/336/EEC and Low-Voltage Directive 73/23/EEC.

When the installation specification is followed and shielded motor cables are used per instruction manuals provided with the drive, we guarantee the AFD complies with the EMC Directive 89/336/EEC. Please consult the RFI Filter Product Manual and EMC Installation Guidelines (175R5187).

Upon request we will issue a declaration of conformity to the EMC and low-voltage directives. A manufacturer's declaration for the Machinery Directive 89/392/EEC is also available.

3 Phase, 200/220/230 Volt, Units

| | | VLT type | 3502 | 3504 | 3508 | 3511 | 3516 | 3522 | 3532 | 3542 | 3552 | 3562 | |
|-------------------------------------------------------------------------------------|----------------------------------------------------|------------------------------------------------------------------------------|-----------------------------------------------------------------------------------------------------------------------------------------------------|------|------|------|------|------|-------------------|-------------------|-------------------|-------------------|------|
|  | Output current | $I_{VLT,N}$ [A] | 5.4 | 10.6 | 25.0 | 32.0 | 46.0 | 61.0 | 88.0 | 104.0 | 130.0 | 154.0 | |
| | | $I_{VLT,MAX}$ (60 s) [A] | 5.9 | 11.7 | 27.3 | 35.2 | 50.6 | 67.3 | 96.8 | 114.4 | 143.0 | 169.0 | |
| | Output | $S_{VLT,N}$ [kVA] | 1.9 | 4.0 | 10.0 | 12.7 | 18.3 | 24.3 | 35.1 | 41.4 | 51.8 | 61.3 | |
| | Typical shaft output | $P_{VLT,N}$ [HP] | 1 | 3 | 5 | 10 | 15 | 20 | 30 | 40 | 50 | 60 | |
| | Max. cable cross-section | [AWG] | 12 | 12 | 6 | 6 | 6 | 4 | 4 | 2/0 | 2/0 | 2/0 | |
| | Max. motor cable length | [feet] | 1000 (unshielded)* | | | | | | | | | | |
| | Output voltage | V_M [%] | 1-100, of AC line voltage | | | | | | | | | | |
| | Output frequency | f_M [Hz] | 0-120 | | | | | | | | | | |
| | Rated motor voltage | $V_{M,N}$ [V] | 200/220/230 | | | | | | | | | | |
| | Rated motor frequency | $f_{M,N}$ [Hz] | 50/60/87/100 | | | | | | | | | | |
| | Thermal protection during operation | | Integrated thermal motor protection (electronic); thermistor to DIN44081 | | | | | | | | | | |
| | Switching on output | | Unlimited (frequent switching may cause cut-out) | | | | | | | | | | |
| | Ramp times | [s] | 0.1-3600 | | | | | | | | | | |
| | | VLT type | 3502 | 3504 | 3508 | 3511 | 3516 | 3522 | 3532 | 3542 | 3552 | 3562 | |
|  | Max. input current | $I_{L,N}$ [A] | 5.4 | 10.6 | 23.1 | 29.6 | 42.0 | 56.8 | 72.3 | 102.0 | 128.0 | 152.0 | |
| | Max. cable cross-section | [AWG] | 12 | 12 | 6 | 6 | 6 | 4 | 4 | 2/0 | 2/0 | 2/0 | |
| | Max. pre-fuses | [A] | 25 | 25 | 40 | 50 | 60 | 80 | 125 ¹⁾ | 150 ²⁾ | 150 ²⁾ | 150 ²⁾ | |
| | Supply voltage | [V] | 3 phase 200/220/230 ±10% | | | | | | | | | | |
| | Supply frequency | [Hz] | 50/60 | | | | | | | | | | |
| | Power factor / cos φ | | 0.9/1.0 | | | | | | | | | | |
| | Efficiency | | 0.96 at 100% load | | | | | | | | | | |
| | Switching on input | times/min. | 2 | | | | | | | | | | |
| | Radio noise, cable borne (with shielded cables) | | VLT type 3502-04: EN 55011, class A, gr. 1, with option class B. gr 1 VLT type 3508-32 with option: EN 55011, cl. A, 1 VDE 0875, part 3, curve N | | | | | | | | | | |
| | | | VLT type | 3502 | 3504 | 3508 | 3511 | 3516 | 3522 | 3532 | 3542 | 3552 | 3562 |
|  | Weight (lbs) | Chassis (IP00) | 16 | 16 | – | – | – | – | – | – | – | – | |
| | and enclosure type | NEMA 1 (IP 20) | – | – | 53 | 57 | 70 | 108 | 112 | 315 | 319 | 323 | |
| | | NEMA 1 (IP 21) | 18 | 18 | – | – | – | – | – | – | – | – | |
| | | NEMA 12 (IP 54) | 24 | 24 | 75 | 81 | 106 | 139 | 143 | 315 | 319 | 323 | |
| Power loss at max. load [W] | | Front | – | – | – | – | – | – | – | 357 | 394 | 409 | |
| | | Heat sink | – | – | – | – | – | – | – | 588 | 712 | 884 | |
| | | Total | 60 | 130 | 425 | 580 | 651 | 929 | 1350 | 945 | 1106 | 1293 | |
| Vibration test | [g] | 0.7 | | | | | | | | | | | |
| Relative humidity | [%] | VDE 0160 5.2.1.2. | | | | | | | | | | | |
| Ambient temperature | [°C] | –10 → +40. operation at full load ¹⁾ | | | | | | | | | | | |
| | | –30/25 → +65/70, storage/transport | | | | | | | | | | | |
| Adjustable frequency drive protection | | Protection against grounding and short-circuiting | | | | | | | | | | | |
| EMC standards | Emission | EN 50011, VDE 0875 part 3 | | | | | | | | | | | |
| | Immunity | EN 50082-2, IEC 801-2, IEC 801-3, IEC 801-4, IEC 801-5, VDE 0160, SEN 361503 | | | | | | | | | | | |

* If shielded cable is to be used, consult Danfoss for cable length.

1) In the range –10 to 0°C, the equipment can start and run; however, the display values and certain operating characteristics will not fulfill the specifications.

2) Bussmann rapid type JJS integrated.

3 Phase, 380/400/415 Volt, Units

| | | VLT type | 3502 | 3504 | 3505 | 3508 | 3511 | 3516 | 3522 | 3532 | 3542 | 3552 | 3562 |
|---------------------------------------|----------------------------------------------------|------------------------------------------------------------------------------|----------------------------------------------------------------------------|------|------|------|------|------|------|------|------|------|------|
| | Output current | $I_{VLT,N}$ [A] | 2.8 | 5.6 | 7.3 | 13.0 | 16.0 | 24.0 | 31.9 | 44.2 | 61.0 | 73.2 | 88.0 |
| | | $I_{VLT,MAX}$ (60 s) [A] | 3.1 | 6.2 | 8.0 | 14.3 | 17.6 | 26.4 | 35.2 | 48.4 | 67.1 | 80.3 | 96.8 |
| | Output | $S_{VLT,N}$ [kVA] | 2.0 | 4.0 | 5.2 | 9.3 | 11.5 | 17.2 | 22.9 | 31.8 | 44.0 | 52.5 | 63.3 |
| | Typical shaft output | $P_{VLT,N}$ [kW] | 1.1 | 2.2 | 3 | 5.5 | 7.5 | 11 | 15 | 22 | 30 | 37 | 45 |
| | Max. cable cross-section | [AWG] | 12 | 12 | 12 | 12 | 12 | 6 | 6 | 6 | 2 | 2 | 1/0 |
| | Max. motor cable length | [feet] | 1000 (unshielded)* | | | | | | | | | | |
| | Output voltage | V_M [%] | 1-100, of AC line voltage | | | | | | | | | | |
| | Output frequency | f_M [Hz] | 0-120 | | | | | | | | | | |
| | Rated motor voltage | $V_{M,N}$ [V] | 380/400/415 | | | | | | | | | | |
| | Rated motor frequency | $f_{M,N}$ [Hz] | 50/60/87/100 | | | | | | | | | | |
| | Thermal protection during operation | | Integrated thermal motor protection (electronic); thermistor to DIN44081 | | | | | | | | | | |
| | Switching on output | | Unlimited (frequent switching may cause cut-out) | | | | | | | | | | |
| | Ramp times | [s] | 0.1-3600 | | | | | | | | | | |
| | | | VLT type | 3502 | 3504 | 3505 | 3508 | 3511 | 3516 | 3522 | 3532 | 3542 | 3552 |
| | Max. input current | $I_{L,N}$ [A] | 2.8 | 5.6 | 7.3 | 13.0 | 17.0 | 22.0 | 31.0 | 41.5 | 57.5 | 66.5 | 80.0 |
| | Max. cable cross-section | [AWG] | 12 | 12 | 12 | 12 | 12 | 6 | 6 | 6 | 2 | 2 | 1/0 |
| | Max. pre-fuses | [A] | 16 | 16 | 16 | 25 | 25 | 50 | 63 | 63 | 80 | 100 | 125 |
| | Supply voltage | [V] | 3 phase 380/400/415 ±10% | | | | | | | | | | |
| | Supply frequency | [Hz] | 50/60 | | | | | | | | | | |
| | Power factor / cos φ | | 0.9/1.0 | | | | | | | | | | |
| | Efficiency | | 0.96 at 100% load | | | | | | | | | | |
| | Switching on input | times/min. | 2 | | | | | | | | | | |
| | Radio noise, cable borne (with shielded cables) | | VLT type 3502-11: EN 55011, class A, gr. 1, with option class B. gr 1 | | | | | | | | | | |
| | | | VLT type 3516-62 with option: EN 55011, cl. A, 1 VDE 0875, part 3, curve N | | | | | | | | | | |
| | | VLT type | 3502 | 3504 | 3505 | 3508 | 3511 | 3516 | 3522 | 3532 | 3542 | 3552 | 3562 |
| | Weight (lbs) | Chassis (IP00) | 16 | 16 | 16 | 26 | 31 | – | – | – | – | – | – |
| | and | NEMA 1 (IP 20) | – | – | – | – | – | 53 | 57 | 70 | 108 | 119 | 119 |
| | enclosure type | NEMA 1 (IP 21) | 18 | 18 | 18 | 29 | 33 | – | – | – | – | – | – |
| | | NEMA 12 (IP 54) | 24 | 24 | 24 | 31 | 33 | 75 | 81 | 106 | 139 | 152 | 152 |
| Power loss at max. load | [W] | 60 | 100 | 130 | 280 | 300 | 425 | 580 | 880 | 1390 | 1875 | 2155 | |
| Vibration test | [g] | 0.7 | | | | | | | | | | | |
| Relative humidity | [%] | VDE 0160 5.2.1.2. | | | | | | | | | | | |
| Ambient temperature | [°C] | –10 → +40, operation at full load ¹⁾ | | | | | | | | | | | |
| | | –30/25 → +65/70, storage/transport | | | | | | | | | | | |
| Adjustable frequency drive protection | | Protection against grounding and short-circuiting | | | | | | | | | | | |
| EMC standards | Emission | EN 50011, VDE 0875 part 3 | | | | | | | | | | | |
| | Immunity | EN 50082-2, IEC 801-2, IEC 801-3, IEC 801-4, IEC 801-5, VDE 0160, SEN 361503 | | | | | | | | | | | |

* If shielded cable is to be used, consult Danfoss for cable length.

1) In the range –10 to 0°C, the equipment can start and run; however, the display values and certain operating characteristics will not fulfill the specifications.

3 Phase, 440/460/500 Volt, Units

| | | VLT type | 3502 | 3504 | 3506 | 3508 | 3511 | 3516 | 3522 | 3532 | 3542 | 3552 | 3562 |
|---------------------------------------|----------------------------------------------------|------------------------------------------------------------------------------|----------------------------------------------------------------------------|------|------|------|------|------|------|------|------|------|------|
| | Output current | $I_{VLT,N}$ [A] | 2.6 | 4.8 | 8.2 | 12.6 | 14.4 | 21.7 | 37.9 | 41.4 | 54.0 | 65.0 | 78.0 |
| | | $I_{VLT,MAX}$ (60 s) [A] | 2.9 | 5.3 | 9.0 | 13.9 | 15.9 | 24.0 | 30.7 | 45.8 | 59.6 | 71.5 | 85.8 |
| | Output | $S_{VLT,N}$ [kVA] | 1.6 | 4.1 | 7.1 | 9.6 | 12.4 | 18.8 | 24.2 | 35.9 | 46.8 | 56.3 | 67.5 |
| | Typical shaft output | $P_{VLT,N}$ [HP] | 1 | 3 | 5 | 7.5 | 10 | 15 | 20 | 30 | 40 | 50 | 60 |
| | Max. cable cross-section | [AWG] | 12 | 12 | 12 | 12 | 6 | 6 | 6 | 6 | 4 | 4 | 4 |
| | Max. motor cable length | [feet] | 1000 (unshielded)* | | | | | | | | | | |
| | Output voltage | V_M [%] | 1-100, of AC line voltage | | | | | | | | | | |
| | Output frequency | f_M [Hz] | 0-120 | | | | | | | | | | |
| | Rated motor voltage | $V_{M,N}$ [V] | 440/460/500 | | | | | | | | | | |
| | Rated motor frequency | $f_{M,N}$ [Hz] | 50/60/87/100 | | | | | | | | | | |
| | Thermal protection during operation | | Integrated thermal motor protection (electronic); thermistor to DIN44081 | | | | | | | | | | |
| | Switching on output | | Unlimited (frequent switching may cause cut-out) | | | | | | | | | | |
| | Ramp times | [s] | 0.1-3600 | | | | | | | | | | |
| | | VLT type | 3502 | 3504 | 3506 | 3508 | 3511 | 3516 | 3522 | 3532 | 3542 | 3552 | 3562 |
| | Max. input current | $I_{L,N}$ [A] | 2.6 | 4.8 | 8.2 | 11.1 | 14.4 | 19.6 | 26.0 | 34.8 | 48.6 | 53.0 | 72.0 |
| | Max. cable cross-section | [AWG] | 12 | 12 | 12 | 12 | 6 | 6 | 6 | 6 | 4 | 4 | 4 |
| | Max. pre-fuses | [A] | 20 | 20 | 25 | 25 | 30 | 30 | 40 | 50 | 60 | 100 | 125 |
| | Supply voltage | [V] | 3 phase, 440/460/500 ±10% (VDE 0160) | | | | | | | | | | |
| | Supply frequency | [Hz] | 50/60 | | | | | | | | | | |
| | Power factor / cos φ | | 0.9/1.0 | | | | | | | | | | |
| | Efficiency | | 0.96 at 100% load | | | | | | | | | | |
| | Switching on input | times/min. | 2 | | | | | | | | | | |
| | Radio noise, cable borne (with shielded cables) | | VLT type 3502-08: EN 55011, class A, gr. 1, with option class B. gr 1 | | | | | | | | | | |
| | | | VLT type 3516-62 with option: EN 55011, cl. A, 1 VDE 0875, part 3, curve N | | | | | | | | | | |
| | | VLT type | 3502 | 3504 | 3506 | 3508 | 3511 | 3516 | 3522 | 3532 | 3542 | 3552 | 3562 |
| | Weight (lbs) and enclosure type | Chassis (IP00) | 16 | 16 | 26 | 31 | 31 | – | – | – | – | – | – |
| | | NEMA 1 (IP 20) | – | – | – | – | – | 55 | 57 | 68 | 108 | 119 | 119 |
| | | NEMA 1 (IP 21) | 18 | 18 | 29 | 33 | 33 | – | – | – | – | – | – |
| | | NEMA 12 (IP 54) | 24 | 24 | 31 | 33 | 33 | 75 | 81 | 106 | 139 | 152 | 152 |
| Power loss at max. load | [W] | 60 | 130 | 160 | 200 | 240 | 281 | 369 | 880 | 1133 | 1440 | 1888 | |
| Vibration test | [g] | 0.7 | | | | | | | | | | | |
| Relative humidity | [%] | VDE 0160 5.2.1.2. | | | | | | | | | | | |
| Ambient temperature | [°C] | –10 → +40, operation at full load ¹⁾ | | | | | | | | | | | |
| | | –30/25 → +65/70, storage/transport | | | | | | | | | | | |
| Adjustable frequency drive protection | | Protection against grounding and short-circuiting | | | | | | | | | | | |
| EMC standards | Emission | EN 50011, VDE 0875 part 3 | | | | | | | | | | | |
| | Immunity | EN 50082-2, IEC 801-2, IEC 801-3, IEC 801-4, IEC 801-5, VDE 0160, SEN 361503 | | | | | | | | | | | |

* If shielded cable is to be used, consult Danfoss for cable length.

1) In the range –10 to 0°C, the equipment can start and run; however, the display values and certain operating characteristics will not fulfill the specifications.

3 Phase, 380/400/415 Volt, Units

| | | VLT type | 3575 | 3600 | 3625 | 3650 | 3700 | 3750 | 3800 | |
|---------------------------------------|-------------------------------------|---------------------------------------------------|------------------------------------------------------------------------------|--------|----------|----------|----------|----------|----------|------|
| | Output current | $I_{VLT,N}$ [A] | 105 | 139 | 168 | 205 | 243 | 302 | 368 | |
| | | $I_{VLT,MAX}$ (60 s) [A] | 116 | 153 | 185 | 226 | 267 | 332 | 405 | |
| | Output | $S_{VLT,N}$ [kVA] | 73 | 96 | 116 | 142 | 168 | 209 | 255 | |
| | Typical shaft output | $P_{VLT,N}$ [HP] | 75 | 100 | 125 | 150 | 200 | 250 | 300 | |
| | Max. cable cross-section | [AWG] | 2/0 | 2/0 | 500mcm | 500mcm | 500mcm | 2x250mcm | 2x250mcm | |
| | Max. motor cable length | [feet] | 1000 (unshielded)* | | | | | | | |
| | Output voltage | V_M [%] | 1-100, of AC line voltage | | | | | | | |
| | Output frequency | f_M [Hz] | 0-120 | | | | | | | |
| | Rated motor voltage | $V_{M,N}$ [V] | 380/400/415/440/460/500 | | | | | | | |
| | Rated motor frequency | $f_{M,N}$ [Hz] | 50/60/87/100 | | | | | | | |
| | Thermal protection during operation | | Integrated thermal motor protection (electronic); thermistor to DIN44081 | | | | | | | |
| | Switching on output | | Unlimited (frequent switching may cause cut-out) | | | | | | | |
| | Ramp times | [s] | 0.1-3600 | | | | | | | |
| | | VLT type | 3575 | 3600 | 3625 | 3650 | 3700 | 3750 | 3800 | |
| | Max. input current | $I_{L,N}$ [A] | 103.3 | 138.4 | 167.2 | 201.7 | 241.9 | 293.3 | 366.3 | |
| | | $I_{L,MAX}$ (60S) [A] | 116 | 153 | 185 | 226 | 267 | 332 | 405 | |
| | Max. cable cross-section | [AWG] | 250mcm | 250mcm | 2x250mcm | 2x250mcm | 2x250mcm | 2x250mcm | 2x250mcm | |
| | Max. pre-fuses ¹⁾ | [A] | 150 | 150 | 250 | 250 | 300 | 450 | 500 | |
| | Supply voltage | [V] | 3 x 380/400/415/440/460/500 ±10% | | | | | | | |
| | Supply frequency φ | [Hz] | 50/60 | | | | | | | |
| | Power factor / cos | | 0.9/1.0 | | | | | | | |
| | Efficiency | | 0.96 at 100% load | | | | | | | |
| | Switching on input | times/min. | 1 | | | | | | | |
| | Radio noise, cable borne | | With option: EN55011, class B, group 1, VDE 0875 part 3, curve G | | | | | | | |
| | | | VLT type | 3575 | 3600 | 3625 | 3650 | 3700 | 3750 | 3800 |
| | Weight (lbs) and enclosure type | NEMA 1 (IP21) | | 323 | 323 | 464 | 464 | 484 | 673 | 673 |
| | | NEMA 12 (IP 54) | | 323 | 323 | 464 | 464 | 484 | 673 | 673 |
| Power loss at max. load [W] | Front | | 529 | 713 | 910 | 1091 | 1503 | 1812 | 2209 | |
| | Cooling rib | | 1074 | 1447 | 1847 | 2216 | 3051 | 3679 | 4485 | |
| Vibration test | [g] | 0.7 | | | | | | | | |
| Relative humidity | [%] | VDE 0160 5.2.1.2. | | | | | | | | |
| Ambient temperature | [°C] | | -10 → +40, operation at full load ¹⁾ | | | | | | | |
| | | | -30/25 → +65/70, storage/transport | | | | | | | |
| Adjustable frequency drive protection | | Protection against grounding and short-circuiting | | | | | | | | |
| EMC standards | Emission | | EN 50011, VDE 0875 part 3 | | | | | | | |
| | Immunity | | EN 50082-2, IEC 801-2, IEC 801-3, IEC 801-4, IEC 801-5, VDE 0160, SEN 361503 | | | | | | | |

* If shielded cable is to be used, consult Danfoss for cable length.

1) In the range -10 to 0°C, the equipment can start and run; however, the display values and certain operating characteristics will not fulfill the specifications.

3 Phase, 440/460/500 Volt, Units

| | | VLT type | 3575 | 3600 | 3625 | 3650 | 3700 | 3750 | 3800 | |
|----------|---------------------------------------|------------------------------------------------------------------------------|--------------------------------------------------------------------------|--------|----------|----------|----------|----------|----------|--|
| | Output current | $I_{VLT,N}$ [A] | 96 | 124 | 156 | 180 | 240 | 302 | 361 | |
| | | $I_{VLT,MAX}$ (60 s) [A] | 106 | 136 | 172 | 198 | 264 | 332 | 397 | |
| | Output | $S_{VLT,N}$ [kVA] | 83 | 107 | 135 | 156 | 208 | 262 | 313 | |
| | Typical shaft output | $P_{VLT,N}$ [HP] | 75 | 100 | 125 | 150 | 200 | 250 | 300 | |
| | Max. cable cross-section | [AWG] | 2/0 | 2/0 | 500mcm | 500mcm | 500mcm | 2x250mcm | 2x250mcm | |
| | Max. motor cable length | [feet] | 1000 (unshielded)* | | | | | | | |
| | Output voltage | V_M [%] | 1-100, of AC line voltage | | | | | | | |
| | Output frequency | f_M [Hz] | 0-120 | | | | | | | |
| | Rated motor voltage | $V_{M,N}$ [V] | 380/400/415/440/460/500 | | | | | | | |
| | Rated motor frequency | $f_{M,N}$ [Hz] | 50/60/87/100 | | | | | | | |
| | Thermal protection during operation | | Integrated thermal motor protection (electronic); thermistor to DIN44081 | | | | | | | |
| | Switching on output | | Unlimited (frequent switching may cause cut-out) | | | | | | | |
| | Ramp times | [s] | 0.1-3600 | | | | | | | |
| | | VLT type | 3575 | 3600 | 3625 | 3650 | 3700 | 3750 | 3800 | |
| | Max. input current | $I_{L,N}$ [A] | 94.4 | 123.4 | 155.3 | 177.1 | 238.9 | 307.6 | 359.3 | |
| | | $I_{L,MAX}$ (60S) [A] | 106 | 136 | 172 | 198 | 264 | 332 | 397 | |
| | Max. cable cross-section | [AWG] | 250mcm | 250mcm | 2x250mcm | 2x250mcm | 2x250mcm | 2x250mcm | 2x250mcm | |
| | Max. pre-fuses ¹⁾ | [A] | 150 | 150 | 250 | 250 | 300 | 450 | 500 | |
| | Supply voltage | [V] | 3 x 380/400/415/440/460/500 ±10% | | | | | | | |
| | Supply frequency φ | [Hz] | 50/60 | | | | | | | |
| | Power factor / cos | | 0.9/1.0 | | | | | | | |
| | Efficiency | | 0.96 at 100% load | | | | | | | |
| | Switching on input | times/min. | 1 | | | | | | | |
| | Radio noise, cable borne | | With option: EN55011, class B, group 1, VDE 0875 part 3, curve G | | | | | | | |
| | | VLT type | 3575 | 3600 | 3625 | 3650 | 3700 | 3750 | 3800 | |
| | Weight (lbs) and enclosure type | NEMA 1 (IP21) | 323 | 323 | 464 | 464 | 484 | 673 | 673 | |
| | | NEMA 12 (IP 54) | 323 | 323 | 464 | 464 | 484 | 673 | 673 | |
| | Power loss at max. load [W] | Front | 529 | 713 | 910 | 1091 | 1503 | 1812 | 2209 | |
| | | Cooling rib | 1074 | 1447 | 1847 | 2216 | 3051 | 3679 | 4485 | |
| | Vibration test | [g] | 0.7 | | | | | | | |
| | Relative humidity | [%] | VDE 0160 5.2.1.2. | | | | | | | |
| | Ambient temperature | [°C] | -10 → +40, operation at full load ¹⁾ | | | | | | | |
| | | | -30/25 → +65/70, storage/transport | | | | | | | |
| | Adjustable frequency drive protection | | Protection against grounding and short-circuiting | | | | | | | |
| | EMC standards | Emission | EN 50011, VDE 0875 part 3 | | | | | | | |
| Immunity | | EN 50082-2, IEC 801-2, IEC 801-3, IEC 801-4, IEC 801-5, VDE 0160, SEN 361503 | | | | | | | | |

* If shielded cable is to be used, consult Danfoss for cable length.

1) In the range -10 to 0°C, the equipment can start and run; however, the display values and certain operating characteristics will not fulfill the specifications.

VLT 3502 Dimensions

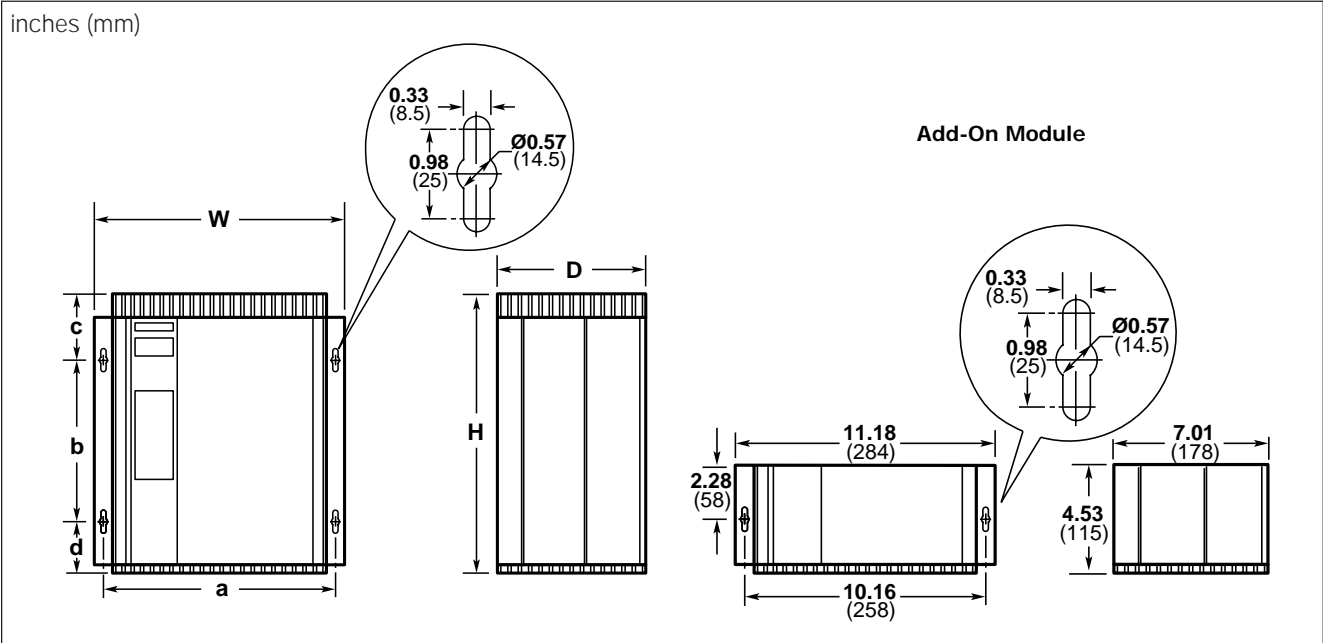

| Type | Input VAC | Overall Dimensions | | | Mounting Dimensions | | | |
|----------|-----------|--------------------|-------------|------------|---------------------|-------------|------------|-----------|
| | | H | W | D | a | b | c | d |
| Chassis* | 230 | | | | | | | |
| Chassis* | 380 | 11.81 (300) | 11.18 (284) | 7.01 (178) | 10.16 (258) | 7.48 (190) | 2.17 (55) | 2.17 (55) |
| Chassis* | 460 | | | | | | | |
| NEMA 1* | 230 | 15.35 (390) | | | | | 4.53 (115) | |
| NEMA 1* | 380 | 14.17 (360) | 11.18 (284) | 7.01 (178) | 10.16 (258) | 7.48 (190) | 3.35 (85) | 3.35 (85) |
| NEMA 1* | 460 | | | | | | | |
| NEMA 12 | 230 | | | | | | | |
| NEMA 12 | 380 | 20.87 (530) | 11.18 (284) | 7.01 (178) | 10.16 (258) | 12.99 (330) | 4.53 (115) | 3.35 (85) |
| NEMA 12 | 460 | | | | | | | |

* Additional dimensions for Fan Option:
 Chassis (all voltages) 2.36 (60) to H; 2.36 (60) to c
 NEMA 1 (all voltages) 1.18 (30) to H; 1.18 (30) to c

VLT 3504 Dimensions

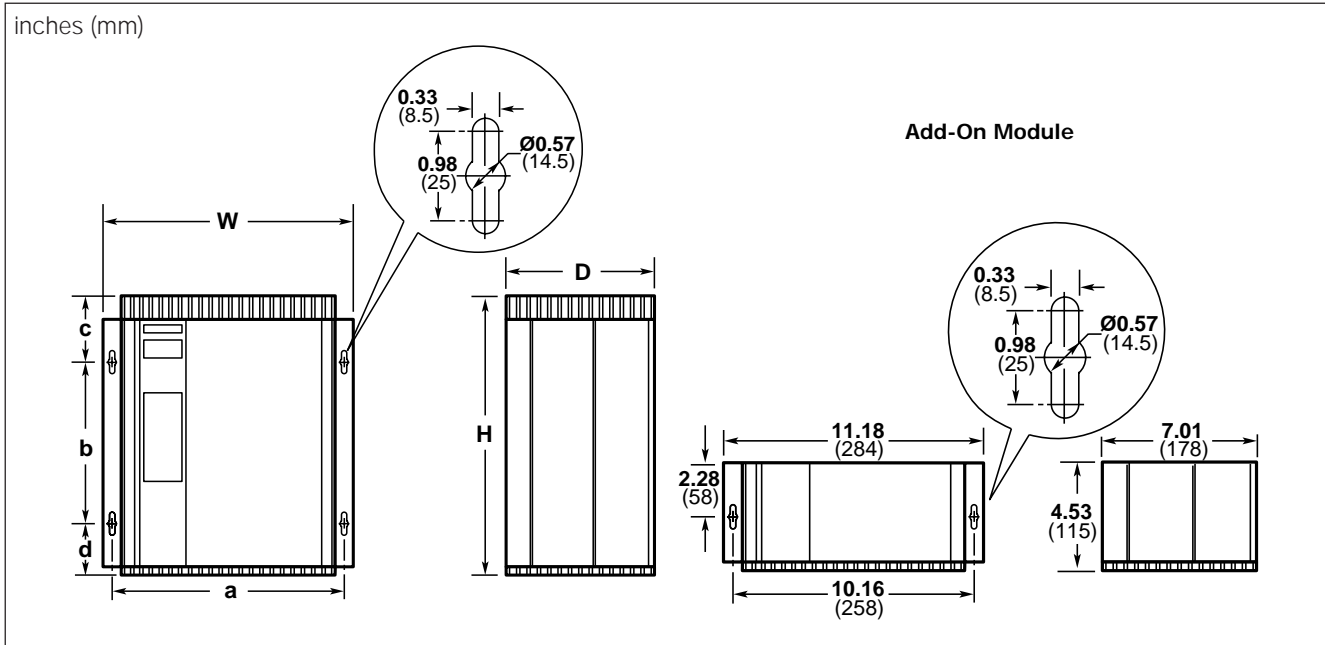

| Type | Input VAC | Overall Dimensions | | | Mounting Dimensions | | | |
|----------|-----------|--------------------|-------------|------------|---------------------|-------------|------------|-----------|
| | | H | W | D | a | b | c | d |
| Chassis* | 230 | | | | | | | |
| Chassis* | 380 | 11.81 (300) | 11.18 (284) | 7.01 (178) | 10.16 (258) | 7.48 (190) | 2.17 (55) | 2.17 (55) |
| Chassis* | 460 | | | | | | | |
| NEMA 1* | 230 | | | | | | | |
| NEMA 1* | 380 | 15.35 (390) | 11.18 (284) | 7.01 (178) | 10.16 (258) | 7.48 (190) | 4.53 (115) | 3.35 (85) |
| NEMA 1* | 460 | 14.17 (360) | 11.18 (284) | 7.01 (178) | 10.16 (258) | 7.48 (190) | 3.35 (85) | 3.35 (85) |
| NEMA 12 | 230 | | | | | | | |
| NEMA 12 | 380 | 20.87 (530) | 11.18 (284) | 7.01 (178) | 10.16 (258) | 12.99 (330) | 4.53 (115) | 3.35 (85) |
| NEMA 12 | 460 | | | | | | | |

* Additional dimensions for Fan Option:
 Chassis (all voltages) 2.36 (60) to **H**; 2.36 (60) to **c**
 NEMA 1 (all voltages) 1.18 (30) to **H**; 1.18 (30) to **c**

VLT 3505 Dimensions

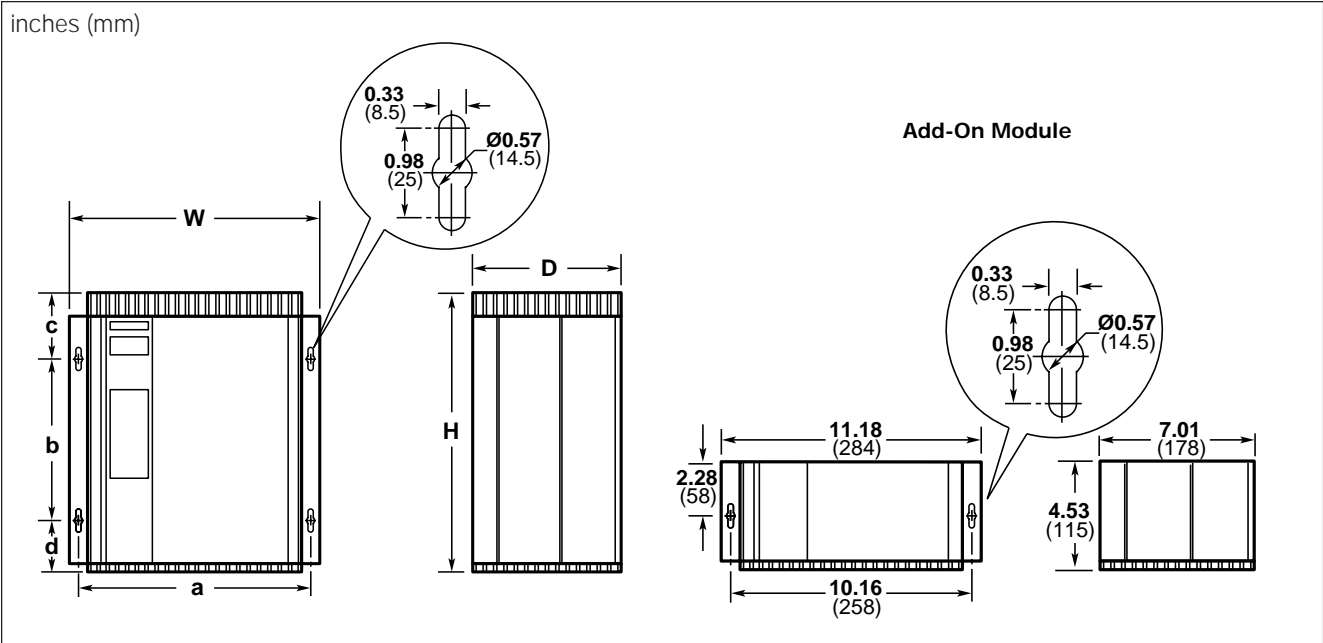

| Type | Input VAC | Overall Dimensions | | | Mounting Dimensions | | | |
|----------|-----------|--------------------|-------------|------------|---------------------|-------------|------------|-----------|
| | | H | W | D | a | b | c | d |
| Chassis* | 380 | 11.81 (300) | 11.18 (284) | 7.01 (178) | 10.16 (258) | 7.48 (190) | 2.17 (55) | 2.17 (55) |
| NEMA 1* | 380 | 15.35 (390) | 11.18 (284) | 7.01 (178) | 10.16 (258) | 7.48 (190) | 4.53 (115) | 3.35 (85) |
| NEMA 12 | 380 | 20.87 (530) | 11.18 (284) | 7.01 (178) | 10.16 (258) | 12.99 (330) | 4.53 (115) | 3.35 (85) |

* Additional dimensions for Fan Option:
 Chassis 2.36 (60) to H; 2.36 (60) to c
 NEMA 1 1.18 (30) to H; 1.18 (30) to c

VLT 3506 Dimensions

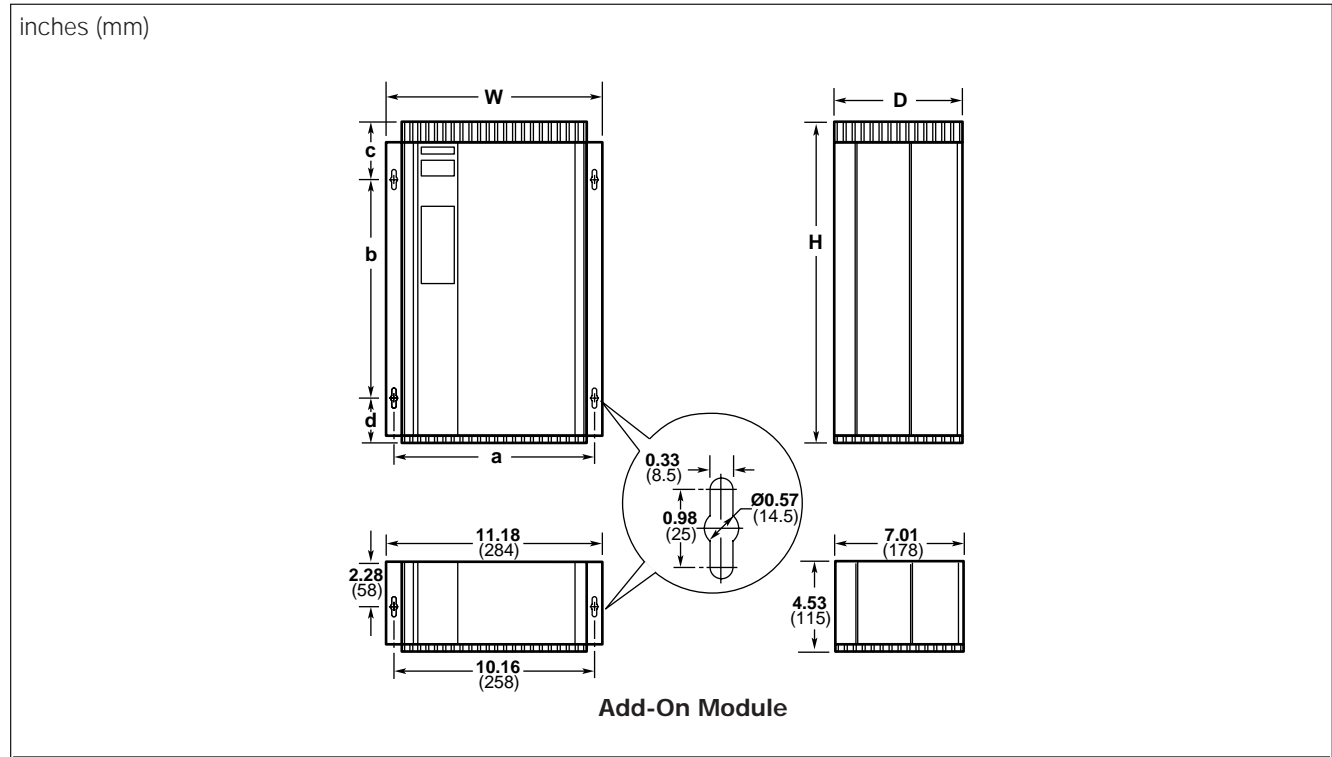

| Type | Input VAC | Overall Dimensions | | | Mounting Dimensions | | | |
|----------|-----------|--------------------|-------------|------------|---------------------|-------------|------------|-----------|
| | | H | W | D | a | b | c | d |
| Chassis* | 460 | 17.32 (440) | 11.18 (284) | 7.01 (178) | 10.16 (258) | 12.99 (330) | 2.17 (55) | 2.17 (55) |
| NEMA 1* | 460 | 19.69 (500) | 11.18 (284) | 7.01 (178) | 10.16 (258) | 12.99 (330) | 3.35 (85) | 3.35 (85) |
| NEMA 12 | 460 | 20.87 (530) | 11.18 (284) | 7.01 (178) | 10.16 (258) | 12.99 (330) | 4.53 (115) | 3.35 (85) |

* Additional dimensions for Fan Option: Chassis 2.36 (60) to H; 2.36 (60) to c; NEMA 1 1.18 (30) to H; 1.18 (30) to c.

VLT 3508 Dimensions

inches (mm)

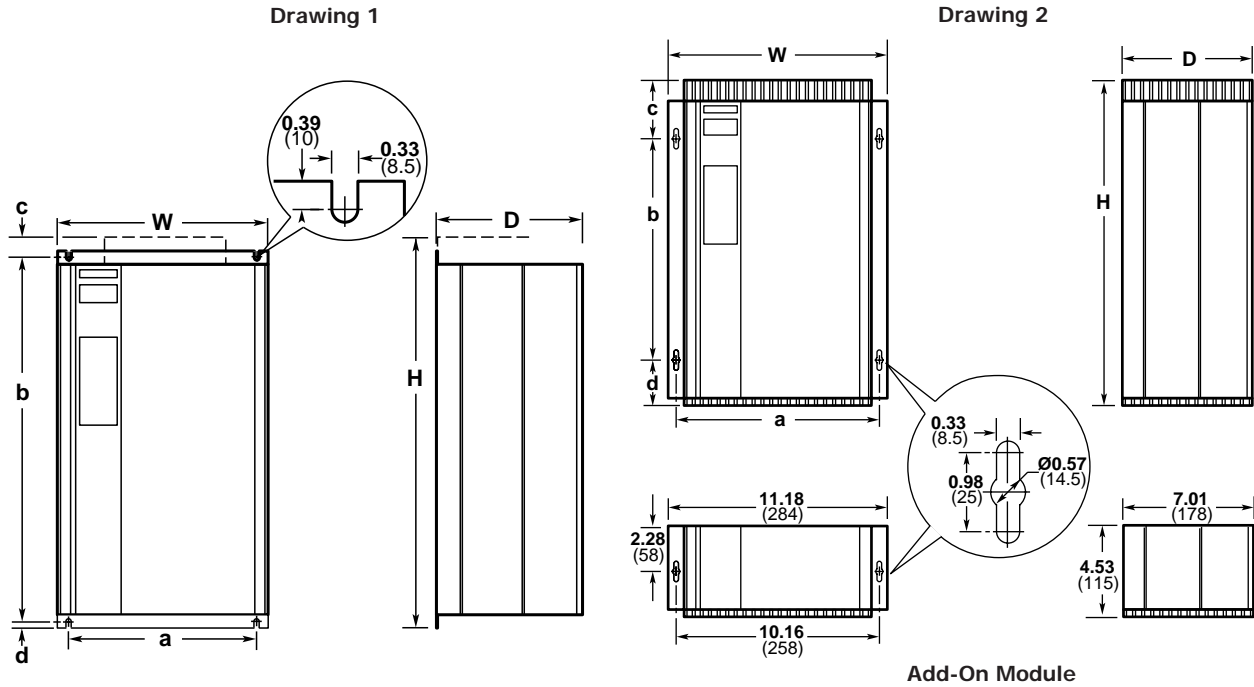
Drawing 1

| Type | Input VAC | Overall Dimensions | | | Mounting Dimensions | | | |
|----------------|-----------|----------------------------|------------|-------------|---------------------|-------------|------------------------|-----------|
| | | H | W | D | a | b | c | d |
| Chassis NEMA 1 | 230 | 25.98 (660) 26.77 (680) | 9.53 (242) | 10.24 (260) | 7.87 (200) | 25.20 (640) | 0.39 (10) 1.18 (30) | 0.39 (10) |

Drawing 2

| Type | Input VAC | Overall Dimensions | | | Mounting Dimensions | | | |
|-------------------------|-------------------|----------------------------|----------------------------|---------------------------|----------------------------|----------------------------|--------------------------|------------------------|
| | | H | W | D | a | b | c | d |
| Chassis Chassis | 380 460 | 19.69 (500) | 11.18 (284) | 7.01 (178) | 10.16 (258) | 12.99 (330) | 4.53 (115) | 2.17 (55) |
| NEMA 1 NEMA 1 | 380 460 | 20.87 (530) | 11.18 (284) | 7.01 (178) | 10.16 (258) | 12.99 (330) | 4.53 (115) | 3.35 (85) |
| NEMA 12 NEMA 12 NEMA 12 | 230 380 460 | 31.89 (810) 20.87 (530) | 13.78 (350) 11.18 (284) | 11.02 (280) 7.01 (178) | 12.83 (326) 10.16 (258) | 22.05 (560) 12.99 (330) | 7.09 (180) 4.53 (115) | 2.76 (70) 3.35 (85) |

* 230 VAC dimensions do not change with options.

VLT 3511 Dimensions

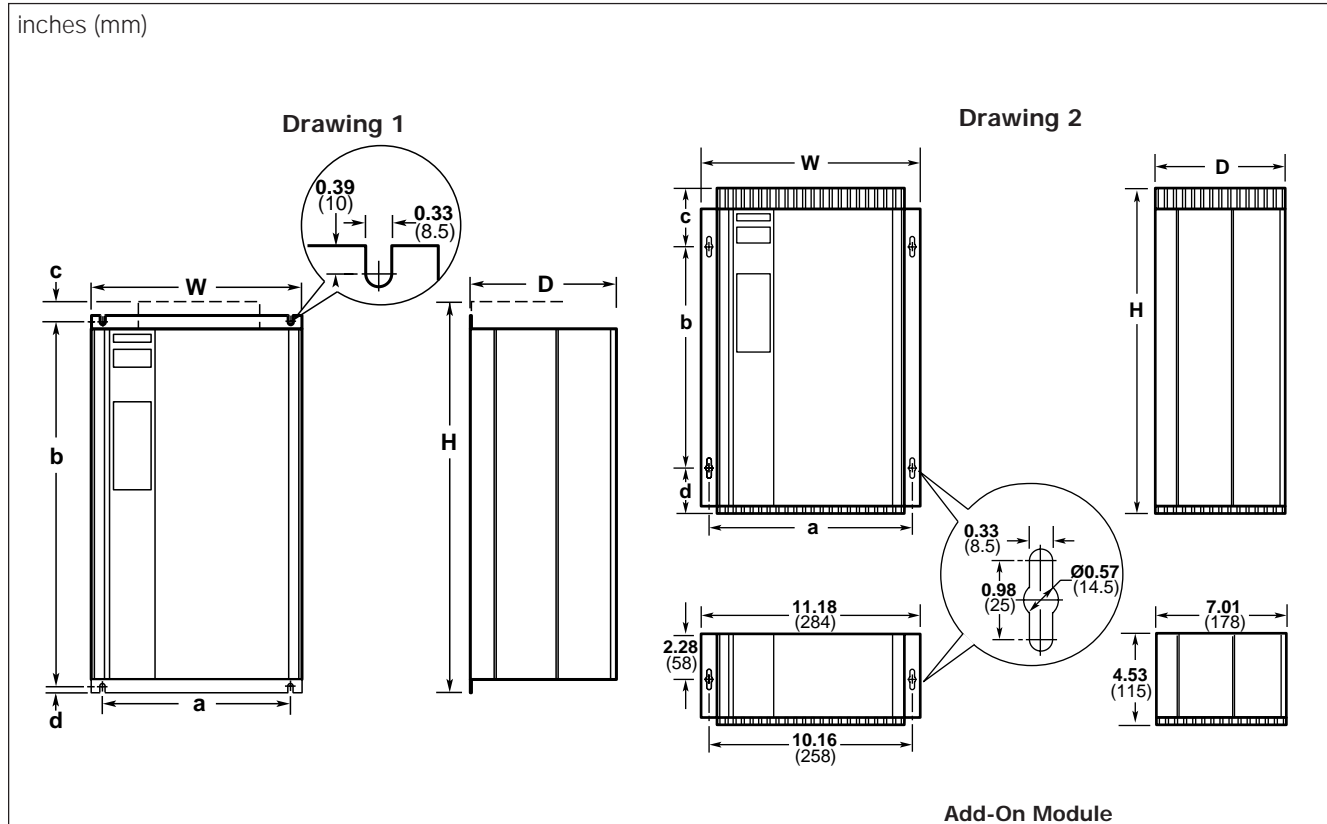

Drawing 1

| Type | Input VAC | Overall Dimensions | | | Mounting Dimensions | | | |
|---------|-----------|--------------------|------------|-------------|---------------------|-------------|-----------|-----------|
| | | H | W | D | a | b | c | d |
| Chassis | 230 | 25.98 (660) | 9.53 (242) | 10.24 (260) | 7.87 (200) | 25.20 (640) | 0.39 (10) | 0.39 (10) |
| NEMA 1 | 230 | 26.77 (680) | 9.53 (242) | 10.24 (260) | 7.87 (200) | 25.20 (640) | 1.18 (30) | 0.39 (10) |

Drawing 2

| Type | Input VAC | Overall Dimensions | | | Mounting Dimensions | | | |
|---------|-----------|--------------------|-------------|-------------|---------------------|-------------|------------|-----------|
| | | H | W | D | a | b | c | d |
| Chassis | 380 | 19.69 (500) | 11.18 (284) | 7.01 (178) | 10.16 (258) | 12.99 (330) | 4.53 (115) | 2.17 (55) |
| Chassis | 460 | | | | | 4.53 (115) | | |
| NEMA 1 | 380 | 20.87 (530) | 11.18 (284) | 7.01 (178) | 10.16 (258) | 12.99 (330) | 4.53 (115) | 3.35 (85) |
| NEMA 1 | 460 | | | | | | | |
| NEMA 12 | 230 | 31.89 (810) | 13.78 (350) | 11.02 (280) | 12.83 (326) | 22.05 (560) | 7.09 (180) | 2.76 (70) |
| NEMA 12 | 380 | 20.87 (530) | 11.18 (284) | 7.01 (178) | 10.16 (258) | 12.99 (330) | 4.53 (115) | 3.35 (85) |
| NEMA 12 | 460 | | | | | | | |

VLT 3516 Dimensions

inches (mm)

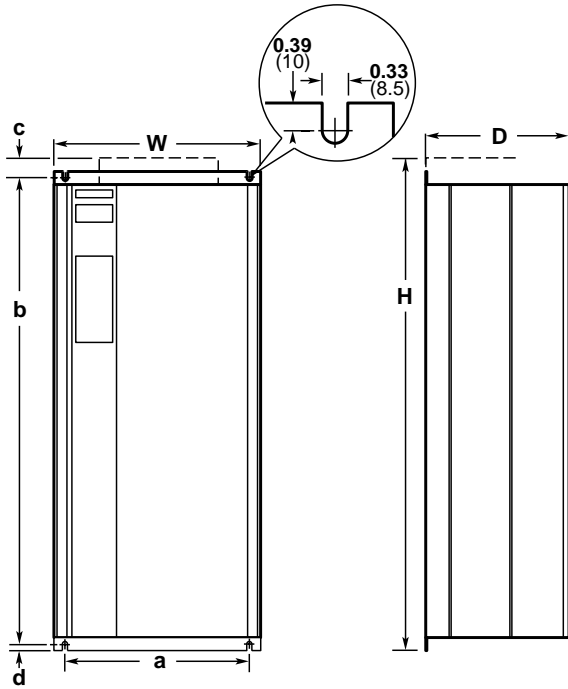

Drawing 1

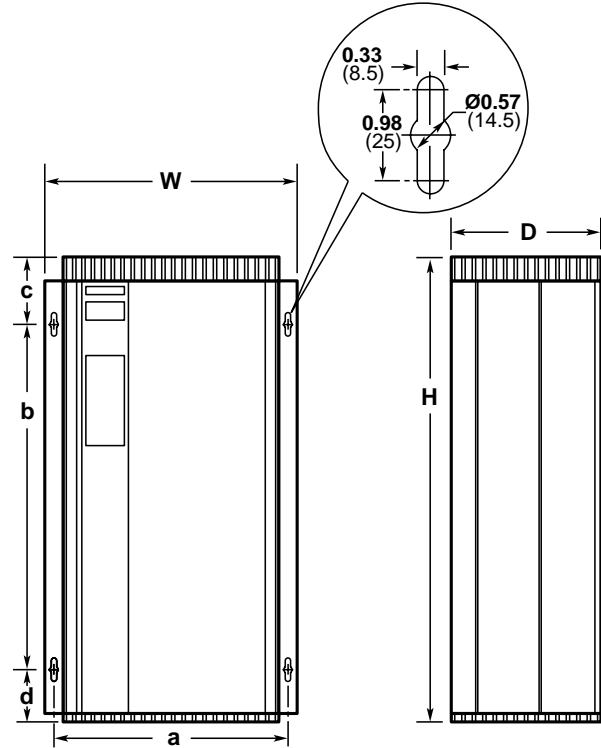

Drawing 2

Drawing 1

| Type | Input VAC | Overall Dimensions | | | Mounting Dimensions | | | |
|---------|-----------|--------------------|------------|-------------|---------------------|-------------|-----------|-----------|
| | | H | W | D | a | b | c | d |
| Chassis | 230 | 30.71 (780) | | | | | | |
| Chassis | 380 | 25.98 (660) | 9.53 (242) | 10.24 (260) | 7.87 (200) | 29.92 (760) | 0.39 (10) | 0.39 (10) |
| Chassis | 460 | | | | | 25.20 (640) | | |
| NEMA 1 | 230 | 31.50 (800) | | | | | | |
| NEMA 1 | 380 | 26.77 (680) | 9.53 (242) | 10.24 (260) | 7.87 (200) | 29.92 (760) | 1.18 (30) | 0.39 (10) |
| NEMA 1 | 460 | | | | | 25.20 (640) | | |

Drawing 2

| Type | Input VAC | Overall Dimensions | | | Mounting Dimensions | | | |
|---------|-----------|--------------------|-------------|-------------|---------------------|-------------|------------|-----------|
| | | H | W | D | a | b | c | d |
| NEMA 12 | 230 | | | | | | | |
| NEMA 12 | 380 | 31.89 (810) | 13.78 (350) | 11.02 (280) | 12.83 (326) | 22.05 (560) | 7.09 (180) | 2.76 (70) |
| NEMA 12 | 460 | | | | | | | |

VLT 3522 Dimensions

inches (mm)

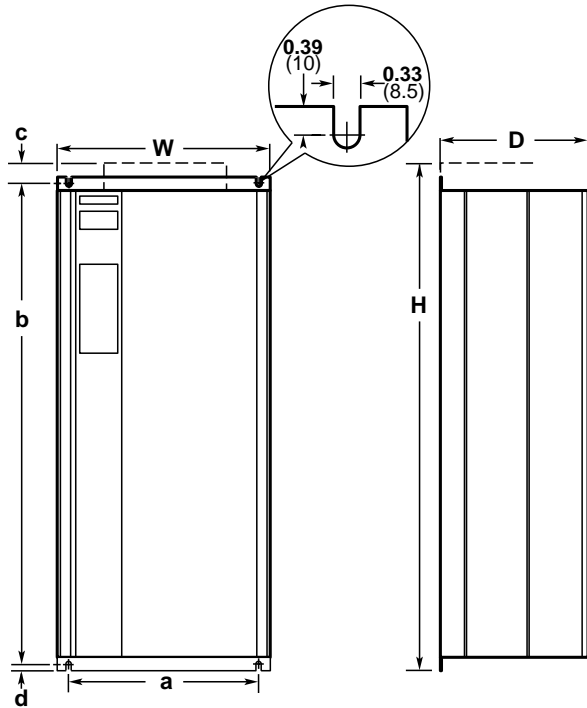

Drawing 1

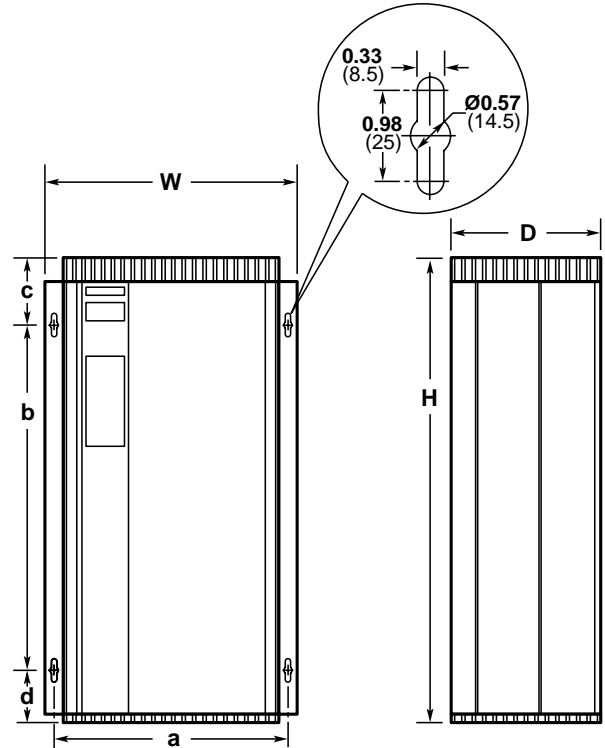

Drawing 2

Drawing 1

| Type | Input VAC | Overall Dimensions | | | Mounting Dimensions | | | |
|---------|-----------|--------------------|-------------|-------------|---------------------|-------------|-----------|-----------|
| | | H | W | D | a | b | c | d |
| Chassis | 230 | 37.40 (950) | 12.09 (307) | 11.65 (296) | 10.63 (270) | 36.61 (930) | | |
| Chassis | 380 | 25.98 (660) | 9.53 (242) | 10.24 (260) | 7.87 (200) | 25.20 (640) | 0.39 (10) | 0.39 (10) |
| Chassis | 460 | | | | | | | |
| NEMA 1 | 230 | 38.39 (975) | 12.09 (307) | 11.65 (296) | 10.63 (270) | 36.61 (930) | 1.38 (35) | |
| NEMA 1 | 380 | 26.77 (680) | 9.53 (242) | 10.24 (260) | 7.87 (200) | 25.20 (640) | 1.18 (30) | 0.39 (10) |
| NEMA 1 | 460 | | | | | | | |

Drawing 2

| Type | Input VAC | Overall Dimensions | | | Mounting Dimensions | | | |
|---------|-----------|--------------------|-------------|-------------|---------------------|-------------|------------|-----------|
| | | H | W | D | a | b | c | d |
| NEMA 12 | 230 | 37.01 (940) | 15.67 (398) | | 14.72 (374) | 27.17 (690) | | |
| NEMA 12 | 380 | 31.89 (810) | 13.78 (350) | 11.02 (280) | 12.83 (326) | 22.05 (560) | 7.09 (180) | 2.76 (70) |
| NEMA 12 | 460 | | | | | | | |

VLT 3532 Dimensions

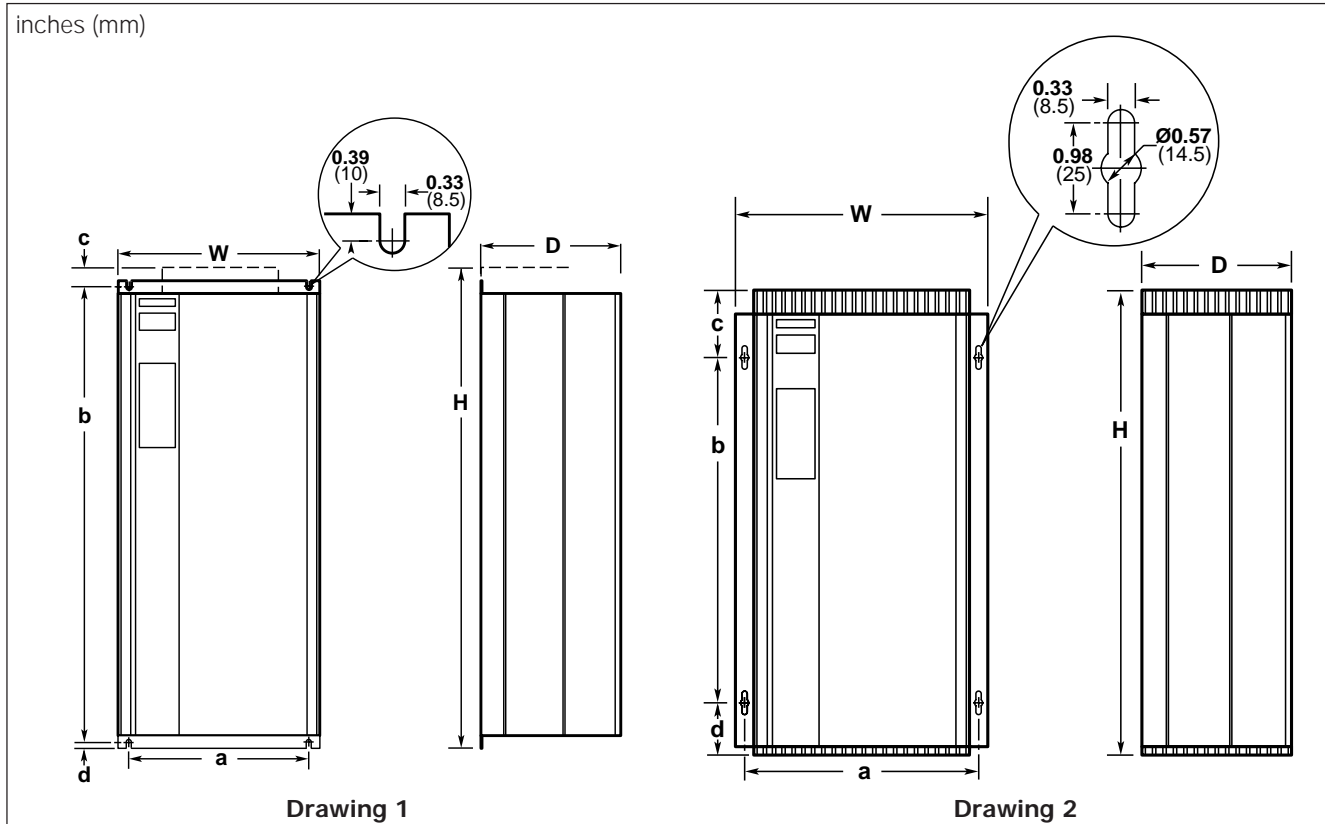

Drawing 1

| Type | Input VAC | Overall Dimensions | | | Mounting Dimensions | | | |
|---------|-----------|--------------------|-------------|-------------|---------------------|-------------|-----------|-----------|
| | | H | W | D | a | b | c | d |
| Chassis | 230 | 37.40 (950) | 12.09 (307) | 11.65 (296) | 10.63 (270) | 36.61 (930) | | |
| Chassis | 380 | 30.71 (780) | 9.53 (242) | 10.24 (260) | 7.87 (200) | 29.92 (760) | 0.39 (10) | 0.39 (10) |
| Chassis | 460 | | | | | | | |
| NEMA 1 | 230 | 38.89 (975) | 12.09 (307) | 11.65 (296) | 10.63 (270) | 36.61 (930) | 1.38 (35) | |
| NEMA 1 | 380 | 31.50 (800) | 9.53 (242) | 10.24 (260) | 7.87 (200) | 29.92 (760) | 1.18 (30) | 0.39 (10) |
| NEMA 1 | 460 | | | | | | | |

Drawing 2

| Type | Input VAC | Overall Dimensions | | | Mounting Dimensions | | | |
|---------|-----------|--------------------|-------------|-------------|---------------------|-------------|------------|-----------|
| | | H | W | D | a | b | c | d |
| NEMA 12 | 230 | 37.01 (940) | 15.67 (398) | | 14.72 (374) | 27.17 (690) | | |
| NEMA 12 | 380 | 31.89 (810) | 13.78 (350) | 11.02 (280) | 12.83 (326) | 22.05 (560) | 7.09 (180) | 2.76 (70) |
| NEMA 12 | 460 | | | | | | | |

Dimensions

VLT 3542, 3552, 3562, 380 and 460 V

(for 230 V units refer to page 20)

inches (mm)

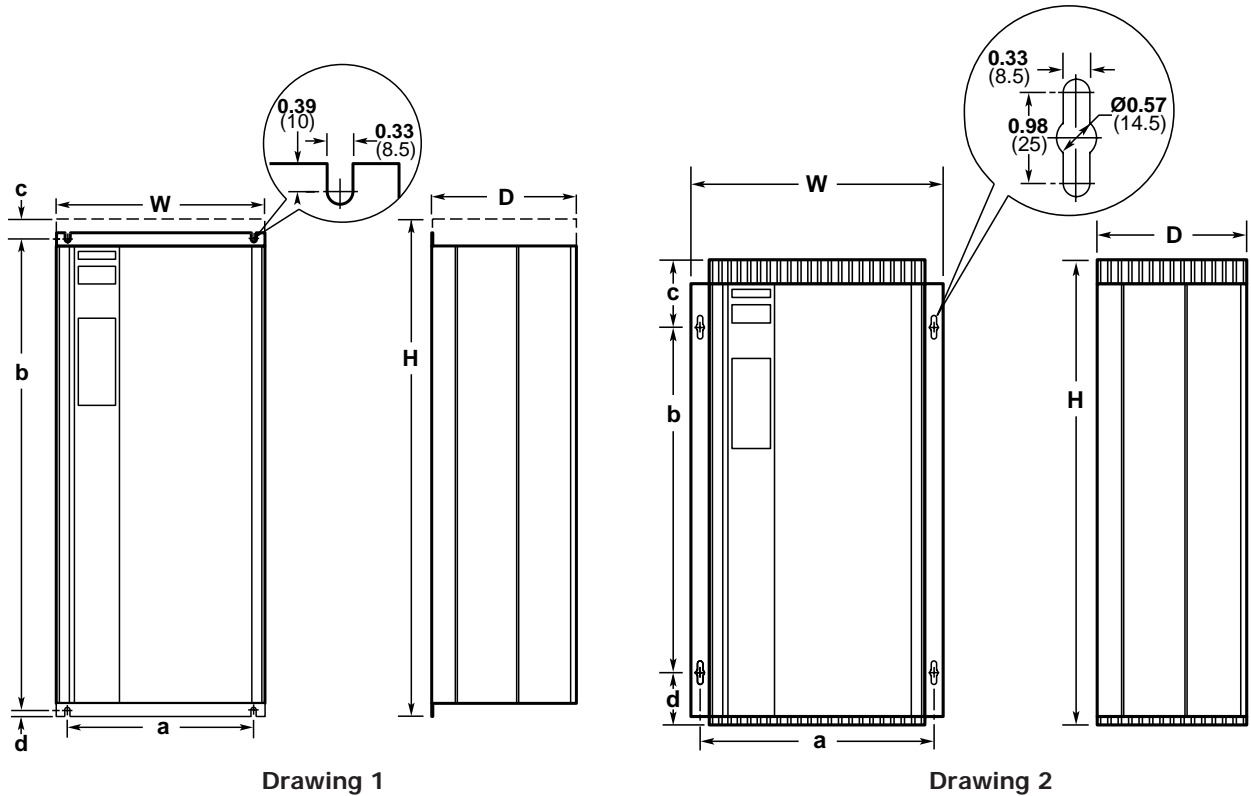

Drawing 1

Drawing 2

Drawing 1

| Type | Input VAC | Overall Dimensions | | | Mounting Dimensions | | | |
|---------|-----------|--------------------|-------------|-------------|---------------------|-------------|-----------|-----------|
| | | H | W | D | a | b | c | d |
| Chassis | 380 | 37.40 (950) | 12.09 (307) | 11.65 (296) | 10.63 (270) | 36.61 (930) | 0.39 (10) | 0.39 (10) |
| Chassis | 460 | | | | | | | |
| NEMA 1 | 230 | Refer to page 20 | | | | | | |
| NEMA 1 | 380 | 38.39 (975) | 12.09 (307) | 11.65 (296) | 10.63 (270) | 36.61 (930) | 1.38 (35) | 0.39 (10) |
| NEMA 1 | 460 | | | | | | | |

Drawing 2

| Type | Input VAC | Overall Dimensions | | | Mounting Dimensions | | | |
|---------|-----------|--------------------|-------------|-------------|---------------------|-------------|------------|-----------|
| | | H | W | D | a | b | c | d |
| NEMA 12 | 230 | Refer to page 20 | | | | | | |
| NEMA 12 | 380 | 37.01 (940) | 15.67 (398) | 11.02 (280) | 14.72 (374) | 27.17 (690) | 7.09 (180) | 2.76 (70) |
| NEMA 12 | 460 | | | | | | | |

Dimensions

VLT 3542, 3552, 3562, 230 V

VLT 3575, 3600, 380 and 460 V

inches (mm)

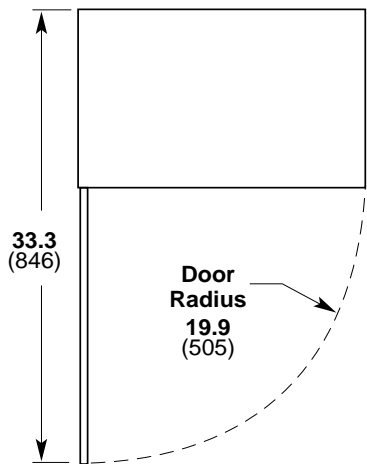
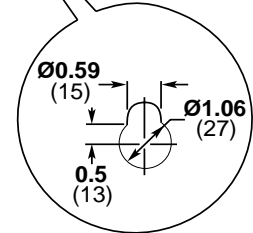
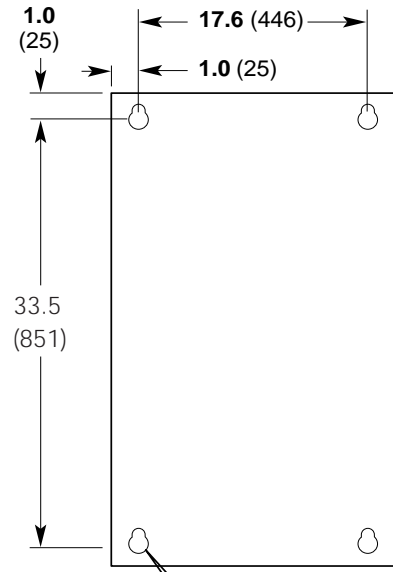
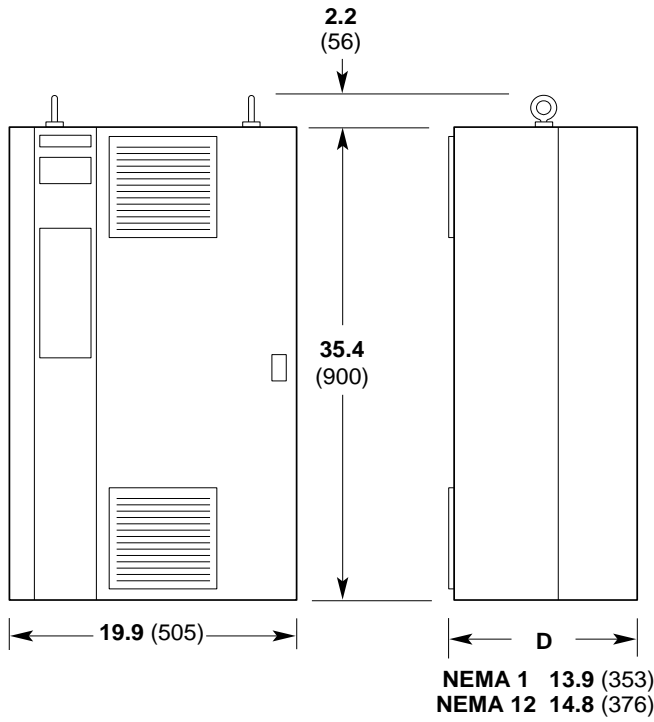

Dimensions

VLT 3625, 3650, 3700, 380 and 460 V

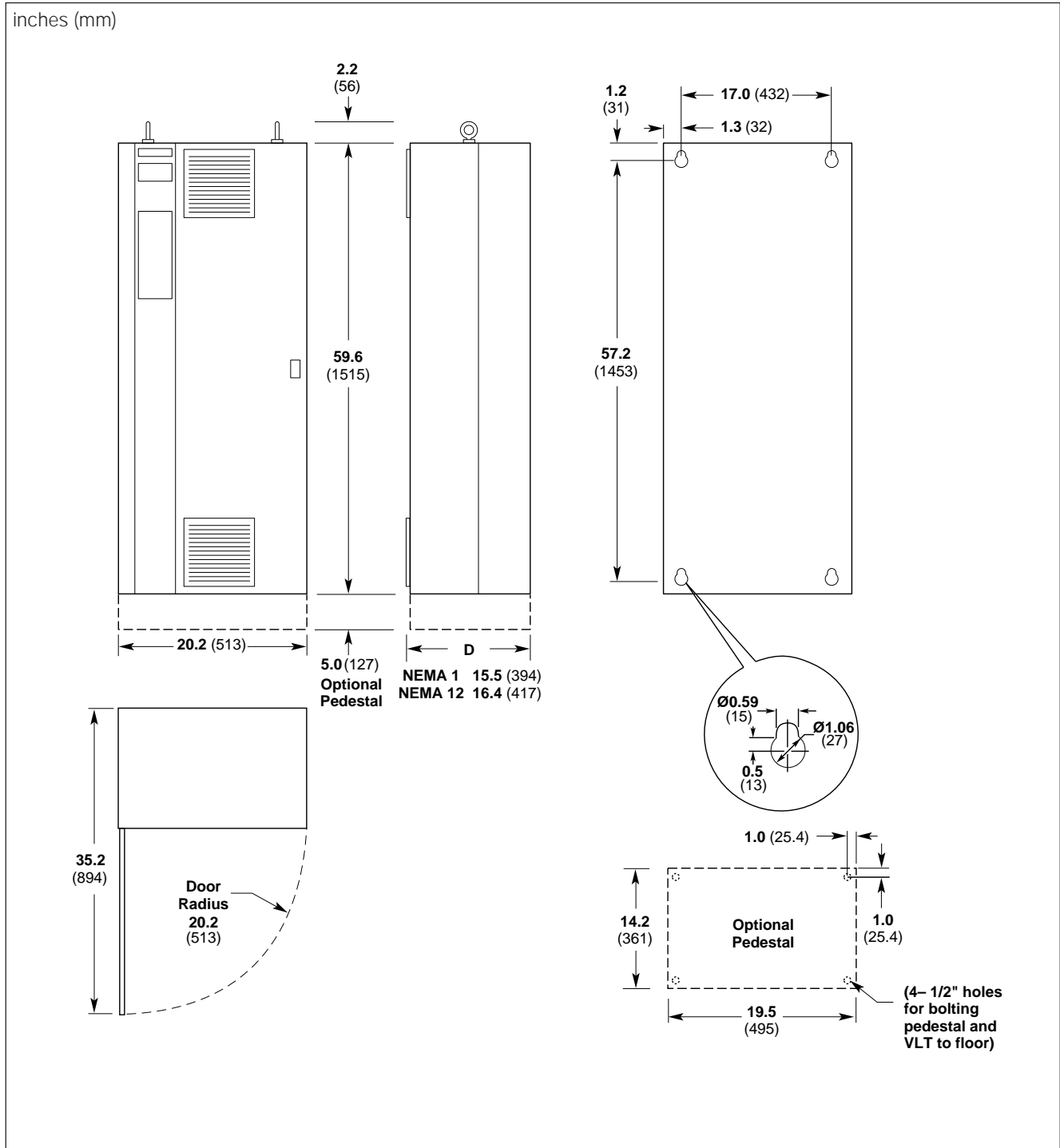

Dimensions

VLT 3750, 3800, 380 and 460 V

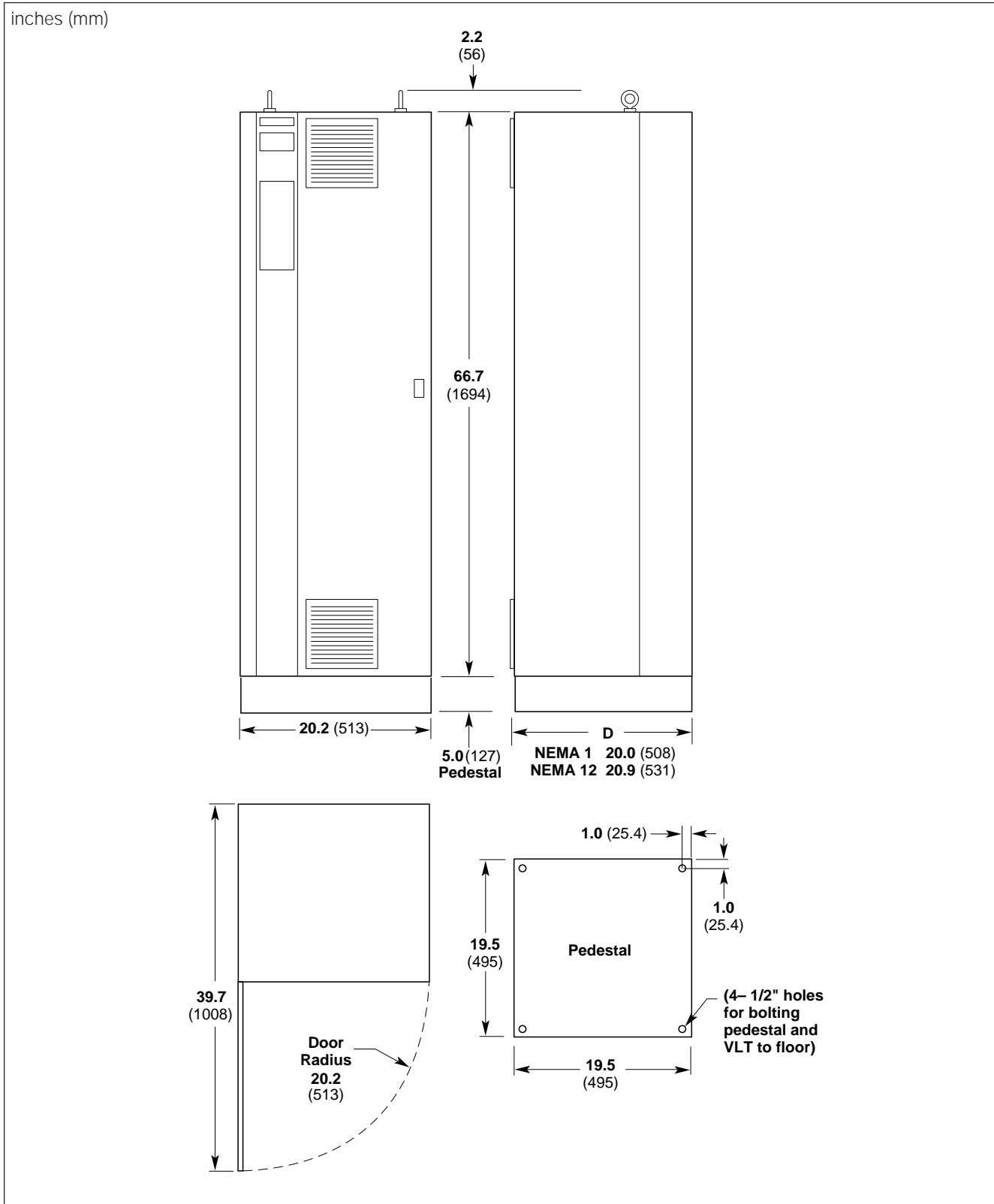

General

The specific installation instructions may vary depending upon the model of VLT Series 3500 being installed. When this occurs, the model will be identified by a “VLT Type 3XXX” number. This number can be found on the red nameplate on the outside of the left side of the drive enclosure, or the outside of the right side of a drive with an auxiliary enclosure.

The drive must always be attached firmly to the wall or the floor before further installation work is carried out, so as to ensure that no injury or damage occurs.

VLT Series 3500 is cooled by means of air circulation. Consequently, the air needs to be able to move freely above and below the drive.

VLT Type 3502-3562

This series must be installed on a solid surface to ensure that the air flow is in contact with the heatsink all the way from the bottom of the drive. Drives with mounting holes in the side flanges can be installed flange-to-flange. Drives without side flanges but with mounting holes at top and bottom can be installed without any free space on the sides.

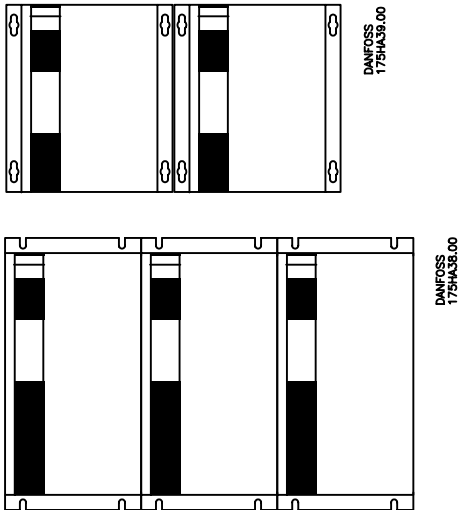

VLT Series 3500 can be installed with the flanges side by side.

VLT Type 3575-3700 and 3542-3562 208/230 V

VLT Type 3575-3700, 380/500 V and VLT Type 3542-3562, 208/230 V are supplied with a mounting bracket placed at the back of the drive. The mounting bracket also serves as an air duct for the heat sinks. The bracket must be mounted on the drive before drive operation. The bracket does not need to be removed for installation purposes. However, it is possible to remove it temporarily by loosening the bolts from the inside of the drive.

If the bracket is removed for installation, it must be reinstalled to prevent overheating. The key slots in the mounting bracket make it possible to fasten the attachment bolts to the wall or in the panel before hanging the unit.

VLT Type 3575-3600, 380/500 V and VLT Type 3542-3562, 208/230 V are intended for wall mount only.

VLT Type 3625-3700 is supplied for wall mount as standard, but can be mounted on an optional mounting base.

VLT 3750-3800 is intended for floor mount only, using the mounting base supplied.

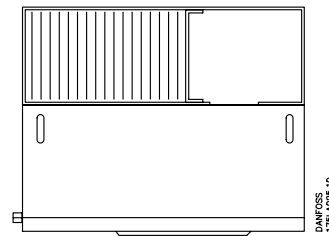

Drawing shows drive seen from above.

Base for VLT Type 3625-3800

As an option, a base for floor installation can be supplied for VLT Type 3625-3700. VLT 3750-3800 is intended for floor installation only. The base must be fastened to the floor by means of four bolts before installing the drive. Unscrew the front plate of the base to fasten the drive through the four top holes in the base. Also refer to the section on cooling for further information.

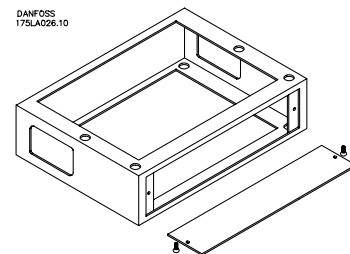

Mounting base

The drawing shows the base and its dimensions.

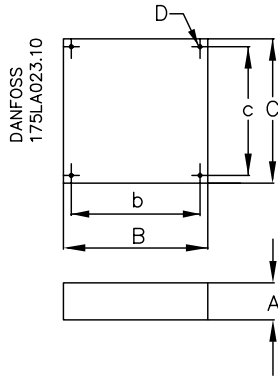

| VLT Type | 3625-3700 | 3750-3800 |
|----------|-----------|-----------|
| A | 5.00 | 5.00 |
| B | 19.49 | 19.49 |
| C | 14.21 | 19.49 |
| D | 4 x 0.5 | 4 x 0.5 |
| b | 17.52 | 17.52 |
| c | 12.20 | 17.52 |

All dimensions are in inches

Base seen from the side:

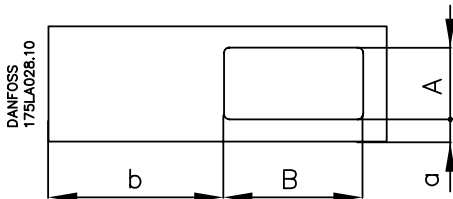

Base

| VLT type | 3625-3700 | 3750-3800 |
|----------|-----------|-----------|
| A | 2.99 | 3.94 |
| B | 5.94 | 6.93 |
| a | 0.91 | 0.39 |
| b | 7.52 | 11.30 |

All dimensions are in inches

Base for mounting NEMA 12 cabinet with RFI module

| VLT type | 3625-3700 | 3750-3800 |
|----------|-----------|-----------|
| A | 3.11 | 4.02 |
| B | 6.02 | 7.01 |
| a | 0.91 | 0.39 |
| b | 7.52 | 11.30 |

All dimensions are in inches

Hinged Door on VLT Type 3575-3800

The door on the VLT Type 3575-3800 is hinged on the left-hand side.

The table below gives the door radius and the necessary distance from the mounting surface for the door to be able to open freely:

| VLT type | 3575* | 3600 | 3625 | 3650 | 3700 | 3750 | 3800 |
|----------|-------|-------|-------|-------|-------|-------|-------|
| C | 33.31 | 33.31 | 35.20 | 35.20 | 35.20 | 39.69 | 39.69 |
| R | 19.88 | 19.88 | 20.20 | 20.20 | 20.20 | 20.20 | 20.20 |

All dimensions are in inches

* Dimensions for VLT Type 3575 also apply to VLT 3542-3562, 208/230 volt units.

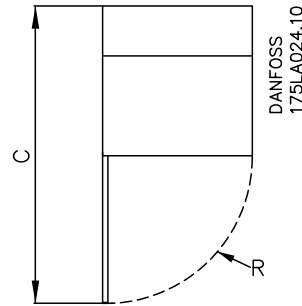

Cooling

For a free flow of cooling air, space is required both above and below the drive. The minimum space required depends on the drive model and the enclosure type. All dimensions are in inches.

For VLT Type 3502-3562, 460 V and 3532-3532, 230 V, the following applies:

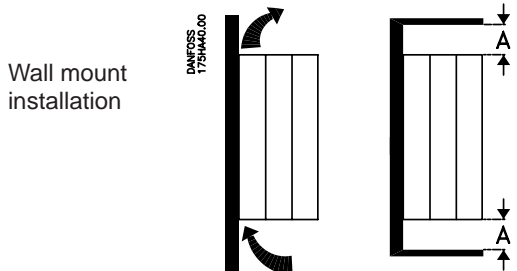

Floor Stand Kit Mounting

If a drive designed for wall mounting is mounted to a floor stand kit or is not mounted directly to a wall, a solid panel at least as large as the back surface of the drive must be mounted flush to the mounting holes of the drive. This is necessary to create an air chamber for the cooling air to pass over the fins on the heatsink.

| Drive Only | A | Drive w/Auxiliary Enclosure | A |
|------------|-----|-----------------------------|-----|
| Chassis | 6.0 | VLT Type 3502- 3504 230 V | 3.9 |
| NEMA 1 | 6.0 | VLT Type 3508-3532 280 V | 7.9 |
| NEMA 12 | 6.0 | VLT Type 3502- 3511 460 V | 3.9 |
| | | VLT Type 3516-3562 460 V | 7.9 |

For VLT Type 3575-3700; and VLT type 3542-3562, 230 V which are wall-mounted, the following applies:

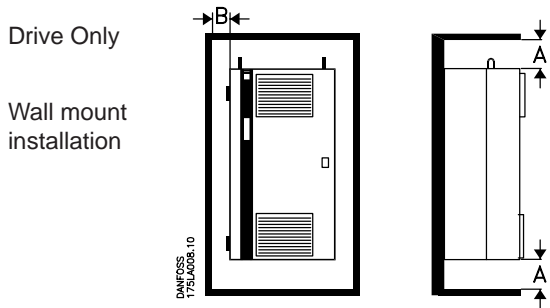

A drive without an auxiliary enclosure can be installed without any free space to the sides; however, the door must be able to open fully (Distance B) for service access.

| VLT Type | A | B |
|-----------|------|-----|
| 3542-3562 | 6.75 | 1.0 |
| 3575-3600 | 6.75 | 1.0 |
| 3625-3700 | 9.00 | 1.0 |

For VLT Type 3625-3800 without auxiliary enclosures which are floor mounted, the following applies:

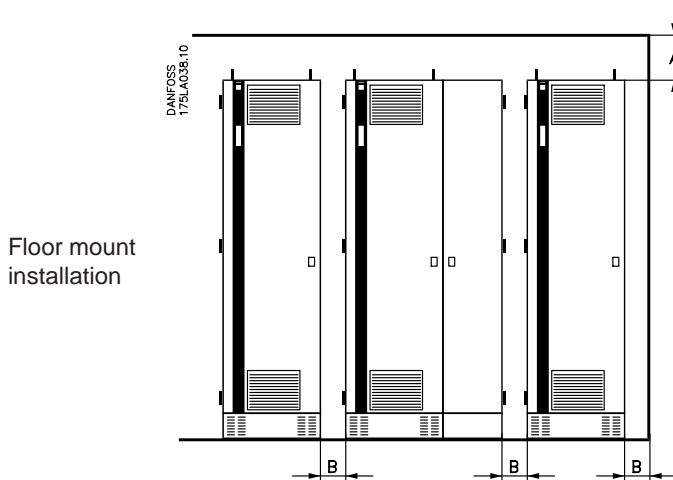

| VLT Type | A | B |
|-----------|------|------|
| 3625-3700 | 9.00 | 5.12 |
| 3750-3800 | 9.00 | 5.12 |

The distance between drives must be at least 5.12" for the air inlet in the base. VLT Type 3575-3800 has a fan in the front door which cools the internal components. A distance which allows free opening of the door is sufficient in front of the drive.

For VLT Type 3575-3800 and VLT Type 3542-3562, 230 V with auxiliary enclosures, the following applies:

The distance between drives must be at least 5.12" for the air inlet in floor mounted units. VLT Type 3575-3800 has a fan in the front door which cools the internal components. A distance which allows free opening of the door is sufficient in front of the drive.

| VLT Type | Top | Bottom | Left | Right |
|------------------------------|------|--------|------|-------|
| 3542-3562, 230 V, wall mount | 6.7 | 6.7 | * | * |
| 3575-3600, wall mount | 6.7 | 6.7 | * | * |
| 3625-3700, wall mount | 9.1 | 9.1 | * | * |
| 3625-3700, floor mount | 9.1 | 5.1 | 5.1 | * |
| 3750-3800, floor mount | 10.3 | 5.1 | 5.1 | * |

* Door swing must be accommodated on both sides.

Input Power Wiring

VLT Type 3502-3504, 208/230 volt; VLT Type 3502-3511, 380 volt; and VLT Type 3502-3508, 460 volt with NEMA 1 or NEMA 12 enclosures have a plastic bottom cover with marked provision for conduit entry.

To meet UL requirements, a bonding plate must be in place in the plastic bottom cover. The plate must be grounded to the chassis, and the conduit grounded to the plate.

If the grounding plate is not factory installed, it must be installed in the drives that have a plastic bottom panel to ensure proper grounding of the conduit. Connect the ground wire from the bonding plate to the ground tab marked GND. This tab is located near the AC line terminal strip. Mount the bottom cover on the control unit.

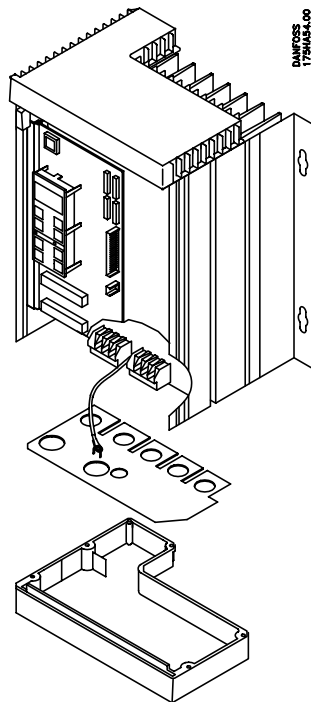

The conduit entries provide strain relief for the wires in drives mounted in NEMA 1 or NEMA 12 enclosures. With the chassis mount drives, the power and control wires need to be have strain relief supplied by the installer. Do not rely upon the terminal blocks to provide strain relief.

VLT Type 3516-3562, 460 volt, and VLT Type 3508-3532, 208/230 volt have a metal bottom with cutouts for conduit entry.

VLT Type 3575-3800, 460 volt and VLT Type 3542-3562, 208/230 volt drives have a wiring access plate on both the bottom and the side of the drive. It is recommended that the larger, bottom wiring access plate be used for conduit entry. Remove the plate before drilling for the power and control wires. Drill all required holes before running any of the wires through the plate. Do not make any of the holes any larger than required to fasten to conduit. Reinstall the plate after drilling and wiring the drive. The plate must be in place to provide protection to the drive and provide proper air flow for cooling.

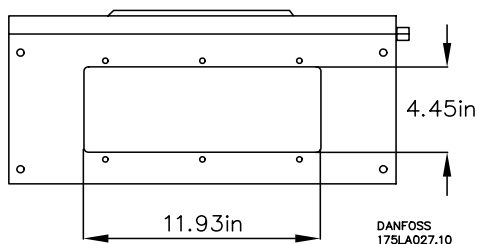

Wiring access plate on bottom of enclosure

⚠WARNING

The enclosure for these larger drives and for the auxiliary enclosures is made of steel. To avoid getting steel chips in the electronics, do not drill any holes until after the unit has been installed in a vertical position. Remove the conduit plate before drilling.

Shielded Wires

Wires to control signals should be shielded to reduce radio noise interference.

When radio noise (RFI or EMI) is a concern, shielded cable should be used between the drive and the motor.

If unshielded control wires are used, control inputs are subject to signal disturbances. Such disturbances may affect drive operation. Extreme noise levels may disturb the microprocessor of the control card. The drive may fault and “EXCEPT” will appear in the display.

The shield of the control wires must be grounded at the cable clamp at the bottom of the drive, but the shield must continue with the cable all the way up to the control card. The shield is not to be connected to any of the terminals at the control card .

For safety reasons, the insulation around the shield should only be removed where it is connected to the cable clamp. The insulation should be left on the shield between the clamp and the terminals.

Generally speaking, all conductors coming from a shielded control cable must be as short as possible. Long conductor ends attract noise. The shield must be connected to the chassis by means of the cable clamp. Long pigtailed on the shield reduce the effectiveness of the shield.

Danfoss VLT® and CE Marking

Danfoss CE marks our VLT® Adjustable Frequency Drives (AFD) according to the Electro Magnetic Compatibility (EMC) Directive 89/336/EEC and Low-Voltage Directive 73/23/EEC.

When the installation specification is followed and shielded motor cables are used per instruction manuals provided with the drive, we guarantee the AFD complies with the EMC Directive 89/336/EEC. Please consult the RFI Filter Product Manual and EMC Installation Guidelines (175R5187).

Upon request we will issue a declaration of conformity to the EMC and low-voltage directives. A manufacturer's declaration for the Machinery Directive 89/392/EEC is also available.

⚠ DANGER

The drive voltage is dangerous when connected to the AC line and up to 14 minutes after the unit has been disconnected. Electrical installation is only to be carried out by a qualified electrician. Incorrect mounting of the motor or the drive may result in damage to the equipment, serious personal injury or death. The instructions in this manual must be complied with, together with national and local safety regulations.

NOTE
 It is the responsibility of the user or the electrician to ensure that the drive is properly grounded in accordance with applicable national and local standards.

Input Fuses

For VLT Type 3502-3562 drives, external input fuses must be installed in the power supply for the drive, if not specified as a drive option. The maximum size of the input fuses is shown below. For VLT Type 3575 - 3800 460 volt, and VLT 3542 - 3562 208/230 volt drives, the input fuses are included in the basic drive. All fuses must be Bussman JJN for 200 - 230 volt drives, JJS for 380 - 415 and 440 - 500 volt drives or exact equivalent.

| Input Voltage | VLT Type | Max. Fuse Rating |
|---------------|----------|------------------|
| 200 - 230 V | 3502 | 20 A |
| | 3504 | 25 A |
| | 3508 | 40 A |
| | 3511 | 50 A |
| | 3516 | 60 A |
| | 3522 | 80 A |
| | 3532 | 125 A |
| | 3542 | 150 A |
| | 3552 | 150 A |
| | 3562 | 150 A |

| Input Voltage | VLT Type | Max. Fuse Rating |
|---------------|----------|------------------|
| 380 - 415 V | 3502 | 16 A |
| | 3504 | 16 A |
| | 3505 | 16 A |
| | 3508 | 25 A |
| | 3511 | 25 A |
| | 3516 | 50 A |
| | 3522 | 63 A |
| | 3532 | 63 A |
| | 3542 | 80 A |
| | 3552 | 100 A |
| | 3562 | 125 A |

| Input Voltage | Max. Drive Output Current | Max. Fuse Rating |
|---------------|---------------------------|------------------|
| 440 - 500 V | 3502 | 10 A |
| | 3504 | 20 A |
| | 3506 | 25 A |
| | 3508 | 25 A |
| | 3516 | 30 A |
| | 3522 | 40 A |
| | 3532 | 50 A |
| | 3542 | 60 A |
| | 3552 | 100 A |
| | 3562 | 125 A |

NOTE: It is the responsibility of the user or person installing the drive to provide proper grounding and branch circuit protection for incoming power and motor overload according to the National Electrical Code (NEC) and local codes.

The Electronic Thermal Relay (ETR) in UL listed VLTs provides Class 20 motor overload protection in accordance with NEC in single motor applications, when parameter 315 is set for "TRIP", parameter 311 is set of "0", and parameter 107 is set for rated motor (nameplate) current.

Power and Motor Terminals

The terminals for both the three phase AC line input and the motor output are located in the lower portion of the enclosure of the drive.

The electronic thermal relay (ETR) cannot be used for more than one motor running at a time. ETR has been UL approved for operating individual motors only when parameter 315 has been set to TRIP, parameter 311 has been set to 0 sec., and parameter 107 has been programmed to match the rated motor (nameplate) current.

The AC line supply and the motor must be connected as shown on the following pages. Refer to the appropriate figure for your VLT type.

NOTE: Shielded motor cable is optional in most U.S. applications. Refer to CE Marking section in this manual.

The shield on the motor wire, if used, should be connected to earth ground at both the drive and the motor.

Typical Line and Motor Connection

VLT 3502, 3504, 230V units

VLT 3502, 3504, 3505, 3508, 380V units

VLT 3502, 3504, 3506, 3508, 460V units

VLT 3508, 3511, 230V units

VLT 3511, 3516, 3522, 3532, 380V units

VLT 3511, 3516, 3522, 3532, 460V units

VLT 3516, 3522, 3532, 230V units

VLT 3542, 3552, 3562, 380V units

VLT 3542, 3552, 3562, 460V units

Typical Line and Motor Connection

VLT 3542, 3552, 3562, 230V units

VLT 3575, 3600, 380V units

VLT 3575, 3600, 460V units

VLT 3625, 3650, 3700, 380V units

VLT 3625, 3650, 3700, 460V units

VLT 3750, 3800, 380V units

VLT 3750, 3800, 460V units

Motor Connections

All types of three-phase asynchronous standard motors can be used with the VLT Series 3500.

Wire the motor for the proper voltage as shown on the motor nameplate. Wire the motor to terminals U, V, and W (96, 97 and 98) on the drive.

Direction of Rotation

The factory setting gives clockwise rotation when the output of the VLT Series 3500 has been connected as follows:

- Terminal 96: connected to U
- Terminal 97: connected to V
- Terminal 98: connected to W

The direction of rotation can be changed by swapping any two motor wires.

Parallel Connection of Motors

VLT Series 3500 can control several motors connected in parallel. If the motor speeds are to be different, motors of different rated speeds must be used. The speed of all of the motors will change simultaneously. The ratio between the rated motor speeds will be maintained over the whole range.

The total current consumption by the motors must not exceed the maximum rated output current of the drive.

If the motor sizes vary considerably, the speeds may be different when run slowly. This is because small motors have a relatively high resistance in the stator and therefore require a higher voltage at start and at low speeds than larger motors. This should not be a concern in HVAC applications.

In systems with parallel motor operation, the electronic thermal relay cannot be used as motor protection of an individual motor. This is because the output current must be programmed to match the overall motor current. Consequently, additional motor protection is required, such as individual thermal relays or thermistors in every motor.

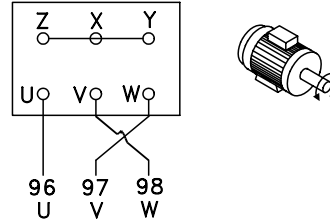
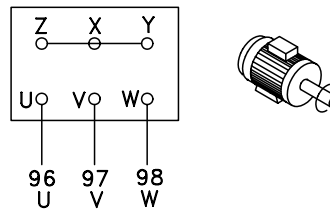

DANFOSS
175H A222.10

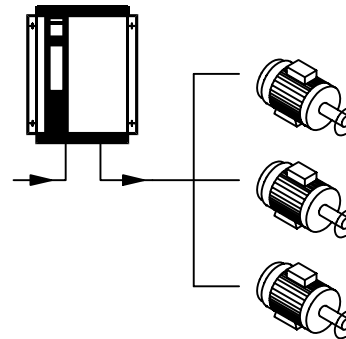

DANFOSS
175H A222.10

Terminal Block Locations

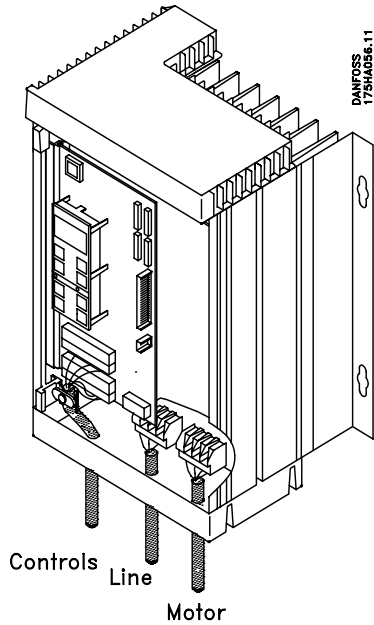

VLT Type

3502 - 3511 Series, 380 V
 3502 - 3504 Series, 208/230 V
 3502 - 3508 Series, 460 V

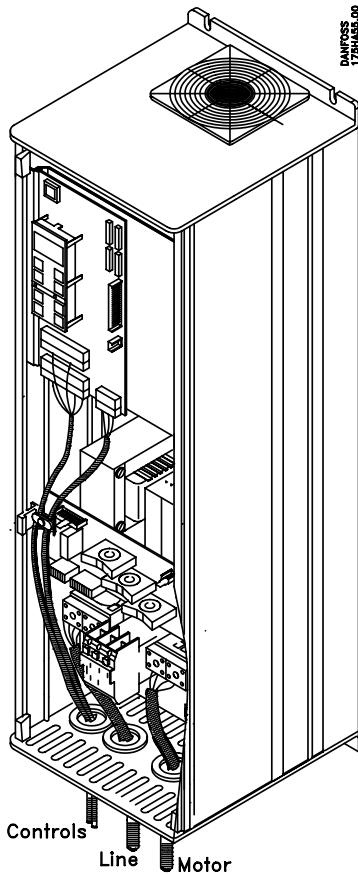

VLT Type

3511 - 3562 Series, 380 - 460 V
 3508 - 3532 Series, 208/230 V

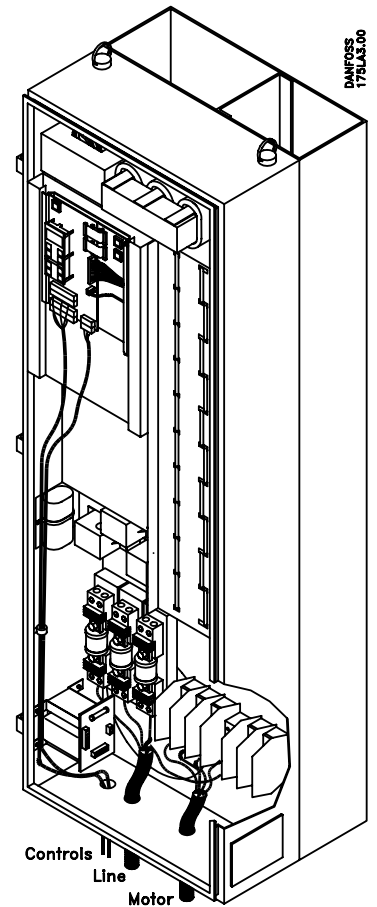

VLT Type

3575 - 3800 Series, 380 - 460 V
 3542 - 3562 Series, 208/230 V

Programmable Terminal Functions

| Terminal | Parameter | Function | | | | | | | |
|----------|-----------|----------------------|----------------|-------------------------|--------------------------|--------------------|--------------------|--------------|---------------|
| 16 | 400 | Reset | Stop | Freeze Reference | Setup Select | Thermistor | External HAND | | |
| 17 | 401 | Reset | Stop | Freeze Reference | ↓ | Pulse 100Hz | Pulse 1 kHz | Pulse 10 kHz | External AUTO |
| 18 | 402 | Start | Latched Start | No Operation | External AUTO | | | | |
| 19 | 403 | Reverse | Start Reverse | No Operation | External HAND | Latched Start Hand | | | |
| 27 | 404 | Coast to Stop | Quick Stop | DC Braking | Reset and Coast | Stop | | | |
| 29 | 405 | Jog | Jog Freeze | Freeze Reference | Digital Ref. Select | Ramp Select | Latched Start Hand | | |
| 32 | 406 | Preset Speed Sel | Increase Speed | Setup Select | Ext. Setup Select | | | | |
| 33 | ↓ | ↓ | Decrease Speed | ↓ | ↓ | | | | |

Bold Type indicates default settings stored in the drive's read-only factory setup. Because of special application requirements, these may not have been used in the active set up that was shipped with the drive.

Control Card Terminals

The drawing at the right shows the control card terminals on the VLT Series 3500 drive, and the parameters that control them. A description of the control signals and terminals is below.

Terminal 39:

Common for analog/digital outputs.

Terminals 42 and 45:

Programmable analog or digital outputs for indicating output frequency, input reference, output current and output torque. The analog signal is 0 to 20 mA or 4 to 20 mA at a maximum of 470 W. The digital indication can be of operational status, or alarm or warning. The digital signal is 24 V DC at a minimum 600 W. See parameters 407 and 408.

Terminal 50:

This provides the supply voltage to the potentiometer and the thermistor. It is 10 V DC, 17 mA max.

Terminal 53:

Connect a DC analog voltage reference input to this terminal. Voltage range is 0 to 10 V DC, $R_i = 10 \text{ kW}$. See parameter 412.

Terminal 55:

Common for analog reference inputs.

Terminal 60:

Connect a DC analog current reference input to this terminal. Current range is 0 or 4 to 20 mA, $R_i = 188 \text{ W}$. See parameter 413.

Terminal 61:

Ground connection, when switch 04 is closed, this connects to chassis ground. When switch 04 is open, an RC filter is connected between this terminal and ground.

Terminals 68 and 69:

Serial bus communication. Parameter group 5 is used to set up this interface.

Terminal 12:

This provides the supply voltage to digital inputs. The voltage is 24 V DC, maximum 140 mA.

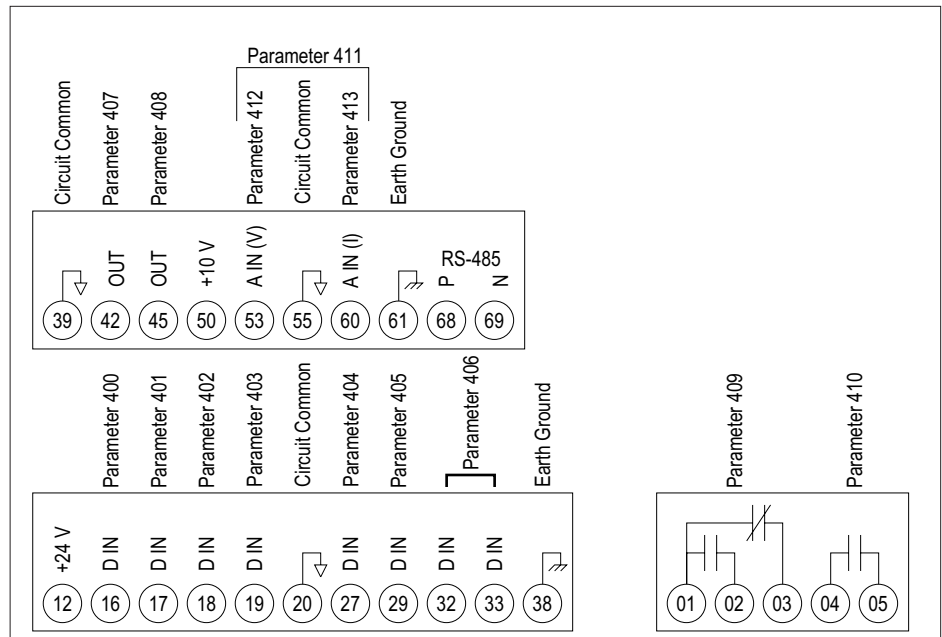

Terminals 16 and 33:

These are the digital input terminals. The input must be 0 to 24 V, $R_i = 2 \text{ kohm}$. $< 5V = \text{logical "0"}$, $> 10 \text{ V} = \text{logical "1"}$. See parameters 400 through 406.

Terminal 20:

Common for digital inputs.

Terminal 38:

Ground connection can be used to connect the shield on control wires in units with no cable clamps for the shield.

Terminals 01 and 03:

Connections for Form C relay output. Maximum 240 V AC, 2 A. Minimum 24 V DC, 10 mA or 24 V AC, 100 mA. See parameter 409.

Terminals 04 and 05:

Connections for Form A relay output. Maximum 240 V AC, 2 A. Minimum 24 V DC, 10 mA or 24 V AC, 100 mA. See parameter 410.

NOTE:

If a thermistor is used for motor protection, it must be wired from terminal 50 to terminal 16. See parameter 400.

Electrical Noise

In general, electrical noise can be divided into two forms: wire-borne noise (EMI) and radiating noise (RFI).

As shown in the sketch below, the capacitance of the motor wires combined with a high dV/dt from the motor voltage generates noise.

The use of shielded motor cables increases the noise current (I_1) as indicated in the figure below. This is because shielded wires have a greater capacitance than unshielded wires. If the noise current is not filtered, there will be more noise on the AC line in the radio noise range, below approximately 5 MHz. Since the noise current (I_1) is taken back to the unit through the shield (I_3), only a small electromagnetic field will in principle be generated from the shielded motor wires. See the figure below.

The shield reduces the radiating noise, but increases the low-frequency noise on the AC line. With an EMI filter, the noise level on the AC line will be reduced to about the same level for shielded and unshielded wires alike.

The motor wiring shield must be connected in the enclosure of the drive as well as at the motor. The best way of doing this is by using shield brackets to avoid "pigtail" shield ends. Even short "pigtails" increase the shield's impedance at higher frequencies, which reduces the shield's effect and increases the noise current.

If a shielded cable is used for serial communication and signal interface, the shield must be connected at both ends. In certain situations, however, it will be necessary to break the shield to avoid current loops.

In cases where the shield is to be connected to a mounting plate, the mounting plate must be made of metal, because the shield currents are to be taken back to the unit. It is also important to ensure good, electric contact from the mounting plate through the mounting screws to the chassis of the VLT Series 3500.

It is generally easier and less complicated to use unshielded motor wires than shielded cables. If unshielded wires are used, the RFI will be greater. Since the strength of the radiated signal decreases with distance from the signal source, radiated noise is generally not a problem.

In order to reduce the noise level from the total system (drive + installation) to the greatest possible extent, it is important to make the motor wiring as short as possible.

Incoming power and control wiring should never be run in the same conduit or raceway as motor wiring.

Installation of Units with Optional EMI Filter Module

If an optional EMI filter module is supplied, it is normally mounted below the drive with its own mounting plate. When mounting the drive and EMI filter, it is important to ground the filter mounting plate through its mounting bolts. Because the aluminium enclosure of the drive and EMI filter module is anodized and electrically insulating, serrated washers must be used to penetrate the anodization, or the anodized surface must be removed. The wiring must be done as shown in the figure below. Also refer to EMI filter manual for further information.

Shielded Wiring**Serial Communication**

The wires for serial communication must be shielded. The shield must be mounted by means of a bracket as shown in the figure below.

Control Wiring

The control wiring must be shielded. The shield must be mounted to the clamp supplied on the drive. See the figure below.

Motor Wiring

Either shielded or unshielded cables can be used for the motor. If unshielded motor cables are used, RFI emissions will be greater. If shielded motor cables are used, the shield must be connected both to the enclosure of the drive and to the motor enclosure. It is important to connect the shield by means of a clamp, so as to avoid inter-twisted cable ends.

Typical Wiring and Setup Examples

The following examples show some typical HVAC installations. The power and control connections, and the parameter settings for each example are shown. Details of the parameters are in the Drive Setup section. It may be helpful to find the example closest to the requirements of your installation and use it as a guide.

Example 1:

A fan is to be speed controlled between 6 and 60 Hz. A 0 to 10 V DC potentiometer is used as the control signal.

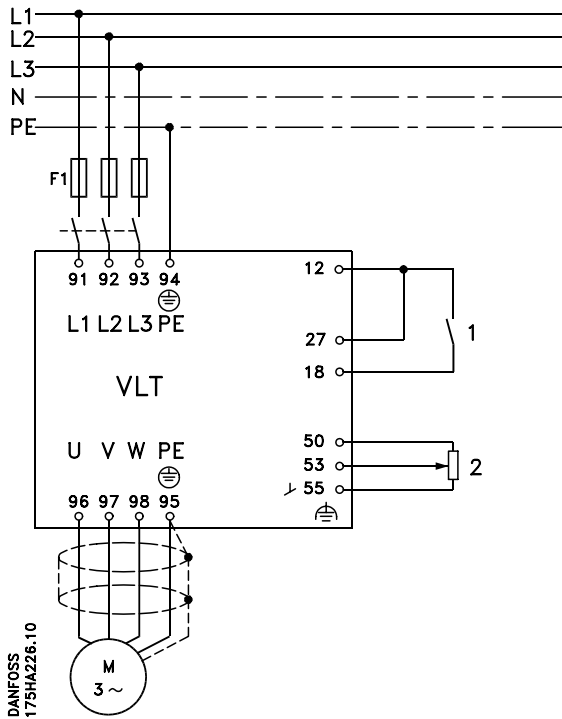

NOTE:

A shield for control wires is to be connected in accordance with the installation instructions.

All settings are based on factory settings.

Be sure to check the motor data settings (parameters 104, 105 and 107, or the Quick Setup menu items 1, 2 and 3). They must be set based upon the actual motor used.

- 1 = Start/Stop
- 2 = 1 kW potentiometer

External safety interlocks can be connected between terminals 12 and 27.

The following must be programmed:

| Function | Parameter # | Parameter Value | Data Value # |
|---------------------|-------------|-----------------|--------------|
| Safety interlock | 003 | KEY HOA w. stp | [1] |
| Minimum frequency | 201 | 6 Hz | |
| maximum frequency | 202 | 60 Hz | |
| Reference (voltage) | 412 | 0 to 10 V DC | [2] |
| Reference (current) | 413 | No operation | [0] |

Example 2:

In a ventilating system, the ability to reverse the fan in the case of fire is required.

The control signal used is 4 to 20 mA, corresponding to 10 to 100% motor speed, typically 6 to 60 Hz.

A remote indication of motor speed is required. The signal for that is to be 4 to 20 mA, with 4 mA corresponding to 0 Hz, and 20 mA corresponding to 60 Hz.

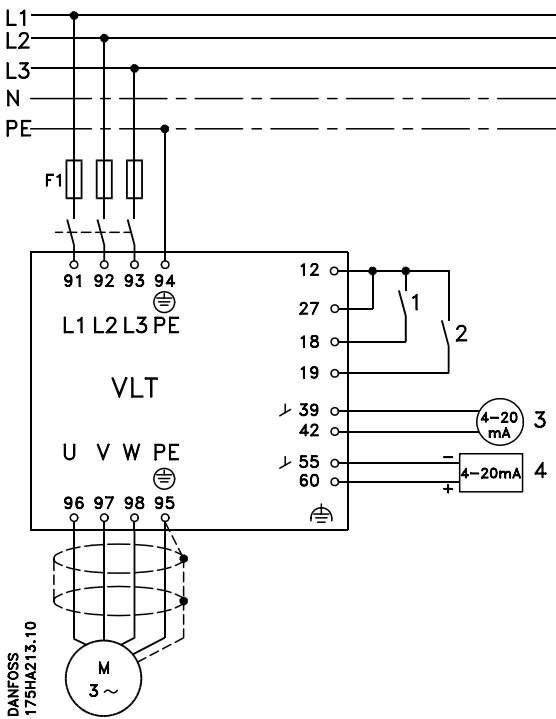

NOTE:

A shield for control wires is to be connected in accordance with the installation instructions.

All settings are based on factory settings.

Be sure to check the motor data settings (parameters 104, 105 and 107, or the Quick Setup menu items 1, 2 and 3). They must be set based upon the actual motor used.

- 1 = Start/Stop
- 2 = Reversing
- 3 = 4 to 20 mA output speed signal
- 4 = 4 to 20 mA input speed reference

External safety interlocks can be connected between terminals 12 and 27.

The following must be programmed:

| Function | Parameter # | Parameter Value | Data Value # |
|---------------------|-------------|----------------------|--------------|
| Safety interlock | 003 | KEY HOA w. stp | [1] |
| Minimum frequency | 201 | 6 Hz | |
| Maximum frequency | 202 | 60 Hz | |
| 0- f_{MAX} | 407 | $f_{MAX}=4$ to 20 mA | [20] |
| Reference (voltage) | 412 | No operation | [0] |
| Reference (current) | 413 | 4 to 20 mA | [2] |

Example 3:

A fan is to be controlled manually by means of a 0 to 10 V DC potentiometer corresponding to 10 to 60 Hz. A thermistor is installed in the motor to obtain optimum motor protection. The thermistor is to be connected to the drive to shut down the drive in case of motor overtemperature.

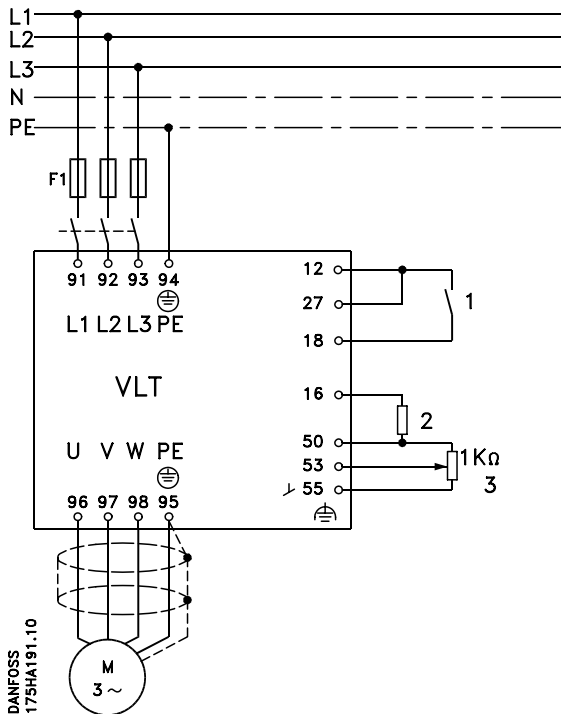

NOTE:

A shield for control wires is to be connected in accordance with the installation instructions.

All settings are based on factory settings.

Be sure to check the motor data settings (parameters 104, 105 and 107, or the Quick Setup menu items 1, 2 and 3). They must be set based upon the actual motor used.

- 1 = Start/Stop
- 2 = Thermistor
- 3 = 1 k W Potentiometer

External safety interlocks can be connected between terminals 12 and 27.

The following must be programmed:

| Function | Parameter # | Parameter Value | Data Value # |
|------------------------|-------------|-----------------|--------------|
| Safety interlock | 003 | KEY HOA w. stp | [1] |
| Minimum frequency | 201 | 10 Hz | |
| Maximum frequency | 202 | 60 Hz | |
| Thermistor on term. 16 | 400 | THERMISTOR | [4] |
| REFERENCE (voltage) | 412 | 0 to 10 V DC | [1] |
| REFERENCE (current) | 413 | No operation | [0] |

Example 4:

Although three-wire "Start/Stop" is not commonly used for unattended operation, some installations may require it for operator safety.

A pump is to be controlled by means of a 0 to 10 V control signal, corresponding to 18 to 60 Hz.

"Start/Stop" is to be in the form of a three wire (no auto-restart) "Start/Stop".

A remote indication of output current is required. The signal for that is to be 0 to 20 mA.

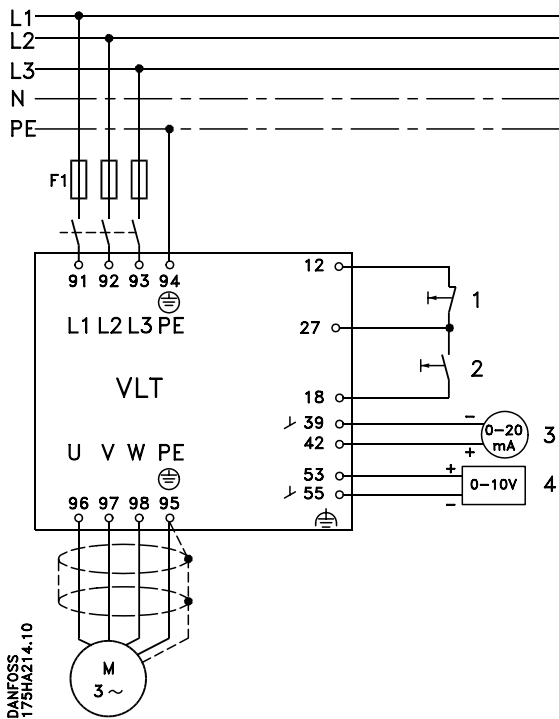

NOTE:

A shield for control wires is to be connected in accordance with the installation instructions.

All settings are based on factory settings.

Be sure to check the motor data settings (parameters 104, 105 and 107, or the Quick Setup menu items 1, 2 and 3). They must be set based upon the actual motor used.

- 1 = Stop
- 2 = Start
- 3 = 0 to 20 mA output signal (0- I_{MAX})
- 4 = 0 to 10 V control signal (0-100% speed)

External safety interlocks can be connected between terminals 12 and 27.

The following must be programmed:

| Function | Parameter # | Parameter Value | Data Value # |
|-------------------|-------------|---------------------------------------------------------|--------------|
| Safety interlock | 003 | KEY HOA w. stp | [1] |
| Power Up Mode | 014 | Stopped in local operation, using saved reference speed | [1] |
| Minimum frequency | 201 | 18 Hz | |
| Maximum frequency | 202 | 60 Hz | |
| START | 402 | LATCH START | [1] |
| STOP | 404 | STOP | [4] |
| 0- I_{MAX} | 407 | I_{MAX} 0-20 mA | [25] |
| Reference | 412 | 0-10 V DC | [1] |

Example 5:

The output frequency of the drive is to be controlled by means of digital signals from a PLC or floating point control. Whenever the output frequency is outside the 10 to 45 Hz range, the relay output is to be activated giving a signal to the PLC.

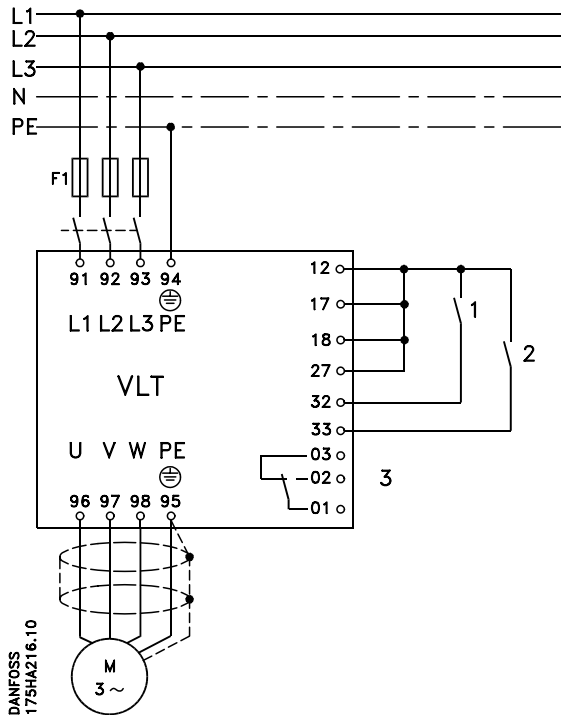

NOTE:

A shield for control wires is to be connected in accordance with the installation instructions.

All settings are based on factory settings.

Be sure to check the motor data settings (parameters 104, 105 and 107, or the Quick Setup menu items 1, 2 and 3). They must be set based upon the actual motor used.

- 1 = Speed up
- 2 = Speed down
- 3 = Relay is activated when the output frequency is outside the 10 to 45 Hz range by closing 01-02.

External safety interlocks can be connected between terminals 12 and 27.

The following must be programmed:

| Function | Parameter # | Parameter Value | Data Value # |
|----------------------------|-------------|-----------------|--------------|
| Safety interlock | 003 | KEY HOA w. stp | [1] |
| Minimum frequency | 201 | 0 Hz | |
| Maximum frequency | 202 | 60 Hz | |
| Frequency too low | 210 | 10 Hz | |
| Frequency too high | 211 | 45 Hz | |
| Speed up and down | 401 | FREEZE REF. | [2] |
| Speed up and down | 406 | SPEED UP/DOWN | [1] |
| Frequency warning on relay | 409 | OUT FREQ RGE | [11] |

Example 6:

A ventilation system is to be run at six preset speeds, depending on the time of the day or night. Maximum speed is 60 Hz.

1. Speed 6 Hz (10%)
2. Speed 12 Hz (20%)
3. Speed 18 Hz (30%)
4. Speed 24 Hz (40%)
5. Speed 42 Hz (70%)
6. Speed 60 Hz (100%)



NOTE:

A shield for control wires is to be connected in accordance with the installation instructions. All settings are based on factory settings.

Be sure to check the motor data settings (parameters 104, 105 and 107, or the Quick Setup menu items 1, 2 and 3). They must be set based upon the actual motor used.

- 1 = Setup choice
- 2 = Start/stop
- 3 = Digital reference choice
- 4 = Digital reference choice

External safety interlocks can be connected between terminals 12 and 27.

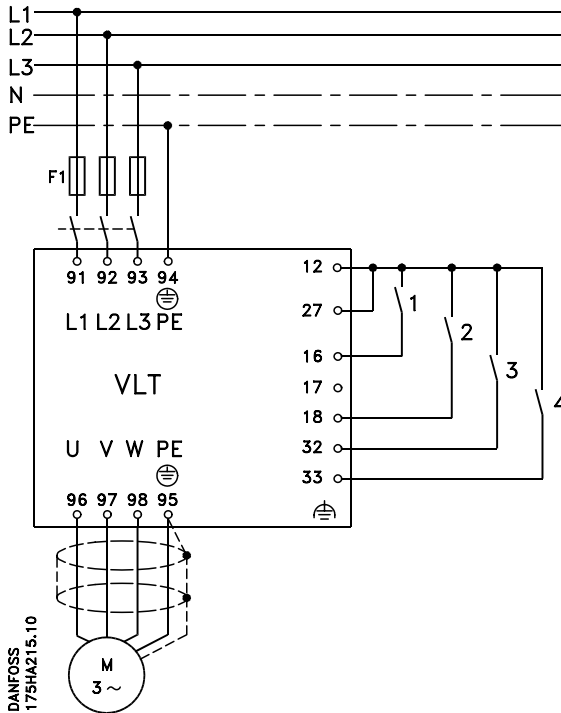

How to activate different speeds

| Terminal | | | Setup | | Digital reference | | | |
|----------|----|----|-------|---|-------------------|------|-----|-----|
| 33 | 32 | 16 | 1 | 2 | 1 | 2 | 3 | 4 |
| 0 | 0 | 0 | X | 0 | 10% | 0 | 0 | 0 |
| 0 | 1 | 0 | X | 0 | 0 | 20% | 0 | 0 |
| 1 | 0 | 0 | X | 0 | 0 | 0 | 30% | 0 |
| 1 | 1 | 0 | X | 0 | 0 | 0 | 0 | 40% |
| 0 | 0 | 1 | 0 | X | 70% | 0 | 0 | 0 |
| 0 | 1 | 1 | 0 | X | 0 | 100% | 0 | 0 |

“1” means that 24 V DC is connected to the terminal.

The following must be programmed:

| Function | Parameter # | Parameter Value | Data Value # |
|--------------------------|-------------|-----------------|--------------|
| Choice of setup | 001 | MULTI-SETUP | [5] |
| Safety interlock | 003 | KEY HOA w. stp | [1] |
| Choice of setup | 400 | SETUP SELECT | [3] |
| Digital reference choice | 406 | DIGITAL REF. | [0] |
| Setup 1 | | | |
| Maximum frequency | 202 | 60 Hz | |
| Digital reference 1 | 205 | 10% | |
| Digital reference 2 | 206 | 20% | |
| Digital reference 3 | 207 | 30% | |
| Digital reference 4 | 208 | 40% | |
| Setup 2 | | | |
| Maximum frequency | 202 | 60 Hz | |
| Digital reference 1 | 205 | 70% | |
| Digital reference 2 | 205 | 100% | |

Example 7:

In a pump system, a constant pressure of 5 PSI is to be maintained. The integrated PID controller in VLT Series 3500 is used. Normal regulation is desired, in which the speed is reduced when the pressure increases and vice versa.

The transmitter used is a 4 to 20 mA, 0 to 10 PSI type. Since a pressure of 5 PSI is required, this corresponds to 50% of the working range of the transmitter, which in turn corresponds to the setpoint programmed as the internal setpoint in the drive. (Digital reference = 50%). The minimum speed must be 10 Hz and the maximum speed 60 Hz.

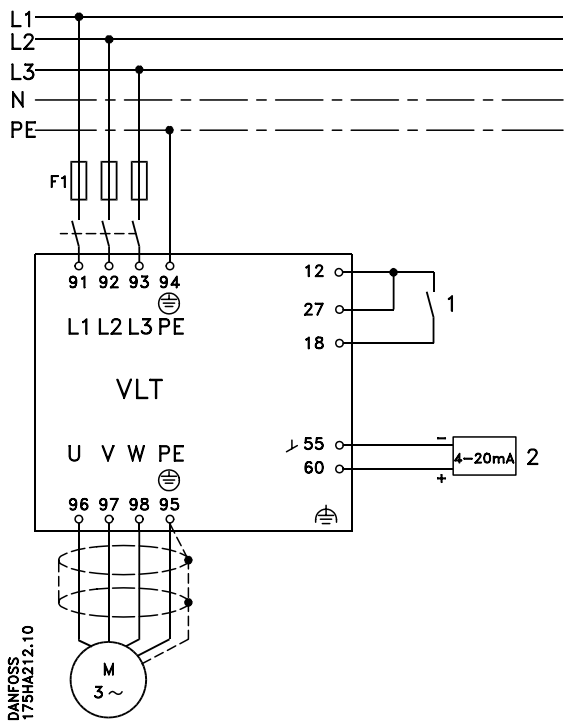

NOTE:

A shield for control wires is to be connected in accordance with the installation instructions.

All settings are based on factory settings.

Be sure to check the motor data settings (parameters 104, 105 and 107, or the Quick Setup menu items 1, 2 and 3). They must be set based upon the actual motor used.

- 1 = Start/Stop
- 2 = Feedback pressure transmitter 4 to 20 mA, 0 to 10 PSI

External safety interlocks can be connected between terminals 12 and 27.

The following must be programmed:

| Function | Parameter # | Parameter Value | Data Value # |
|-----------------------------|-------------|-----------------------|--------------|
| Safety interlock | 003 | KEY HOA w. stp | [1] |
| Activation of PID-regulator | 101 | CLOSED LOOP | [2] |
| Feedback type | 114 | CURRENT | [1] |
| Regulator range | 120 | Application dependent | |
| Proportional gain | 121 | Application dependent | |
| Integration time | 122 | Application dependent | |
| Minimum speed | 201 | 10 Hz | |
| Maximum speed | 202 | 60 Hz | |
| Internal setpoint | 205 | 50% | |
| Current signal | 413 | 4 to 20 mA | [2] |

Example 8:

In a ventilation system the temperature is to be adjusted by means of a 0 to 10 V potentiometer. The selected temperature must be kept constant, and the internal PID controller in the drive is to be used. The regulation required is of the inverse type; this means that when the temperature goes up, the fan speed increases so that more air is supplied.

The transmitter used is a temperature sensor with a working range of 32 to 120°F, 4 to 20 mA. In order to carry out inverse regulation, the drive is programmed to convert the temperature transmitter signal (4 to 20 mA) to 20 to 4 mA.

The minimum and maximum speeds are 10 and 60 Hz.

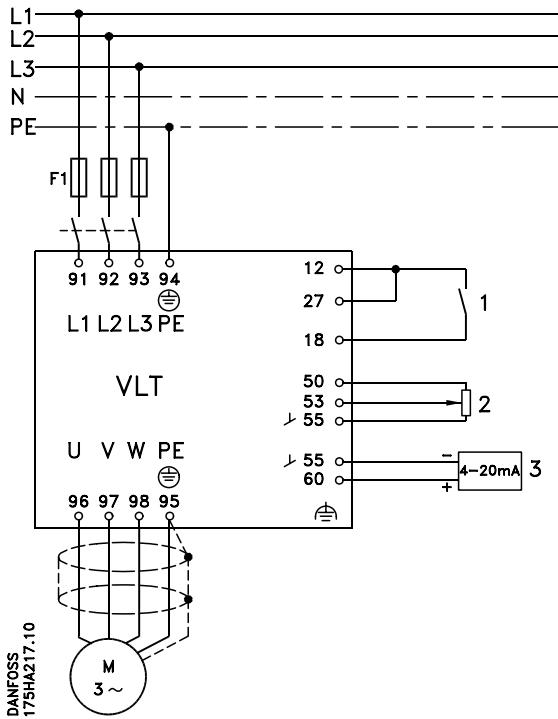

NOTE:

A shield for control wires is to be connected in accordance with the installation instructions.

All settings are based on factory settings.

Be sure to check the motor data settings (parameters 104, 105 and 107, or the Quick Setup menu items 1, 2 and 3). They must be set based upon the actual motor used.

- 1 = Start/Stop
- 2 = Temperature reference 32 to 120°F, 0 to 10 V
- 3 = Temperature transmitter 32 to 120°F, 4 to 20 mA

External safety interlocks can be connected between terminals 12 and 27.

The following must be programmed:

| Function: | Parameter # | Parameter Value | Data Value # |
|-----------------------------|-------------|-----------------------|--------------|
| Safety interlock | 003 | KEY HOA w. stp | [1] |
| Activation of PID-regulator | 101 | CLOSED LOOP | [2] |
| Feedback type | 114 | CURRENT | [1] |
| Regulator range | 120 | Application dependent | |
| Proportional gain | 121 | Application dependent | |
| Integration time | 122 | Application dependent | |
| Minimum speed | 201 | 10 Hz | |
| Maximum speed | 202 | 60 Hz | |
| Current signal | 413 | 20 to 4 mA | [4] |

Example 9:

Remote Hand/Off/Auto control is desired.

The Local/Hand, and Remote/Hand switches are to provide these functions. The “Hand” reference is a 0 to 10 V signal from a potentiometer. The “Auto” signal is a 4 to 20 mA reference from a set point controller.

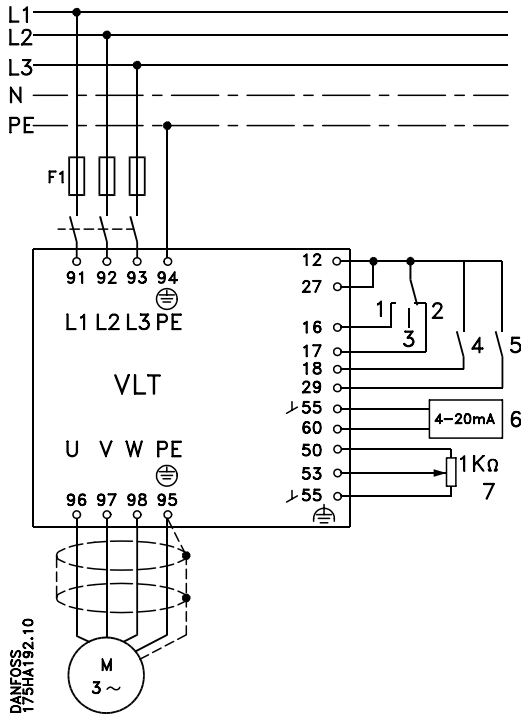

NOTE:
 A shield for control wires is to be connected in accordance with the installation instructions.

All settings are based on factory settings.

Be sure to check the motor data settings (parameters 104, 105 and 107, or the Quick Setup menu items 1, 2 and 3). They must be set based upon the actual motor used.

- 1 = Activation of Local/Hand mode
- 2 = Activation of Remote/ Auto mode
- 3 = Stop
- 4 = Start Auto mode
- 5 = Pulse Start Hand mode
- 6 = Auto mode reference, 4 to 20 mA
- 7 = Hand mode reference, 0 to 10 V

External safety interlocks can be connected between terminals 12 and 27.

The following must be programmed:

| Function: | Parameter # | Parameter Value | Data Value # |
|--------------------|-------------|-----------------|--------------|
| H-O-A position | 003 | EXTERNAL HOA | [2] |
| Activation of Hand | 400 | EXT. HOA HAND | [5] |
| Activation of Auto | 401 | EXT. HOA AUTO | [7] |
| Pulse Start Hand | 405 | LATCH ST. HAND | [4] |
| Auto reference | 413 | 4 to 20 mA | [2] |
| Hand reference | 420 | VOLTAGE | [0] |

Control Panel

Local/Hand and Remote/Auto Control

The start/stop and speed reference functions of the drive are controlled by these controls.

Local/Hand

The drive is commanded to energize the run relay and start. Any customer remote start/stop contacts will be overridden. The drive will also follow the local speed reference set using the “+” and “-” keys. If parameter 003 is set for KEY HOA W.STP and parameter 404 is set to MTR. COAST, opening the safety interlock circuit between terminals 12 and 27 will stop the drive. While this won't give a fault indication at the drive, if parameter 409 is set to ENABLED noWR (enabled no warning), relay 01 will de-energize. Then this interlock opens, just as it does in a fault condition.

Remote/Auto

The drive is commanded to pick up the run relay and start only if the customer remote start contact is closed. The drive also follows the specified external speed reference signal.

Setting H-O-A Control

In parameter 003 it is possible to choose between three different ways of implementing the H-O-A function:

1. Control from the drive keypad.
2. Control from the drive keypad, with the ability to stop the drive remotely.
3. Remote control.

External Selection of Local/Hand and Remote/Auto

It is possible to choose between Local/Hand or Remote/Auto mode by means of the digital inputs.

The Local/Hand mode is activated when one of the digital input terminals 16 (parameter 400) or terminal 19 (parameter 403) is programmed for External H-O-A Hand, and 24 V DC from terminal 12 is applied to that terminal.

The Remote/Auto mode is activated when digital input terminal 17 (parameter 401) or terminal 18 (parameter 402) is programmed for External H-O-A Auto, and 24 V DC from terminal 12 is applied to that terminal.

If no terminals are activated using the 24 V DC from terminal 12, the output frequency of the drive will ramp down to 0 Hz.

External Local/Hand and Remote/Auto References

In parameter 420 it is possible to choose the reference to be used in the External Hand mode.

There is a choice of three options:

1. Voltage reference
2. Current reference
3. Digital speed up/down

Start Signal for External Hand Mode

When Local/Hand mode is selected through terminal 16 (parameter 400) or terminal 19 (parameter 403), it is necessary to give the drive a start command to start the drive. Terminal 29 or 19 can be programmed to give the required start command. If 24 V DC is connected to terminal 19 or terminal 29 for a minimum of 20 milliseconds, the inverter starts and the drive supplies the motor with a frequency depending on the reference.

When the 24 V DC signal is removed from terminal 16 or 19, the drive stays in Local/Hand mode, but the inverter stops.

External Remote/Auto Mode

When Remote/Auto mode is activated through terminal 17 (parameter 401) or terminal 18 (parameter 402), the drive will be controlled by means of normal remote operation.

How to Operate the VLT Series 3500

In order to program and locally control the drive, use the control panel on the front of the drive.

The control panel serves a dual purpose:

- Local operation
- Programming

The control panel consists of:

- a display, which gives information about the drive, the process, or the status of the drive's program parameters.
- eight keypad switches, which allow the user to select the display, make changes to the drive's status, and make changes to the drive's program parameters.
- two light emitting diodes, which indicate:
green (On): the drive is connected to the AC line.
red (Alarm): an alarm or fault condition exists.

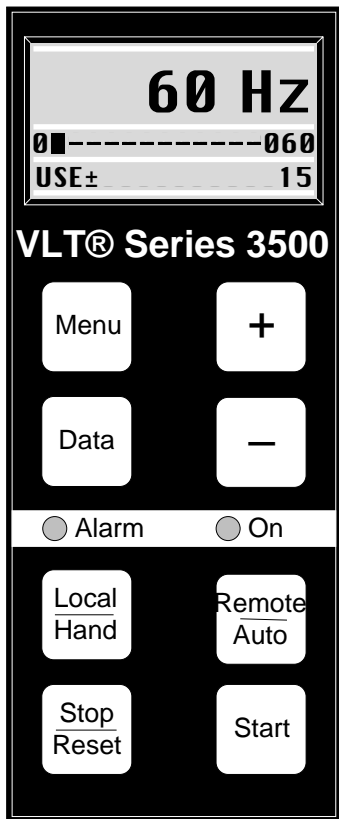

The VLT Display

The display is designed to be lit whenever the drive is connected to the AC line.

The display consists of 3 lines:

- Line A Seven large alphanumeric characters
- Lines B and C Fourteen smaller alphanumeric characters on each line

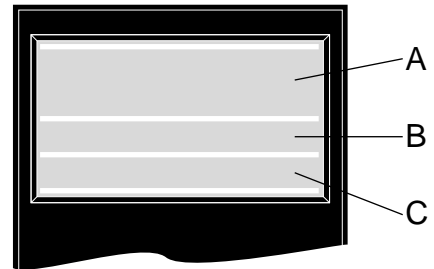

Remote Mounting of the Control Panel

The control panel can be removed from the drive cover and remotely mounted. An adaptor plate and 10' cable is available. The control panel and adaptor plate can be installed on a NEMA 12 enclosure and retain the NEMA rating.

The Keypad Switches

The following keypad switches are on the control panel of the drive. The next page gives a description of the individual keys and their functions.

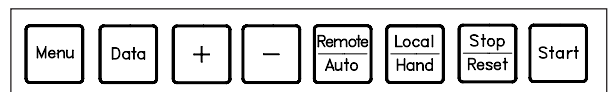

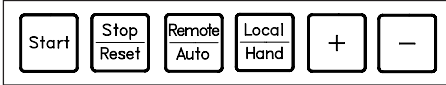

Keys for Local Operation

The following keys are used for local operation:





 This key is used for starting up the VLT Series 3500 .

 This key is used for local control of the drive from this control panel. When this key is depressed, the operating panel display looks as shown below. This key can be deactivated through parameter 008 if desired.

 When in “Local” mode these keys are used to increase or decrease the output frequency of the drive.

STOP
 This key is used to stop the connected motor. If stop is activated, the run relay will drop out and the top line of the display will start to flash. This key does not turn off the AC line and therefore cannot be used as a safety switch. This will stop the drive when it is in either Local/Hand or Remote/Auto mode. This key can be deactivated through parameter 007 if desired.

 **NOTE:** Whether in Local/Hand or Remote/Auto mode, it is necessary to press the Start key to restart the drive.

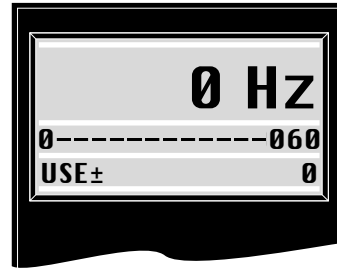

RESET
 This key is also used to reset the drive after a fault trip that is not automatically reset.

Shown below is the appearance of the display when in local mode and the drive is ready to run.



In the “Local” mode, the second line in the display will indicate the relative speed. If all squares are filled, it indicates that the drive is running at the commanded speed. Hollow squares indicate that a stop command has been given and there is a speed command or that the drive is in the process of accelerating to the commanded speed. If a run command is given, the drive will accelerate to the commanded speed. A complete row of dashes indicates that there is no speed command. The value of the local speed command, in Hz, is shown in the lower right corner of the display whether the drive is running or stopped.

 This key is used to switch to the Remote/Auto mode in which the drive is controlled using external Run/Stop and speed reference signals.

 These keys are used for switching between local operation and remote operation. When Remote/Auto is selected REMOTE will be indicated in the middle of the third row of the display.

Display Mode

In normal operation, the VLT Series 3500 starts up in display mode. In the display mode, there is the ability to choose different readouts. There are two different possible displays, the Standard Display, and the Extended Display. Parameter 606 allows the selection of either the Standard Display or the Extended Display. The display readouts can be selected by means of the “+” and “-” keys:

Standard Display

1. Frequency Hz
2. Feedback
3. Current A
4. Power kW
5. Energy kWh
6. Motor voltage V
7. Reference %

Extended Display

1. Reference %
2. Frequency Hz
3. Display/Feedback %
4. Current A
5. Torque %
6. Power kW
7. Power HP
8. Energy kWh
9. Motor voltage V
10. DC voltage V
11. Thermal motor load %
12. Thermal inverter load %

By default, the top display line shows the value of the selected readout and the second line displays a description of the readout. Parameter 605 makes it possible to display the value of a second readout on the second line, instead of the description. This can be useful when, for example, the PID controller is being programmed. It is possible to read out the reference (setpoint) and the feedback signal at the same time.

Programming

Programming is carried out by changing the data values for the various parameters. The parameters have been grouped into a menu format. The most commonly used parameters have been grouped together into a Quick Setup Menu. All the parameters, including those also in the Quick Setup Menu are available in the Extended Menu. If a parameter in the Quick Setup Menu is changed, it is automatically changed in the Extended Menu as well.

The drive can also be run in four different setups. Many parameters can be programmed differently in each setup. Through the control inputs, the desired drive setup can be chosen. This allows application-dependent programming to be done. For example, one setup may have no PID regulation, while another setup has PID regulation.

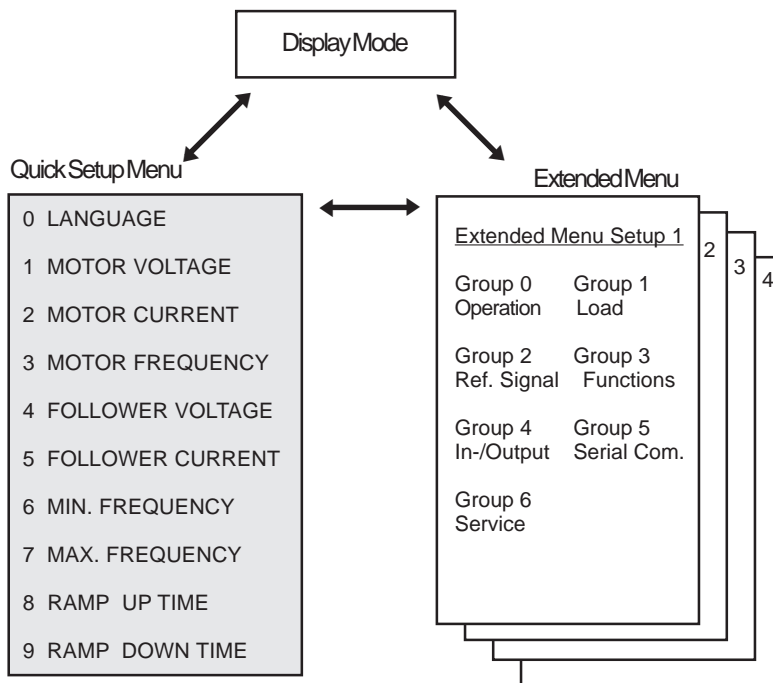

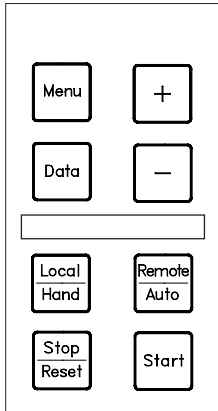
Functions of the Keys

The eight keys on the control panel of the drive are used for programming as follows:



MENU KEY Press this key to toggle from Display mode to Quick Setup mode. This key is also used for switching from Data mode to Menu mode.



DATA KEY Press this key to toggle from Menu mode to Data mode or Display mode. This key is also used for moving the cursor between the decimal places of numerical data values. The program automatically leaves Data mode after 20 seconds if no operation is registered.



+ KEY AND - KEY These keys are used for scrolling through the different Menu Modes and their parameters and for choosing a specific parameter value or for scrolling parameter data. They are also used for changing the speed when in Local mode.



LOCAL/HAND KEY This key is used for selecting local operation. This key can be deactivated by using parameter 008.



REMOTE/AUTO KEY This key is used for selecting remote operation. This key can be deactivated by using parameter 009.



STOP/RESET KEY This key is used to stop the drive and for resetting if a trip occurs. The top line of the display flashes when the drive has been stopped using this key. The start key must then be pressed to restart the drive. The reset function of this key can be deactivated using parameter 006. The stop function of this key can be deactivated using parameter 007.



START KEY This key is used for starting the drive. If the drive has been stopped using the Stop/Reset key, the Start key must be pressed to restart the drive.

Combinations of Control Panel Keys

MENU AND DATA KEYS If these keys are pressed simultaneously, the system switches to Display mode from any other mode.



MENU AND + KEYS If these keys are pressed simultaneously, the system switches to Extended Menu from any mode.



MENU AND - KEYS If these keys are pressed simultaneously, the system switches to the Quick Set Up Menu from any mode.



MENU, DATA and LOCAL/HAND If these keys are pressed and held while power is applied to the drive, all of the drive's parameters and history logs will be reset. These three buttons must be held until the third line of the display shows "init eeprom".



STOP/RESET Holding down Stop/Reset while pressing other keys allows access to the function of the other keys when a drive fault would otherwise have made the other key inactive.

Display Mode

Shows value and unit
 Defines the display Status, and source of control

Direction of rotation
 Setup number

Quick Set Up Menu
 Enter from the Display mode by pressing the "Menu" key. Enter from any mode by pressing the "Menu and "-" keys.

Data value selected
 Parameter name
 Quick Setup Menu number

Select other parameters in the Quick Set Up Menu by pressing either the "+" or "-" key.

Quick Set Up Data Mode
 Enter from the Quick Setup menu by pressing the "Data" key.

Flashing, selcted data value
 Parameter name
 Quick Setup Menu number

Change the displayed data by pressing either the "+" or "-" key.

Extended Menu Mode
 Enter from any mode by pressing the "Menu" and the "+" keys.

Shows value and unit
 Flashing group number

Change the group displayed by pressing either the "+" or the "-" key.
 Data value

Extended Parameter Mode

Enter from the Extended Menu mode by pressing the “Menu” key.

Flashing parameter number

 = Cursor flashes
Selected data value



Change the displayed parameter by pressing the “+” or the “-” key.

Extended Data Mode

Enter from the Extended Parameter mode by pressing the “Data” key.

 = Cursor flashes
Selected data value





Change the parameter’s value by pressing the “+” or the “-” key. For numeric parameters, pressing the “Data” key selects the digit that is changed by the “+” and “-” keys.

Local/Hand Mode

Enter from any mode by pressing “Local/Hand” key.



Display readout of local output frequency

Shows speed

filled-in when running 
unfilled when stopped 
with a speed command present



Change speed using the “+” and the “-” keys.

 Open rectangles represent the local speed command.
 Solid rectangles represent the drive’s actual speed.

Alarm Mode

Reset mode
Cause of alarm



NOTE:



If the display reads TRIP, the drive will be stopped due to a fault. If the cause of the fault has been eliminated, pressing “Reset” will start the drive.

If the display reads TRIP LOCK, the drive will be stopped. To restart it, the AC power to the drive must be removed and reapplied. If the cause of the fault has been eliminated, pressing the “Reset” key will then restart the drive.

Menu Access Keys

DANFOSS
175HA193.10

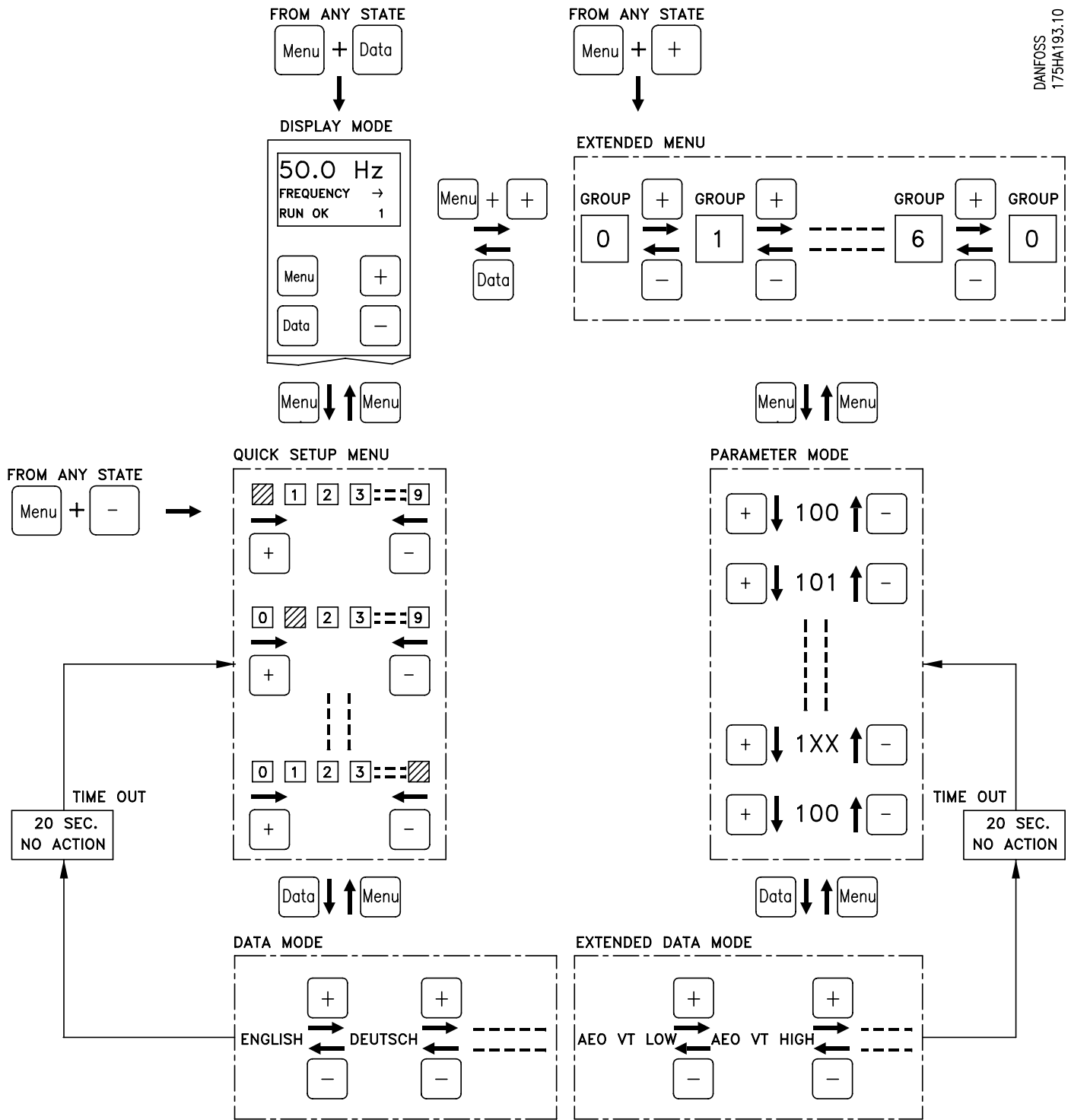

Drive Setup

When the drive is first powered up, the items in the Quick Setup menu should be viewed and changed as required. The Quick Setup menu items are shown below. If preferred, these items can be viewed and changed from the Extended menu.

| Quick setup no. | Extended menu | Designation | Settings | Data Entry |
|-----------------|---------------|-----------------|---------------------------|----------------------------------|
| 0 | 000 | Language | Choose from six languages | Choose English (typical) |
| 1 | 104 | Motor voltage | Check nameplate on motor | Enter line voltage 460 (typical) |
| 2 | 107 | Motor current | Check nameplate on motor | Enter FLA motor amps |
| 3 | 105 | Motor frequency | Check nameplate on motor | Enter 60 Hz (typical) |
| 4 | 412 | Speed reference | Select reference range | Choose 0 to 10 V DC (typical) |
| 5 | 413 | Speed reference | Select reference range | Choose 4 to 20 mA (typical) |
| 6 | 201 | Min. frequency | Select desired frequency | Enter 20 Hz (typical) |
| 7 | 202 | Max. frequency | Select desired frequency | Enter 60 Hz (typical) |
| 8 | 215 | Ramp up | Select desired time | Enter 30 sec (typical) |
| 9 | 216 | Ramp down | Select desired time | Enter 30 sec (typical) |

Return to Factory Defaults

It is possible to globally return all parameters to the factory default settings. If undocumented changes have been made to the settings and the drive is not responding as it should, it is possible to start over.

Returning to the factory defaults may affect **all** parameters. Be sure to review all parameters for desired settings after returning to the factory defaults.

There are three ways to return to factory defaults.

1. One way initializes the EEPROM and therefore resets everything. To do this, first remove power from the drive. Then press and hold the "Menu", "Data" and "Local/Hand" keys while reapplying power. Release the keys after the third line in the display reads "init eeprom".
2. If you wish to retain the settings of parameters 501 (PC communication), 821, 822, 904 and 918 (Profibus communication), the cumulative kWh and total running hours, use Parameter 604 to reset to factory settings instead. See parameter 604. Set it to INITIALIZE [3] .
3. It is also possible to return the parameter sets to the factory defaults one set at a time or all at once. If multiple settings are used, it may be desirable to change only one of them, or change them one at a time. Use the procedure for parameter 001 and parameter 002 to copy the factory defaults to a single parameter set or to all four parameter sets.

Lockout

Unwanted programming can be prevented by opening switch pin 01 on the control card. When the switch pin is open, changes cannot be made to the programming. The Local/Hand, Stop/Reset, Remote/Auto, and Start keys are functional, but the programming keys are not. "LOCK OPEN" is displaced on the third line of the display when programming changes are attempted with the switch pin open.

Control functions can be locked out individually. See parameter 006 through 010.

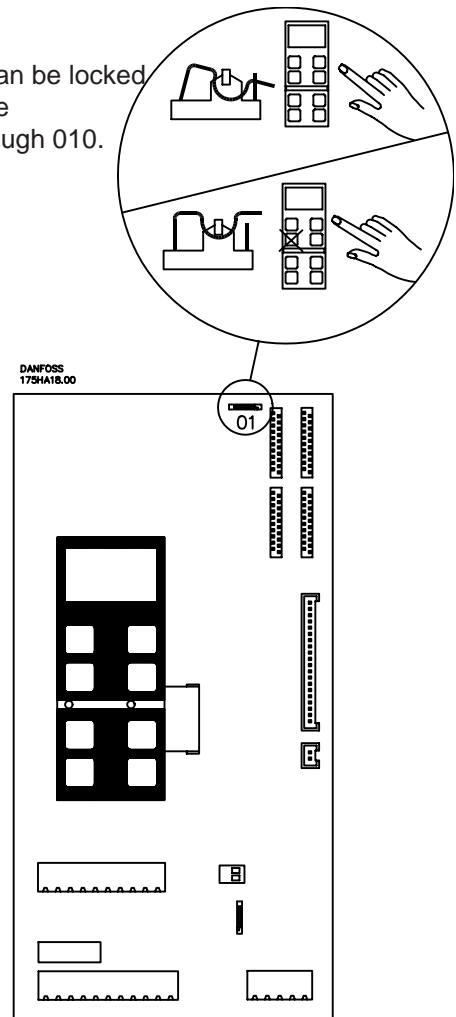

Standard HVAC Operation Parameters

| Operation and Display | | |
|-----------------------|-------------------------|--------------------------------------------------------|
| 000 | Language | ENGLISH |
| 001 | Setup Selection | SETUP 1 |
| 002 | Setup Copy | DO NOT COPY |
| ✓ 003 | Local/Remote (HOA) | KEY HOA w. stp |
| 004 | Local Reference | No setting needed |
| 005 | User Read-out at Max | 100 |
| 006 | Local Reset (EN/DIS) | ENABLE |
| 007 | Local Stop (En/Dis) | ENABLE |
| 008 | Local Loc/Hand (En-Dis) | ENABLE |
| 009 | Local Rem/Aut (En/Dis) | ENABLE |
| 010 | Local Ref. (En/Dis) | ENABLE |
| 011 | Reset kWh Counter | NO RESET |
| 012 | Reset Time counter | NO RESET |
| ✓ 014 | Power-up Mode | AUTO RESTART |
| 015 | Setup Program | SETUP=P001 |
| Load and Motor | | |
| ✓ 100 | Load Type | single motor: ENERGY VT.H multi-motor: VT MODE HIGH |
| 101 | Speed Control (Fdbk) | OPEN LOOP |
| 102 | Current Limit Control | PROGRAM.VALUE |
| ✓ 103 | Motor Power (kW) | set for the rated size (in kW) |
| ✓ 104 | Motor Voltage | as required |
| ✓ 105 | Motor Frequency | 60 Hz |
| ✓ 107 | Motor Current | per drive rating |
| 109 | Starting Voltage | No setting usually needed |
| 114 | Feedback Type | CURRENT |
| 115 | Display @ Min Fdbk | 0000 |
| 116 | Display @ Max Fdbk | 0100 |
| 117 | Display Unit | % |
| 119 | Feed Forward Factor | 100 |
| 120 | Controller Range | 100 |
| 121 | Proportional Gain | 00.01 |
| 122 | Integral Time | OFF [999 on RS-485] |
| 123 | Differentiation Time | OFF |
| 124 | Low Pass Filter | 00.0 |
| 125 | Feedback Factor | 100 |
| References and Limits | | |
| ✓ 201 | Min. Freq. (Follower) | fan 06.0 pump: 16.0 |
| ✓ 202 | Max. Freq. (Follower) | 060.0 |
| 203 | Jog Freq. | 010.0 |
| ✓ 204 | Dig. Ref. Type (effect) | EXT. ON/OFF |
| 205 | Dig. Ref. 1 (%) | 000.0 |
| 206 | Dig. Ref. 2 (%) | 000.0 |
| 207 | Dig. Ref. 3 (%) | 000.0 |
| 208 | Dig. Ref. 4 (%) | 000.0 |
| ✓ 209 | Current Limit (A) | 110% of rated current |
| 210 | Warn. Freq. Low | 000.0 |
| ✓ 211 | Warn. Freq. High | 66.0 |
| 212 | Warn. Curr. Low | 0.0 A |
| 213 | Warn. Curr. High | the drive's maximum current |
| 214 | Ramp time | LINEAR |
| ✓ 215 | Ramp-up Time | fan: 60 SEC pump: 10 SEC |
| ✓ 216 | Ramp-down Time | fan: 60 SEC pump: 10 SEC |
| ✓ 217 | Alt. Ramp-up Time | fan: 60 SEC pump: 10 SEC |
| ✓ 218 | Alt. Ramp-down Time | fan: 60 SEC pump: 10 SEC |
| 219 | Freq. Bypass 1 | 120 Hz |
| 220 | Freq. Bypass 2 | 120 Hz |
| 221 | Freq. Bypass 3 | 120 Hz |
| 222 | Freq. Bypass 4 | 120 Hz |
| 223 | Freq. Bypass Width (%) | 0% |
| ✓ 224 | Carrier Freq. | small units: 14.0 kHz large units: 4.5 kHz |
| ✓ 225 | Variable Carrier Freq. | HIGH CARR @LO (or ENABLE) |
| 232 | Idle Running Current | use default |

| Functions and Timers | | |
|-------------------------|---------------------------|--------------------|
| 301 | Start Freq. | 00.0 |
| 302 | Start Delay | 0.0 |
| 303 | High Starting Torque Time | 0.0 |
| 304 | Mains Failure (stop) | NORM PWR DWN |
| ✓ 305 | Flying Start | SAME DIRECT |
| 306 | DC Braking Time | 0000.0 |
| 307 | DC Braking Cut-in Freq. | 001.0 |
| 308 | DC Braking Voltage | use the default |
| ✓ 309 | Reset Mode (Counts) | AUTOMATIC X10 |
| ✓ 310 | Trip Delay, Current Limit | 60 |
| ✓ 311 | Trip Delay, Inv. Fault | 02 |
| 312 | Max. Auto Restart Time | 05 |
| 313 | Motor Check | OFF |
| 314 | Motor Pre-heat | OFF |
| 315 | Motor Term. Protection | TRIP 1 |
| 316 | Relay 1 ON Delay | 000.00 |
| ✓ 317 | Relay 1 OFF Delay | 002.00 |
| Inputs and Outputs | | |
| 400 | Binary Input 16 | RESET |
| 401 | Binary Input 17 | FREEZE REF. |
| 402 | Binary Input 18 | START |
| 403 | Binary Input 19 | REVERSING |
| 404 | Binary Input 27 (Stop) | MTR. COAST |
| 405 | Binary Input 29 | JOG |
| ✓ 406 | Binary Input 32/33 | SPEED UP/DOWN |
| ✓ 407 | Signal Output 42 | CURmax 4-20 mA |
| ✓ 408 | Signal Output 45 | Fmax 4-20 mA |
| ✓ 409 | Relay Output 01 | ENABLED noWR |
| 410 | Relay Output 04 | RUNNING |
| 411 | Analog Reference Type | LINEAR |
| ✓ 412 | Term. 53 Input Voltage | NO OPERATION |
| ✓ 413 | Term. 60 Input Current | 4-20 mA |
| ✓ 414 | Time Out | 005 |
| 415 | Time Out Function | FREEZE |
| 420 | Ext. Hand Ref. Type | VOLTAGE 53 |
| Serial Communications | | |
| 500 | Address | 01 |
| 501 | Baud Rate | 9600 |
| 502 | Data Read-out | REFERENCE % |
| 503 | Coasting | OR |
| 504 | Q-stop | OR |
| 505 | DC Brake | OR |
| 506 | Start | OR |
| 507 | Direction | DIGITAL |
| 508 | Reset | OR |
| 509 | Setup Select | OR |
| 510 | Digital Speed Select | OR |
| 511 | Bus Jogging 1 | 010.0 |
| 512 | Bus Jogging 2 | 010.0 |
| 513 | Catch Up Value | 000 |
| 514 | Bus Bit 4 | Q STOP |
| 515 | Bus Bit 11/12 | CATCH UP SLOW DOWN |
| 516 | Bus Reference | 000.00 |
| 517 | Store Data Values | OFF |
| Service and Diagnostics | | |
| 600 | Operation Data | |
| 601 | Data Log | |
| 602 | Fault Memory | |
| 603 | Type Plate | |
| 604 | Operation Mode | RUN NORMAL |
| 605 | Personal Display Select | STANDARD DISPLAY |
| 606 | Display Mode | QUICK DISPLAY |
| ✓ 650 | VLT Type | |

If the control is initialized, the parameters indicated by "✓" will change to a default which is different than the choice suggested here. It may be desirable to reset those parameters to the selection shown above.

Extended Menu Structure

VLT Series 3500 menu structure, referred to as the Extended Menu, is divided into seven groups. These contain parameters that allow performance to be optimized and efficiency to be maximized. Although the default parameters are acceptable for most applications, they may not be ideal for your specific application. For optimum performance, review all parameters and reset those that are not optimum for your application.

The parameters of the Extended Menu are divided into seven groups, identified below.

Parameter groups:

| | | |
|---|-------------------------|---------|
| 0 | Operation and Display | 000-099 |
| 1 | Load and Motor | 100-199 |
| 2 | References and Limits | 200-299 |
| 3 | Functions and Timers | 300-399 |
| 4 | Inputs and Outputs | 400-499 |
| 5 | Serial Data Interface | 500-599 |
| 6 | Service and Diagnostics | 600-699 |

Parameter Numbers

Each parameter number consists of three digits. The digit to the left indicates the group. In each group, parameters are numbered from 0 and up. For example, the parameters in group 1 are numbered 100, 101, 102, etc.

Accessing the Various Parameters

When initially powered up, the display is in the Display mode. Press "Menu" and "+" simultaneously to go to the Extended Menu. The flashing number at the left of the second line of the display identifies the group accessed. Use the "+" and "-" keys to scroll through the menu groups. Press "Menu" again to access a specific parameter within a group. The flashing number will now be at the parameter within the group. Use the "+" and "-" keys to scroll through the list of parameter numbers.

Changing the Parameter Data Value

When a parameter has been selected and the data value is to be changed, press the "Data" key and then "+" or "-". The data value can be either a number or text. For numeric values, the digit to be changed can be selected by pressing the "Data" key as required. If a parameter in the current set is changed, the parameter change immediately affects the drive's operation. The Data mode is exited by pressing "Menu" or by waiting 20 seconds. The selected data value will then be saved to the EEPROM.



NOTE: The motor must be stopped before the data values of certain parameters are changed.

Leaving Data Mode

The data value is stored by pressing "Menu".

Speed Control Signal -- Open Loop

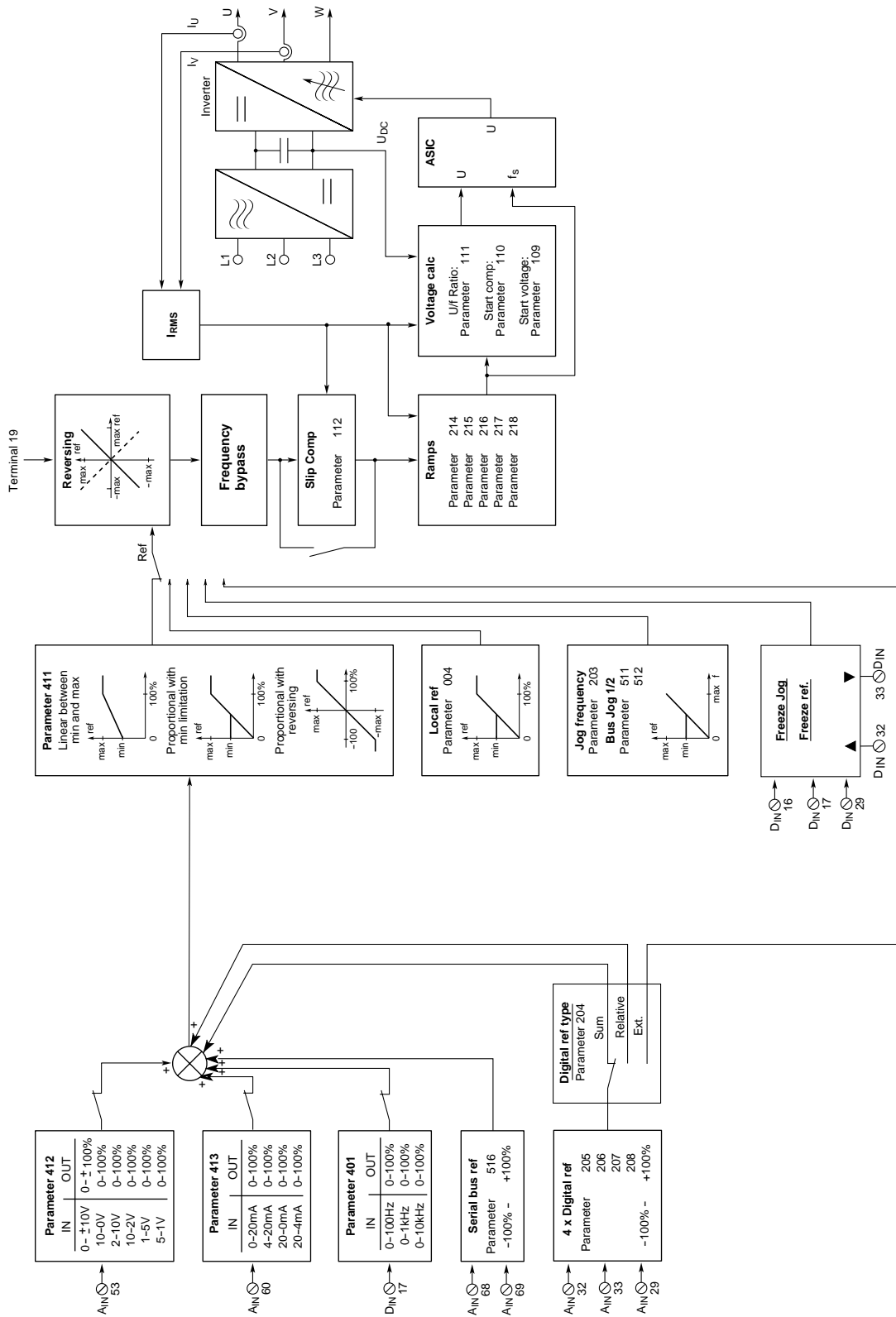

Speed Control Signal -- Closed Loop

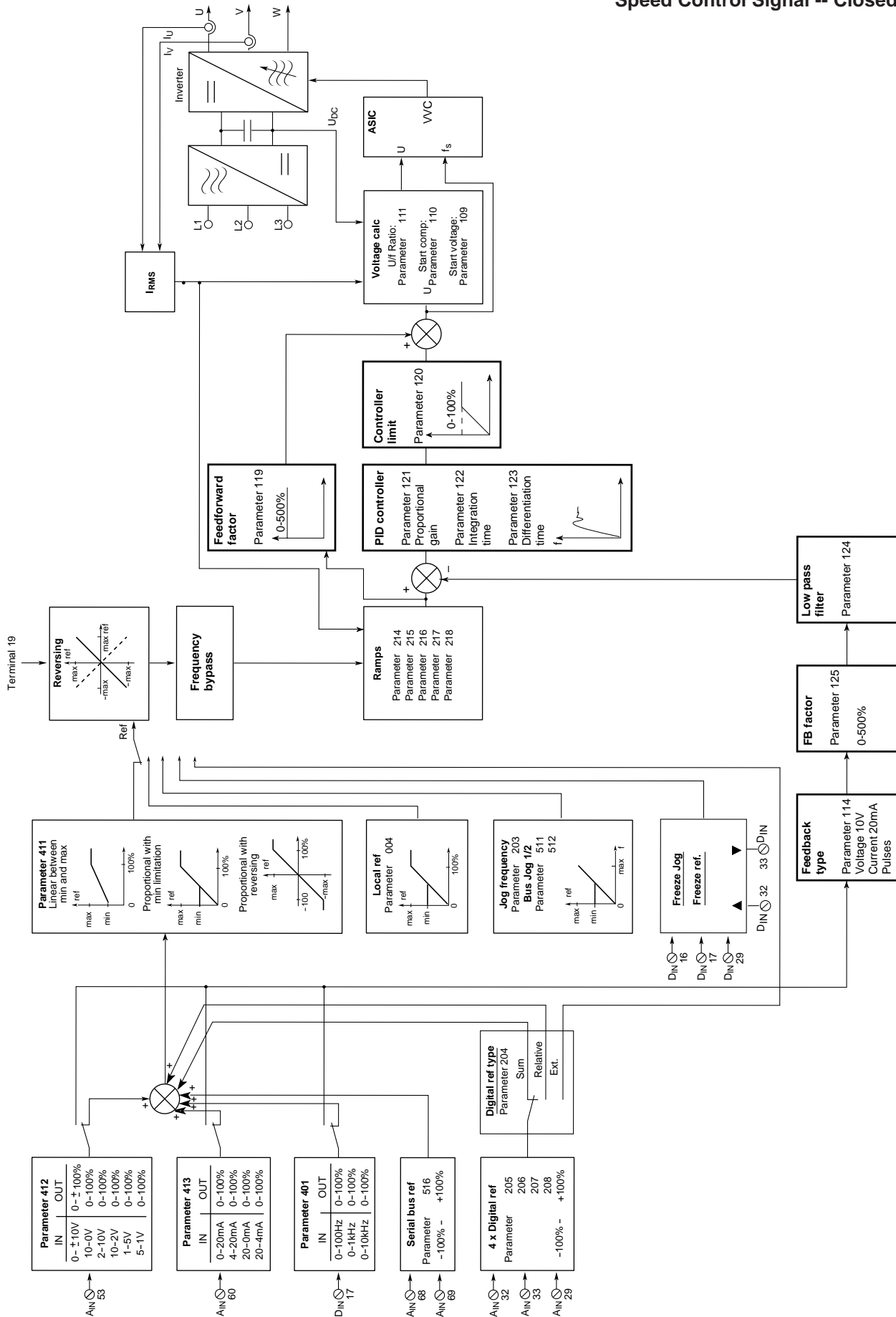

Parameter Groups

Group 0 -- Operation and Display

Group 0 includes parameters that pertain to display readouts, local operation and the handling of setups.

Group 0 parameters are:

| | |
|--------------------------|-----------------------------|
| 000 Language Select | 008 Local Loc/Hand (En/Dis) |
| 001 Setup Selection | 009 Local Rem/Auto (En/Dis) |
| 002 Setup Copy | 010 Local Ref (En/Dis) |
| 003 Local/Remote (HOA) | 011 Reset kWh Counter |
| 004 Local Reference | 012 Reset Time Counter |
| 005 User Read-Out at Max | 014 Power-up Mode |
| 006 Local Reset (En/Dis) | 015 Setup Program |
| 007 Local Stop (En/Dis) | |

Group 1 -- Load and Motor

Group 1 includes parameters that tune the drive to the application and the motor. Many of the special features of the VLT 3500 Series drive are included in Group 1. One of these is the “Automatic Energy Optimizer” (AEO), which, if enabled, monitors the load characteristics during operation and, if possible, reduces voltage to increase efficiency. In addition, programming the correct variable torque load characteristics is done in Group 1. The VLT 3500 Series has an integral controller with feed-forward function. It is programmed in Group 1.

Group 1 parameters are:

| | |
|------------------------------|------------------------------|
| 100 Load Type (4) | 116 Display @ Max Fdbk |
| 101 Speed Control (Fdbk) (4) | 117 Display Unit |
| 102 Current Limit Control | 119 Feed Forward Factor (4) |
| 103 Motor Power (kW) (4) | 120 Controller Range (4) |
| 104 Motor Voltage (4) | 121 Proportional Gain (4) |
| 105 Motor Frequency (4) | 122 Integral Time (4) |
| 107 Motor Current (4) | 123 Differentiation Time (4) |
| 109 Starting Voltage (4) | 124 Low Pass Filter (4) |
| 114 Feedback Type | 125 Feedback Factor (4) |
| 115 Display @ Min Fdbk | |

Group 2 -- References and Limits

Group 2 includes parameters that establish operating conditions and limits for the drive.

Group 2 parameters are:

| | |
|---------------------------------|--------------------------------|
| 201 Min. Freq. (Follower) (4) | 214 Ramp Type (4) |
| 202 Max. Freq. (Follower) (4) | 215 Ramp-up Time (4) |
| 203 Jog Freq. (4) | 216 Ramp-down Time (4) |
| 204 Dig. Ref. Type (Effect) (4) | 217 Alt. Ramp-up Time (4) |
| 205 Dig. Ref. 1 (%) (4) | 218 Alt. Ramp-down Time (4) |
| 206 Dig. Ref. 2 (%) (4) | 219 Freq. Bypass 1 (4) |
| 207 Dig. Ref. 3 (%) (4) | 220 Freq. Bypass 2 (4) |
| 208 Dig. Ref. 4 (%) (4) | 221 Freq. Bypass 3 (4) |
| 209 Current Limit (A) (4) | 222 Freq. Bypass 4 (4) |
| 210 Warn. Freq. Low (4) | 223 Freq. Bypass Wdth % (4) |
| 211 Warn. Freq. High (4) | 224 Carrier Freq. (4) |
| 212 Warn. Curr. Low (4) | 225 Variable Carrier Freq. (4) |
| 213 Warn. Curr. High (4) | 232 Idle Running Current (4) |

Group 3 -- Functions and Timers

Group 3 includes parameters that establish stop/start conditions and time delays for the drive.

Group 3 parameters are:

| | |
|------------------------------|-------------------------------|
| 301 Start Freq. (4) | 310 Trip Delay, Current Limit |
| 302 Start Delay (4) | 311 Trip Delay, Inv. Fault |
| 303 High Starting Torque (4) | 312 Max Auto Restart Time |
| 304 Mains Failure (Stop) | 313 Motor Check (4) |
| 305 Flying Start (4) | 314 Motor Preheat (4) |
| 306 DC Braking Time (4) | 315 Motor Therm. Protect (4) |
| 308 DC Brake Voltage (4) | 316 Relay 1 ON Delay |
| 309 Reset mode (Counts) | 317 Relay 1 OFF Delay |

Group 4 -- Inputs and Outputs

Group 4 includes parameters that allow the drive to respond to inputs and send outputs to other devices.

Group 4 parameters are:

| | |
|----------------------------|----------------------------|
| 400 Binary Input 16 | 409 Relay Output 01 |
| 401 Binary Input 17 | 410 Relay Output 04 (4) |
| 402 Binary Input 18 | 411 Analog Ref. Type (4) |
| 403 Binary Input 19 | 412 Term. 53 Input Voltage |
| 404 Binary Input 27 (Stop) | 413 Term. 54 Input Voltage |
| 405 Binary Input 29 | 414 Time Out |
| 406 Binary Input 32/33 | 415 Time Out Function |
| 407 Signal Output 42 (4) | 420 Ext. Hand Ref. Type |
| 408 Signal Output 45 | |

Group 5 -- Serial Communication

Group 5 includes parameters that allow the drive to respond to serial communication.

Group 5 parameters are:

| | |
|------------------|--------------------------|
| 500 Address | 509 Setup Select |
| 501 Baud Rate | 510 Digital Speed Select |
| 502 Data Readout | 511 Bus Jogging 1 |
| 503 Coasting | 512 Bus Jogging 2 |
| 504 Q-stop | 513 Catch Up Value |
| 505 DC Brake | 514 Bus Bit 4 |
| 506 Start | 515 Bus Bit 11/12 |
| 507 Direction | 516 Bus Reference |
| 508 Reset | 517 Store Data Values |

Group 6 -- Service and Diagnostics

Group 6 includes parameters that help diagnose operation and service problems.

Group 6 parameters are:

| | |
|--------------------|-----------------------------|
| 600 Operation Data | 604 Operation Mode |
| 601 Data Log | 605 Personal Display Select |
| 602 Fault Memory | 606 Display Mode |
| 603 Type Plate | 650 VLT Type |

(4) This parameter can be set differently in each of the four parameter sets.

Programming

Below is the detail for all the parameters for all of the groups. You may view the present setting and change the setting by using the key pad on the drive. Many parameters can also be read and changed using the computer-based VLS-DIALOG program. The following description assumes that the key pad is being used, but the parameters and their function are the same either way.

Before changing any parameter, it is recommended that you write down the present setting. This will allow resetting the parameter if the change does not result in the desired performance.

To enter the extended menus to change a parameter:

1. Press "Menu" and "+" simultaneously.
2. Press "+" or "-" to move to desired group.
3. Press "Menu" to allow access to the items in the group.
4. Press "+" or "-" to move to the desired item and view the present value for that item.
5. Press "Data" to access the bottom line of the display to allow changing the present selection.
6. Press "+" or "-" to scroll through the possible values.
7. Press "Menu" and "Data" simultaneously to leave the programming mode.

Group 0 -- Operation and Display

000 Language (LANGUAGE)

| | |
|---------------------|-----|
| Value: | |
| ★ English (ENGLISH) | [0] |
| German (DEUTSCH) | [1] |
| French (FRANCAIS) | [2] |
| Danish (DANSK) | [3] |
| Spanish (ESPANOL) | [4] |
| Italian (ITALIANO) | [5] |

Function and Description of choice:

Determines the language of the display. This can also be chosen from Quick Set Up step 0.

001 Setup Choice, Operation (SETUP OPER)

| | |
|------------------------------|-----|
| Value: | |
| Pre-programmed (FACTORY SET) | [0] |
| ★ Setup 1 (SETUP 1) | [1] |
| Setup 2 (SETUP 2) | [2] |
| Setup 3 (SETUP 3) | [3] |
| Setup 4 (SETUP 4) | [4] |
| Multi-setup (MULTI SETUP) | [5] |

Function:

This parameter chooses the setup number you want to control the drive.

Description of choice:

Pre-programmed [0] contains the default parameters. The parameters in this setup cannot be changed. It can be used to restore the default parameters to one or more of the numbered setups. Use parameter 002 to copy these defaults to one or more of the numbered setups.

Setups 1-4 [1]-[4] are four individual setups for use as desired. Changes can only be made to the setup specified in parameter 015. By default, this is the currently active setup, which is specified here. Changes made to the active setup take effect immediately. Certain parameters require that the drive be stopped before any change can be made. The third line of the display will indicate this.

Multi setup [5] is used if remote switching from one setup to another is required. The parameters that can be different from one setup to another are shown in the general description of the groups. If you want to change from one setup to another remotely, choose "Multi-setup" and use terminals 16/17 or 32/33, or the serial port to make the change. See parameter 400, 401 and 406.

002 Copy of Setups (MENU SET C)

| | |
|------------------------------------|-----|
| Value | |
| ★ No copying (DO NOT COPY) | [0] |
| Copy to 1 from # (COPY TO 1 FRO) | [1] |
| Copy to 2 from # (COPY TO 2 FRO) | [2] |
| Copy to 3 from # (COPY TO 3 FRO) | [3] |
| Copy to 4 from # (COPY TO 4 FRO) | [4] |
| Copy to ALL from # (COPY ALL FROM) | [5] |

Function:

A menu setup can be copied to one of the other setups or to all the other setups simultaneously, although not to setup [0]. Only the setup chosen in parameter 015 can be used as the source for the copying.

Copying is only enabled in Stop mode.

Description of choice:

The copying starts when you have entered the desired copying function and Data mode is left by pressing the "Menu" key, or after 20 seconds of no activity. Line 3 in the display flashes while copying is in progress. The display indicates the destination setup and the source setup. The source is always the setup specified in parameter 15. When copying has been completed, the data value shifts automatically to *No copying* [0].

★ = ROM default setting. ✓ = Normal Danfoss setup. Text in () = display text. Figures in [] are used when communicating with the bus.

003 Local/Remote Control (HAND-O-AUT)

Value:

- ★ Use keypad (KEYPAD HOA) [0]
- ✓ Use keypad with external stop (KEY HOA w. stp) [1]
- External HOA (EXTERNAL HOA) [2]

Function:

There is a choice of three different Local/Remote control modes for controlling the drive. Use *External H-O-A* when remote switching between “Hand” (manual operation) and “Auto” (control via general control system) is to be used. If *External H-O-A* is chosen, the “Local/Hand” key cannot be used directly on the control panel of the drive.

Description of choice:

If *Use keypad* [0] is selected, the speed can be controlled directly on the control panel of the drive by activating the “Local/Hand” key. The “Stop” key is active on the control panel of the drive, unless it has been defeated by parameter 007. When shifting between “Local/Hand” and “Remote/Auto”, the local speed reference will not be saved.

If *Use keypad with external stop* [1] is selected, the drive can be stopped by breaking the connection between terminal 12 (24 V DC) and terminal 27. Terminal 27 must be programmed for *Coast stop* [0] or *Reset and Coast Stop* [3] in parameter 404.

If *External H-O-A* [2] is selected, it is possible to change between “Hand” (manual operation) and “Auto” (control from general control system) via the control terminals of the drive, as programmed in parameters 400 through 403. “Latch Start Hand” is programmed in parameter 403 or 405. The reference type for “Hand” control is selected in parameter 420.

004 Local Reference (LOCAL SPEE)

Value:

00.00 to f_{MAX}

Function:

A local reference can be programmed in parameter 004. If the programmed local reference is to be active, the “Local/Hand” key must have been pressed. To ensure smooth operation, each time the drive is placed into “Local/Hand” from the “Remote/Auto” mode, the local speed reference is reset to match the drive’s present speed. The local speed reference is retained after the “Stop” key is pressed, as long as the drive stays in the “Local/Hand” mode.

Description of choice:

The speed can be set directly in Hz. The set value is saved after 20 seconds. The setting is saved even after power is removed, but it is not saved when the drive is switched to “Remote/Auto” mode. The local reference cannot be controlled via serial communication. Data changes in parameter 004 are blocked if parameter 010 is programmed as DISABLE.

★ = ROM default setting. ✓ = Normal Danfoss setup. Text in () = display text. Figures in [] are used when communicating with the bus.

!WARNING

The motor may start without warning if parameter 014 is changed to Auto restart [0] and a value is entered into parameter 004.

005 User Readout (VALUE AT M)

Value:

1 to 9999 ★ 100

Function:

Select the desired maximum value of the unit chosen by parameter 117. This will typically be “100” for % speed, “1750” for RPM, etc. Parameter 101 must be set to “Open Loop” to access this function.

Description of choice:

The programmed value will be displayed when the output frequency is equal to f_{MAX} (parameter 202).

006 Local Reset (LOCAL RESE)

Value:

- Not possible (DISABLE) [0]
- ★ Possible (ENABLE) [1]

Function:

Allows, or prevents, faults from being reset from the key pad.

007 Local Stop (LOCAL STOP)

Value:

- Not possible (DISABLE) [0]
- ★ Possible (ENABLE) [1]

Function:

Allows, or prevents, the drive from being stopped from the key pad.

008 Local/Hand (KEY LOCAL/)

Value:

- Not possible (DISABLE) [0]
- ★ Possible (ENABLE) [1]

Function:

Allows, or prevents, the drive from being switched to “Local/Hand” mode from the key pad.

009 Remote/Auto (KEY REMOT/)

Value:

- Disable (DISABLE) [0]
- ★ Enable (ENABLE) [1]

Function:

Allows, or prevents, the drive from being switched to the "Remote/Auto" mode from the keypad.

010 Local Speed Selection (LOC REFERE)

Value:

- Disable (DISABLE) [0]
- ★ Enable (ENABLE) [1]

Function:

The ability to change the local speed reference via parameter 004 can be enabled or disabled.

Description of choice:

If *disable* [0] is selected in parameter 010, the local speed reference cannot be changed via parameter 004.

011 Reset of kWh (ENERGY COU)

Value:

- ★ No reset (NO RESET)
- Reset (RESET)

Function:

Zeroing of kW energy counter.

Description of choice:

Reset is initiated when RESET has been selected and the Data mode is exited. Cannot be selected via the serial bus. CAUTION When RESET has been selected, zeroing has been completed.

012 Reset of Hours Run (HOUR COUNT)

Value:

- ★ No reset (NO RESET)
- Reset (RESET)

Function:

Resets the hour meter to zero. (See also parameter 600). The hour meter functions only when a start command has been given.

Description of choice:

Reset starts when Data mode is exited. The hour meter cannot be reset via the serial bus.

014 Power Up Mode (POWER-UP M)

Value:

- ✓ Auto restart in local operation, using saved reference speed (AUTO RESTART) [0]
- ★ Stopped in local operation, using saved reference speed (LOC=STOP) [1]
- Stopped in local operation, set speed reference to 0 (LOC=STP+REF=0) [2]

Function:

When the "Local/Hand" key has been activated and the drive is running with local speed reference, or if FREEZE REFERENCE is used, it is possible to program the state in which the drive is to start up after AC power has been lost and restored.

Description of choice:

Auto restart in local operation, use saved reference speed [0] is selected if the unit is to start up with the local speed reference that was in force when AC power was lost.

Stopped in local operation, use saved reference [1] is selected if the unit is to remain stopped when the AC line is restored. After the "Start" key is pressed, the saved, local speed reference is used.

Stopped in local operation, set speed reference to 0 [2] is selected if the unit is to remain stopped when the AC line is connected. Local Reference (parameter 004) and Freeze Reference (parameter 400, 401 or 405) are reset to 0.

If remote operation is used with a Freeze Reference function the Freeze Reference will be reset to 0 when the AC power is removed and restored. Use parameter 406 to retain the Freeze Reference speed through a power outage.



NOTE:

In remote-controlled operation, the restart function is always an "Auto Restart". If the unit is to remain stopped after power is restored, select Pulse Start in parameter 402.

015 Setup Choice, Programming

(SETUP PROG)

Value:

| | | |
|-----------------------|---------------|-----|
| Pre-programmed | (FACTORY SET) | [0] |
| Setup 1 | (SETUP 1) | [1] |
| Setup 2 | (SETUP 2) | [2] |
| Setup 3 | (SETUP 3) | [3] |
| Setup 4 | (SETUP 4) | [4] |
| ★ Setup=Parameter 001 | (SETUP=P001) | [5] |

Function:

It is possible to choose the setup that will be affected by parameter changes. The four menu setups can be programmed independently of the setup in which the drive is running (selected in parameter 001). This also determines the parameter set that is used as the source when copying setups (parameter 002).

Description of choice:

Pre-programmed [0] contains the factory-set data and can be used as a source for data. The language is always English. It is not possible to change data when running from this setup.

Setups 1-4 [1]-[4] are four individual setups which can be used as desired. They can be programmed independently of the setup currently used.

Setup = Parameter 001 [5] is the pre-selected value normally used. With this choice, parameter changes will take effect immediately because they affect the active set.



NOTE:

If the setup being used is changed, the changes will take effect immediately.

Group 1 -- Load and Motors

100 Load (LOAD TYPE)

Value:

| | |
|----------------------------------------------------------------------------|------|
| Variable torque low (VT MODE-LOW) | [0] |
| Variable torque medium (VT MODE-MED) | [1] |
| Variable torque high (VT MODE-HIGH) | [2] |
| Variable torque low with constant torque start (VT LOW W/CT) | [3] |
| Variable torque, medium, with constant torque start (VT MED W/CT) | [4] |
| Variable torque, high, with constant torque start (VT HIGH W/CT) | [5] |
| No operation (NO OPERATION) | [6] |
| No operation (NO OPERATION) | [7] |
| No operation (NO OPERATION) | [8] |
| Variable torque with AEO function and constant torque start (ENERGY CT.ST) | [9] |
| ★ Variable torque, low, with AEO (ENERGY VT.L)* | [10] |
| Variable torque, medium, w/AEO (ENERGY VT.M)* | [11] |
| ✓ Variable torque, high, with AEO (ENERGY VT.H)* | [12] |

Function:

This parameter allows the drive's V/Hz pattern to be tailored to the requirements of the load. Low V/Hz means reduced energy consumption and less motor noise. Too low a V/Hz pattern results in poor speed regulation or the inability to start the load.

With the factory setting [10], the AEO function (Automatic Energy Optimizing) is active. This means that the drive automatically adjusts the voltage to the present load from the pump or fan motor. This ensures optimum efficiency and minimum motor noise. The AEO function is active above 20% of f_{MAX} (parameter 202).

Description of choice:

Variable torque (VT) low [0], *medium* [1] or *high* [2] is chosen if the motor torque load is proportional to the square of the speed (centrifugal pumps and fans). The choice of torque characteristic should be made taking into account the need for trouble-free operation, minimum energy consumption and the lowest possible acoustic noise level.

Variable torque (VT) low [3], *medium* [4] or *high* [5] with *constant torque (CT) start* is selected if there is a need for a greater breakaway torque than that available with variable torque start. The curve for constant torque is followed until the speed reference is reached. Variable torque operation is provided after that. The magnitude of the starting voltage is controlled by parameter 109.

Variable torque with AEO function and constant torque start [9] is selected if the variable torque characteristic is unknown and there is a need for a high breakaway torque.

When the desired speed reference has been reached, the AEO function will adjust the voltage to the optimum value, which minimizes motor noise and maximizes efficiency.

Variable torque low [10], *medium* [11] and *high* [12] with AEO is selected when the starting torque is relatively low. The AEO function is active; it adjusts the voltage to the load which minimizes motor noise and maximizes efficiency.

* There is only one AEO curve available for the VLT Type 3575-3800, and for the 208/230 V VLT Type 3542-3562. Parameters [10], [11] and [12] all select the AEO VT LOW curve.



NOTE:

When multiple motors will be run at once, it is not advisable to use the AEO function.

101 Speed Control (SPEED CONT)

Value:

| | |
|---------------------------|-----|
| ★ Open loop (OPEN LOOP) | [0] |
| Closed loop (CLOSED LOOP) | [2] |

Function:

It is possible to choose two different kinds of speed control: *Open loop* and *closed loop*.

Description of choice:

Open loop [0] is chosen if normal control is desired.

Closed loop [2] is chosen if operation with process feedback is required. The closed loop PID controller must be set up through parameter 119 to 125.

★ = ROM default setting. ✓ = Normal Danfoss setup. Text in () = display text. Figures in [] are used when communicating with the bus.

102 Setting of Current Limit (SET CUR.LI)

Value:

- ★ Pre-programmed value (PROGRAM.VALUE) [0]
- Voltage signal (10VDC SIGNAL) [1]
- Current signal (20 mA SIGNAL) [2]

Function:

Although not commonly done in HVAC applications, speed can be controlled by means of the current limit, which allows indirect control of the torque. The current limit is set in parameter 209, or by means of a current or voltage signal in parameter 412 or parameter 413.

Description of choice:

Pre-programmed value [0] is chosen if a fixed, set limit for the current limit is desired. This is the normal method of operation. The current limit is set in parameter 209.

Voltage signal [1] is selected if the current limit is to be adjustable during operation by means of a 0 to 10 V analog signal on analog input 53 (parameter 412). 0 V will correspond to 0% current, and 10 V will correspond to the value in parameter 209.

Current signal [2] is selected if the current limit is to be adjustable during operation by means of a 0 to 20 mA analog signal on analog input 60 (parameter 413). 0 mA will correspond to 0% current limit, and 20 mA will correspond to the value of parameter 209.



NOTE:

Both a start command and a speed reference command must be provided to run with current limit control.

⚠ DANGER

If an analog signal is used to set current limit, the motor may rotate for up to five seconds when the drive is turned on, even if the current limit setting is 0.

103 Motor Power (MOTOR POWE)

Value:

- Depends on unit*
- Small size (in kW) [0]
- Middle size (in kW) [1]
- Larger size (in kW) [2]

Function:

This parameter allows a choice of the kW value that best matches the rated motor power.

The factory setting will be for the nominal kW equivalent of the horsepower size on the drive nameplate.

Description of choice:

Check the rated motor power on the motor nameplate. If it is not equal to the nominal horsepower rating on the drive nameplate, select the most appropriate size. (1 HP = 0.746 kW)

104 Motor Voltage (U_{M,N})(MOTOR VOLT)

Value:

- Only 200-230 V units*
- ★ 200 V [0]
- ✓ 208/220 V [1]
- 230 V [2]
- Only 380-415 V units*
- ★ 380 V [3]
- 400 V [4]
- 415 V [5]
- 440 V [6]
- Only 440-500 V units*
- 440 V [6]
- ★ 460 V [7]
- 500 V [8]

Function:

The rated voltage that most closely matches the motor nameplate voltage can be selected.

Description of choice:

Parameter 107 and 109 are changed automatically. All values can be addressed via the bus.

If VLT Type 3575-3800 drives do not show the required lower voltages, make this selection through parameter 650. This is also chosen Quick Set Up Menu step 1.

★ = ROM default setting. ✓ = Normal Danfoss setup. Text in () = display text. Figures in [] are used when communicating with the bus.

105 Motor Frequency (f_N)(MOTOR FREQ)

Value:

- 50 Hz (50 Hz) [0]
- ✓ 60 Hz (60 Hz) [1]
- 87 Hz (87 Hz) [2]
- 100 Hz (100 Hz) [3]
- ★ Depends on unit

Function:

Choose the frequency that corresponds to the rated motor frequency.

Description of choice:

Consult factory before selecting a motor frequency other than the rated motor frequency. This is also chosen in Quick Set Up Menu step 3.

107 Motor Current (MOTOR CURR)

Value:

Full load amps from motor nameplate

Function:

It is important to specify the rated motor current because it is used in part to calculate torque and thermal motor protection, (ETR),

Description of choice:

The rated motor current, which can be seen from the motor nameplate, must be entered. This is also chosen in Quick Set Up Menu step 2.

109 Start Voltage (START VOLT)

Value:

0.0 to (U_{M,N} + 10%)

Function:

When *Constant torque start* (CT) has been chosen in parameter 100, the start voltage can be adjusted. By increasing the start voltage, a high start torque can be obtained. Small motors (<1 HP) normally require a high start voltage. When motors are connected in parallel, it may be desirable to increase the starting voltage. When constant torque start is not selected, this value has no effect on the operation of the drive.

Description of choice:

The lowest possible value that provides reliable motor starting torque is desired.:

1. Select a value that enables starting with the given load.
2. Reduce this value until starting up with the given load is barely possible, then increase slightly.
U_{M,N} = rated motor voltage.

⚠WARNING

If the start voltage is set too high, the motor may overheat or the drive may fault trip. Do not set any higher than required for reliable starting.

114 Feedback Signal (FEEDBACK T)

Value:

- Voltage (VOLTAGE) [0]
- ★ Current (CURRENT) [1]
- Pulses (PULSES) [2]

Function:

This parameter allows a choice of process feedback signal in a closed loop system, as chosen in parameter 101. It has no effect if parameter 101 is set to OPEN LOOP. For further information, see the section on the PID controller.

Description of choice:

If a PID controller is used, one of the inputs on terminal 17 (parameter 401), terminal 53 (parameter 412) or terminal 60 (parameter 413) must be used for the feedback signal. The same type of signal cannot be the reference signal.

★ = ROM default setting. ✓ = Normal Danfoss setup. Text in () = display text. Figures in [] are used when communicating with the bus.

115 Display Value at Minimum Feedback

(DIS VLU@mi)

Value:

0 to 9999 ★ 0

Function:

Parameters 115 and 116 are used to scale a display read-out which is proportional to a feedback transmitter signal. The value is displayed if feedback has been selected in Display mode.

Description of choice:

If a transmitter, for example, has a range of 2 to 10 in wg, 2 can be programmed in parameter 115 and 10 in parameter 116. In parameter 117 the unit, in wg, [23], is chosen.

116 Display Value at Maximum Feedback

(DIS VLU@ma)

Value:

0 to 9999 ★ 100

Function & Description of choice:

Same as parameter 115, except sets the maximum..

117 Display Unit (DISPLAY UN)

Value:

| | | | |
|----------------------|------|-----------------------|------|
| ★ % | [0] | °F | [21] |
| °C | [1] | PPM | [22] |
| PPM | [2] | in wg | [23] |
| Pa | [3] | bar | [24] |
| bar | [4] | RPM | [25] |
| RPM | [5] | gal/s | [26] |
| l/s. | [6] | ft ³ /s | [27] |
| m ³ /s. | [7] | gal/min. | [28] |
| l/min. | [8] | ft ³ /min. | [29] |
| m ³ /min. | [9] | gal/h | [30] |
| l/h | [10] | ft ³ /h | [31] |
| m ³ /h | [11] | lb/s | [32] |
| kg/s. | [12] | lb/min. | [33] |
| kg/min. | [13] | lb/h | [34] |
| kg/h | [14] | t/min. | [35] |
| t/h | [15] | ft | [36] |
| m | [16] | lb ft | [37] |
| Nm | [17] | ft/s | [38] |
| m/s. | [18] | ft/min. | [39] |
| m/min. | [19] | mVs | [40] |
| (no unit) | [20] | lb/in ² | [41] |

Function:

Choose the values that are to be shown in the Display mode together with the feedback value. Scaling of the display readout is carried out in parameters 115 and 116.

Description of choice:

Sets the units to be scaled.

Parameters 119 through 125 are used only for PID control.

119 FF Factor (FEED FWD F)

Value:

0 to 500% ★ 100%

Function:

This parameter is used in connection with a PID controller. The FF function makes a large or small part of the reference signal (setpoint) bypass the PID controller. This means that the PID controller only affects part of the control signal. Any change of the setpoint will affect the motor rpm directly. This parameter can be used to tune and stabilize the system.

Description of choice:

The feed forward factor is selected if the desired reference signal (setpoint) does not lead to the right start frequency. See the section on the PID controller at the end of the parameter section.

★ = ROM default setting. ✓ = Normal Danfoss setup. Text in () = display text. Figures in [] are used when communicating with the bus.

120 Control Range (CONTRL RAN)

Value:

0 to 100% ★ 100%

Function:

The regulator range (bandwidth) limits the output from the PID controller as a % of f_{MAX} .

Description of choice:

A desired % value of f_{MAX} can be selected. If the regulator range is reduced, speed variations will become smaller during initial adjustment.

121 Proportional Gain (PROPRT/L G)

Value:

00.00 to 10.00 ★ 00.01

Function:

The proportional gain sets the amplification factor of the error (the difference between the feedback signal and the setpoint).

Description of choice:

Quick regulation is obtained at a high amplification, but if the amplification is too high, the process may become unstable due to overshoot.

122 Integral Time (INTEGRAL T)

Value:

OFF to 9999.99 sec. ★ OFF

Function:

The integral time determines how long the PID controller takes to correct the fault. The integral time results in a delay of the signal, and therefore has a dampening effect that will improve stability.

Description of choice:

Quick regulation is obtained through a short integral time. However, if this time is set too short, the process will become unstable. If the integral time is set long, regulation becomes unnecessarily slow. *Off* means that the function is inactive.

123 Differential Time (DIFFERENTL)

Value:

OFF to 10.00 sec. ★ OFF

Function:

Quick control is obtained by a short differentiation time. If this time is too short, the process may become unstable. When the differentiation time is set at 0 sec., the differential function is not active.

Description of choice:

In typical pump and fan systems, the differential function is not used.

124 Lowpass Filter (LOWPASS FI)

Value:

00.0 to 10.00 sec. ★ 00.0 sec.

Function:

The feedback signal is dampened by means of a lowpass filter with a time constant (τ) of 0-10 sec. When set for 00.0 seconds, the lowpass filter is deactivated.

Description of choice:

If a time constant (τ) is programmed to be 0.1 sec., the cut-off frequency for the lowpass filter will be $1/0.1 = 10$ Hz. The PID controller will then regulate a feedback signal which varies at a frequency of less than 10 Hz. If the feedback signal varies at a higher frequency than 10 Hz, the PID controller will not react.

125 Feedback Factor (FEEDBACK F)

Value:

0 to 500% ★ 100%

Function:

The feedback factor is used if the transmitter cannot be selected optimally for the scale range of the setpoint.

Description of choice:

A value can be programmed which scales the feedback signal to fit it to the desired setpoint. If 50% is used as setpoint, for example, and the feedback signal is only 25%, parameter 125 enables programming of 200%, which means that the feedback signal is recorded as 50% ($25\% \times 200\% = 50\%$).

★ = ROM default setting. ✓ = Normal Danfoss setup. Text in () = display text. Figures in [] are used when communicating with the bus.

Group 2 -- References and Limits

201 Minimum Frequency (f_{MIN}) (MIN FREQUE)

| | |
|--------------------|----------------------------------------------|
| Value: | |
| 00.00 to f_{MAX} | ★ 00.0 Hz ✓06.0 Hz fans ✓16.0 Hz pumps |

Function:

Choose the minimum frequency that corresponds to the minimum speed at which the motor is to run. The minimum frequency can never be higher than the maximum frequency, f_{MAX} .

Description of choice:

A value from 0.0 Hz to the max. frequency (f_{MAX}) selected in parameter 202 can be chosen. This is also chosen in Quick Set Up Menu step 6.

202 Maximum Frequency (f_{MAX}) (MAX FREQUE)

| | |
|---------------------|-------------------------------------|
| Value: | |
| f_{MIN} to 120 Hz | ★ depending on the unit ✓60.0 Hz |

Function:

Choose a maximum frequency that corresponds to the maximum speed at which the motor is to run. The maximum frequency can never be lower than the minimum frequency, f_{MIN} .

Description of choice:

A value from f_{MIN} to 120 Hz can be chosen. Consult factory before setting a maximum frequency greater than the rated frequency of the motor. This is also chosen in Quick Set Up Menu step 7.

203 Jog Frequency (JOG FREQUE)

| | |
|---------------|--------|
| Value: | |
| 0.0 to 120 Hz | ★10 Hz |

Function:

The jog frequency is the fixed output frequency at which the drive runs when the jog function is activated. A jog button is not provided on the 3500 Series, but the function is available by applying +24 V DC to terminal 29. See parameter 405.

Description of choice:

The jog frequency can be selected to be lower than f_{MIN} (parameter 201) and higher than f_{MAX} (parameter 202).

NOTE:
 When the jog function is activated, the drive will run at the jog speed (preset speed) regardless of the external speed reference signal. Be sure that the system can be operated at this speed whenever the jog function is activated.

204 Digital Reference Type (DIG. REF.)

| | |
|------------------------------------------|-----|
| Value: | |
| ★ Sum (SUM) | [0] |
| Relative (RELATIVE) | [1] |
| ✓ External on/off function (EXT. ON/OFF) | [2] |

Function:

It is possible to define how the internal digital references are to be added to the other references. There is a choice of *Sum* and *Relative*. Using the *External on/off function* switches between other references and the internal digital references.

Description of choice:

If *Sum* [0] is selected, the selected digital reference percentage is a percentage of f_{MAX} . This is added to the other references. For example, if $f_{MAX} = 60$ Hz and $f_{MIN} = 0$ Hz, the digital reference is 20% and the analog references are 40 Hz, the total reference is:

$$.2 \times 60 \text{ Hz} + 40 \text{ Hz} = 52 \text{ Hz.}$$

If *Relative* [1] is selected, the selected digital reference percentage is a percentage of the other speed references. This is added to the other speed references. For example, if $f_{MAX} = 60$ Hz, $f_{MIN} = 0$ Hz, the digital reference is 20%, and the analog references are 40 Hz, the total reference is:

$$.2 \times 40 \text{ Hz} + 40 \text{ Hz} = 48 \text{ Hz.}$$

If *External on/off* [2] is selected, switching can be carried out via terminal 29 (parameter 405) between the other references and one of the digital references, as a percentage of f_{MAX} .

NOTE:
 The sign only determines the direction of rotation if external on/off has been selected. Reversing via terminal 19 has no effect.

★ = ROM default setting. ✓ = Normal Danfoss setup. Text in () = display text. Figures in [] are used when communicating with the bus.

205 Digital Reference 1 (REF. 1 DIG)

Value:

 -100.00% to +100.00% ★ 0 %
 of f_{MAX} /analog reference

206 Digital Reference 2 (REF. 2 DIG)

Value:

 -100.00% - +100.00% ★ 0 %
 of f_{MAX} /analog reference

207 Digital Reference 3 (REF. 3 DIG)

Value:

 -100.00% - +100.00% ★ 0 %
 of f_{MAX} /analog reference

208 Digital Reference 4 (REF. 4 DIG)

Value:

 -100.00% - +100.00% ★ 0 %
 of f_{MAX} /analog reference

Function (parameter 205-208):

Four different, internal, digital references can be programmed in parameters 205 to 208. The internal digital references are stated as a percentage of the value f_{MAX} (parameter 202) or as a percentage of the analog reference. If a f_{MIN} (parameter 201) has been programmed, the internal, digital reference as a percentage is calculated from the difference between f_{MAX} and f_{MIN} , and then added to f_{MIN} .

Description of choice (parameters 205-208):

The desired, internal, digital reference is programmed as a percentage of f_{MAX} (parameter 202). Using terminals 32 and 33 as described in parameter 406, it is possible to choose between the four internal, digital references. See the table below.

| Terminal 33 | Terminal 32 | |
|-------------|-------------|---------------------|
| 0 | 0 | Digital reference 1 |
| 0 | 1 | Digital reference 2 |
| 1 | 0 | Digital reference 3 |
| 1 | 1 | Digital reference 4 |

NOTE:

The sign determines the direction of rotation.

209 Current Limit (I_{LIM}) (CURRENT LI)

Value:

 0.0 to $I_{VLT,MAX}$ ★ depending on the unit
 ✓ 110% of rated current

Function:

Use this parameter to set the maximum intermittent output current. If the current limit is exceeded, the output frequency is reduced until the current falls to below the current limit. The output frequency will not increase to the reference level until the current has fallen below the current limit.

Description of choice:

The value set at the factory corresponds to the rated continuous output current of the VLT 3500 Series. If the current limit is to be used as motor protection, the rated motor current must be programmed. Parameter 310 determines the length of time that the drive will run in current limit before an overcurrent fault. The load range between 100 and 110% can be programmed, but it is only intended for intermittent operation with a maximum of 110% for 60 seconds. The intermittent operating time will be extended as the load drops below 110%, and becomes unlimited at 100%.

210 Warning: Low Frequency (LO FREQ. W)

Value:

000.0 to 120.0 Hz ★ 000.0 Hz

Function:

Set the frequency at which the warning is to occur.

Description of choice:

If the output frequency falls below the frequency set (f_{LOW}), the display shows LO FREQ. WARN. Parameters 407 through 410 allow an external warning signal for low frequency.

217 Alternative Accel (ramp up) Time (ALT. UP RA)

Value:

0000.00 to 3600.00 sec. ★ depends on unit
 ✓ 60 sec fan
 ✓ 10 sec pump

Function:

This alternative ramp time is activated when the jog function is activated through terminal 29 (parameter 405) or the serial communication. No start signal needs to be given.

Description of choice:

The desired alternative accel time is programmed. This generally should be set to the same value as parameter 215. While parameter 215 can also be accessed through the Quick Set Up Menu, parameter 217 can only be accessed through the Extended Menu.

218 Alternative Decel (ramp down) Time (ALT. DOWN)

Value:

0000.00 - 3600.00 sec. ★ depends on unit
 ✓ 60 sec fan
 ✓ 10 sec pump

Function:

This alternative decel time is activated when a quick-stop is selected from terminal 27, parameter 404 or serial bus.

Description of choice:

The desired alternative decel time is programmed. This generally should be set to the same value as parameter 216. While parameter 216 can also be accessed through the Quick Set Up Menu, parameter 218 can only be accessed through the Extended Menu.

219 Frequency Bypass 1 (FREQ 1 BYP)

Value:

0 to 120 Hz ★ 120 Hz

220 Frequency Bypass 2 (FREQ 2 BYP)

Value:

0 to 120 Hz ★ 120 Hz

221 Frequency Bypass 3 (FREQ 3 BYP)

Value:

0 to 120 Hz ★ 120 Hz

222 Frequency Bypass 4 (FREQ 4 BYP)

Value:

0 to 120 Hz ★ 120 Hz

223 Frequency Bypass Bandwidth (BYPASS B.W)

Value:

0 to 100% ★ 0 %

Function: (Parameter 219 to 223)

Some systems must avoid certain output frequencies due to resonance in the driven equipment. Parameters 219 through 222 each allow a range of output frequencies to be bypassed. Parameter 223 sets the bandwidth of the frequency set in parameters 219 through 222 to be avoided. This is set as a percent of the bypass frequency.

Description of choice: (Parameter 219 to 223)

Enter the frequencies to be avoided in parameters 219 through 222. Enter one bandwidth percentage to be avoided in parameter 223. The actual avoidance range will be the bandwidth percentage for each avoidance frequency; half below the set frequency, and half above the set frequency.

224 Carrier Frequency (CARRIER FR)

Value:

2.0 to 14.0 kHz ★ 4.5 kHz
 ✓ 14.0 kHz*

Function:

The set value determines the carrier frequency of the inverter. Changing the carrier frequency may minimize acoustic noise from the motor. *VLT Types 3575 - 3800 and 208/230 volt VLT 3542 - 3562 cannot be set above 4.5 kHz.

Description of choice:

The carrier frequency may be adjusted while the motor is running to find the carrier frequency at which motor noise is the lowest.



NOTE:

Switching frequencies higher than 4.5 kHz lead to automatic derating unless Adjustable Switching Frequency Modulation (ASFM), parameter 225 is enabled.

★ = ROM default setting. ✓ = Normal Danfoss setup. Text in () = display text. Figures in [] are used when communicating with the bus.

225 Adjustable Switching Frequency Modulation

(ASFM) (VAR.CARR.FR)

Value:

- ★ OFF (DISABLE) [0]
- ✓ HIGH CARR @ LOW (ENABLE) [1]
- Low Carrier Frequency at Low Speed (const.carr.low) [2]

Function:

To minimize acoustical motor noise, a high carrier frequency can be chosen parameter 224. However, the output of the drive must be derated when the carrier frequency is above 4.5 kHz. This presents no problem at low speeds, since the variable torque load will also be low. Reducing the carrier frequency as the speed (and load) increases allows the drive to produce full output. At extremely low speeds, a high carrier frequency may produce too much motor voltage. Reducing carrier frequency at output speeds below 12 Hz can correct this problem.

Description of choice:

OFF maintains the carrier frequency set in parameter 224 at all output speeds.

HIGH CARR @ LOW (shown as ENABLE on some drives) sets the drive to use the carrier frequency set in parameter 224 from minimum speed up to 50% speed. From 50% speed to maximum speed, the drive's carrier frequency decreases linearly to 4.5 kHz. This provides minimum motor noise at low speed while eliminating the need to derate the drive at maximum speed.

Low Carrier Frequency at Low Speed provides smooth operation at extremely low output speeds by reducing the PWM carrier frequency. At output frequencies below 12 Hz, the PWM carrier frequency will automatically change to match the drive's operating speed and load, This choice is only available on 460 V AC VLT Types 3575 through 3800 and on 208/230 V AC VLT Types 3542 through 3562. Because extremely low output speeds are not used, this is generally not useful for variable torque applications.

232 Idle Running Current (NO LOAD CU)

Value:

0.0 to I_{LIM} ★ Depends on unit

Function:

This parameter allows setting a minimum motor current value (idle running current). This allows one of the signal relays to be activated when the motor does not use any more current than the idle running current.

This function can be used for monitoring whether the V- belt has broken.

I_{LIM} is the current limit programmed in parameter 209.

Description of choice:

Relay 01 or 04 is activated though the setting of parameter 409 or 410 when the motor current drops below the value set in this parameter and the drive is running at the maximum frequency set in parameter 202.



NOTE: For this feature to function, the drive must be able to run up to the maximum frequency set in parameter 202. If that may not be the case, use parameter 212, Warning Current Low, to perform this function.

Group 3 -- Functions and Timers
301 Start Frequency (START FREQ)

Value:

00.0 to 10 Hz ★ 0.0 Hz

Function:

It is possible to define an output frequency at which the motor is to start. This will be the initial operation speed when Start is pressed. The accel ramp will not be used to reach this frequency. Start frequency is separate from minimum speed.

Description of choice:

Program the initial frequency for the motor to run at when given a start command.

302 Delayed Start (START DELA)

Value:

0.0 to 1.0 sec. ★ 0.0 sec.

Function:

VLT 3500 Series starts at the start frequency (parameter 301) and begins to ramp up when the start delay has ended.

Description of choice:

Program the desired time delay before VLT 3500 Series starts to ramp up.

303 High Starting Torque (HI START T)

Value:

0.0 to 1.0 sec. ★ 0.0 sec.

Function:

High starting torque allows a current approximately two times the current limit of parameter 209 for the specified time after a start command is given.

Description of choice:

Insert the time required to give 200% starting current.

304 AC Line (POWER FAIL)

Value:

- | | |
|------------------------------------|-----|
| ★ Uncontrolled stop (NORM PWR DWN) | [0] |
| Ramp down 1 (RAMP DOWN) | [1] |
| Ramp down 2 (ALT. RAMP DWN) | [2] |

Function:

Select one of the three ramp-down functions to control the ramp-down in a power-out situation. The exact ramp-down will depend upon the speed and load at the time of the power outage. If the ramp-down time is short, a regenerative effect may keep up the DC voltage which means that it takes longer before the drive shuts off.

Description of choice:

Uncontrolled stop [0]:

The motor continues to run at the selected speed until the control voltage drops too low.

Ramp down 1 [1]:

The motor begins to ramp down immediately following the Decel Time set in parameter 216 (or Quick Set Up Menu step 9) until the control voltage drops too low.

Ramp down 2 [2]:

The motor begins to ramp down immediately following the Alternative Decel Time set in parameter 218.

305 Catch a Rotating Motor (FLYING STA)

Value:

- | | |
|-------------------------------------|-----|
| ★ Disable (NO FLY START) | [0] |
| ✓ OK - same direction (SAME DIRECT) | [1] |
| OK - both directions (BOTH DIRECT) | [2] |
| Stop before start (DC-BRAKE @STA) | [3] |

Function:

This parameter is used when a stopped drive may be starting into a rotating motor.

Description of choice:

No Fly Start [0]

Select if the motor will not be rotating when a start command is given. The drive will always attempt to accelerate the motor from low speed. If the motor is rotating at a significant speed, the drive may give an overcurrent trip.

OK - same direction [1]:

Select if motor may be rotating in same direction as drive direction.

OK - both directions [2]:

Select if motor may rotate in either direction.

Stop before start [3]:

Select if the motor is to be first stopped by DC braking and then ramped to speed. The DC braking time is set by parameter 306.

306 DC Braking Time (DC-BRAKE T)

Value:

0000.0 to 3600.0 sec. ★ 0000.0 sec.

307 DC Brake Cut-in Frequency (DC-BRK ON)

Value:

000.0 to 120.0 Hz ★ 1.0 Hz.

308 DC Brake Voltage (DC-BRK VOL)

Value:

0 to 50 V ★ Depends on unit

Function:

If the stator of an asynchronous motor is supplied with a DC current, a braking torque will result. The amount of braking torque depends upon the DC braking voltage set by parameter 308.

Description of choice:

Select the duration of the energized DC voltage in parameter 306. Select the output frequency at which DC braking is to start on ramp-down in parameter 307. Select the amount of DC braking voltage in parameter 308. Parameters 306 and 307 must be different from 0 to activate the DC braking. DC braking can also be activated through terminal 27, parameter 404. There is usually no requirement for braking in HVAC applications.

⚠WARNING

If the DC brake voltage value is too high or if it is applied for too long, the motor will be damaged by overheating. If DC braking is used, start with low voltage values and a short time duration.

309 Reset Function (RESET MODE)

Value:

- ★ Manual reset (MANUAL) [0]
- Automatic reset (AUTOMATIC X 1) [1]
- Automatic reset (AUTOMATIC X 2) [2]
- Automatic reset (AUTOMATIC X 3) [3]
- Automatic reset (AUTOMATIC X 4) [4]
- Automatic reset (AUTOMATIC X 5) [5]
- Automatic reset (AUTOMATIC X 6) [6]
- Automatic reset (AUTOMATIC X 7) [7]
- Automatic reset (AUTOMATIC X 8) [8]
- Automatic reset (AUTOMATIC X 9) [9]
- ✓ Automatic reset (AUTOMATIC X 10) [10]
- Start disabled (START INHIBIT) [11]

Function:

The VLT 3500 Series can be programmed for automatic fault reset. From one to ten automatic reset attempts may be selected by this parameter. The time delay between reset attempts may be from one to ten seconds. The time delay is chosen by parameter 312.

Description of choice:

Manual reset [0] can be accomplished through the serial bus, terminal 16, or from the operating panel.

Automatic reset [1-10]: The number of resets, between 1 and 10, can be selected. If resetting fails, it is because the drive is in TRIP LOCK mode, which can only be reset by removing and reapplying the AC power.

Start not possible [11] disables manual or automatic reset after a fault trip. This setting is available only in connection with serial communication, because restart is only possible from the serial bus.

⚠DANGER

When auto restart is permitted, the motor may start without warning.

310 Trip Delay at Current Limit (TRIP DLY@C)

Value:

| | |
|---------------------------|-------|
| 0 to 60 secs. or OFF (61) | ★ OFF |
| | ✓ sec |

Function:

When the drive goes into current limit, as set by parameter 209, this timer determines how long the drive will run in current limit before it fault trips. This is provided to prevent damaging a stalled or heavily overloaded motor.

Description of choice:

Select how long the drive is going to be able to run at the current limit, I_{LIM} , before tripping. OFF will allow the drive to run in current limit indefinitely.

311 Trip Delay at Inverter Fault (TRIP DLY@F)

Value:

| | |
|---------------|-------------------|
| 0 to 35 secs. | ★ Depends on unit |
| | ✓ sec |

Function:

This setting determine how long the drive will continue to run after an overvoltage or undervoltage condition is detected.

Description of choice:

Select how long the drive is to be able to run at over- or undervoltage before tripping.

312 Maximum Automatic Restart Time (AUTO RESTA)

Value:

| | |
|---------------|-----------|
| 0 to 10 secs. | ★ 5 secs. |
|---------------|-----------|

Function:

If auto reset has been selected in parameter 309, the time delay before each reset attempt can be set.

Description of choice:

The time between tripping and automatic reset is selected.

313 Motor Check (MOTOR CHEC)

Value:

| | |
|-------------|-----|
| ★ Off (OFF) | [0] |
| On (ON) | [1] |

Function:

VLT 3500 Series is able to check whether a motor has been connected.

Description of choice:

If *On* [1] has been selected, the control checks that a motor is connected when there is 24 V on terminal 27 and no start command has been given. If no motor is detected, NO MOTOR is displayed.

This function is not available in VLT 3575 - 3800 Series and 208/230 volt VLT 3542 - 3562 Series.

314 Motor Preheat (MOTOR PRE)

Value:

| | |
|-------------|-----|
| ★ Off (OFF) | [0] |
| On (ON) | [1] |

Function:

The preheat function can be activated to lower the humidity level in the motor.

Description of choice:

If *On* [1] has been selected, the motor is preheated by means of direct current (approximately half the start voltage) when there is 24 V on terminal 27 and no start command has been given.

This function is not available in VLT 3575 - 3800 Series and 208/230 volt VLT 3542 - 3562 Series.

315 Motor Thermal Protection (MOTOR THER)

Value:

- Off (PROTECT-OFF) [0]
- Warning 1 (WARNING 1) [1]
- ★ Trip 1 (TRIP 1) [2]
- Warning 2 (WARNING 2) [3]
- Trip 2 (TRIP 2) [4]
- Warning 3 (WARNING 3) [5]
- Trip 3 (TRIP 3) [6]
- Warning 4 (WARNING 4) [7]
- Trip 4 (TRIP 4) [8]

Function:

The drive calculates whether the motor temperature exceeds the permissible limits. The calculation is based on 1.16 x rated motor current, as set in parameter 107. Four separate calculations are possible. One calculation can be chosen for each setup, or the same calculation can be used in several setups. Warning 1 and Trip 1 refer to the motor settings in setup 1, etc. It is possible to monitor the same motor in several setups, or up to four different motors can be monitored.

Description of choice:

Select *Off* (OFF) if no warning or tripping is required.

Select *Warning* if only a warning is to be displayed when the motor is overheated. The drive can be programmed to give an external warning through the signal outputs set by parameters 407 through 410.

Select *Trip* if a fault trip is desired when the motor is overheated. The drive can be programmed to give an external indication of the trip through the signal outputs set by parameters 407 through 410.

316 Relay ON Delay (RELAY ON D)

Value:

- 000.00 to 100.00 secs. ★ 000.00 secs.

Function:

Relay output 01, which is connected to terminals 01, 02, and 03 and controlled by parameter 409, can be programmed for a time delay. This has no effect on the operation of relay 04. No time delay for the operation of relay 04 is available.

Description of choice:

The setting of parameters 316 and 317 affects the duration of the time delay.

317 Relay OFF Delay (RELAY OFF)

Value:

- 000.00 to 100.00 secs. ★ 000.00 secs.
- ✓ 002.00 secs.

Function:

See parameter 316.

Description of choice:

See parameter 316.

Group 4 -- Inputs and Outputs

400 Terminal 16 Input (INPUT 16)

Value:

| | |
|-------------------------------------|-----|
| ★ Reset (RESET) | [0] |
| Stop (STOP) | [1] |
| Freeze reference (FREEZE REF.) | [2] |
| Selection of setup (SETUP SELECT) | [3] |
| Thermistor (THERMISTOR) | [4] |
| External H-O-A Hand (EXT. HOA HAND) | [5] |

Function:

Used for choosing between different possible functions of terminal 16.

Description of choice:

Reset [0]:

With 24 V DC from terminal 12 connected to terminal 16, the drive can be reset after tripping.

Stop [1]:

The stop function is activated by breaking 24 V DC from terminal 12 to terminal 16. Terminal 16 must have voltage for the motor to be able to run. Parameter 216 determines how the motor will stop. The function is normally used with Latch Start [1] set in parameter 402.

Freeze reference [2]:

Selected if terminals 32 and 33, set by parameter 406, are to be used for digital control of speed up/down (floating point control). 24 V DC from terminal 12 to terminal 16 will freeze the present reference. The speed can be changed by means of terminals 32 and 33. If used with an analog speed reference, when 24 v DC from terminal 12 is applied to terminal 16, the drive will “freeze” the present speed reference. Changes to the speed reference will have no effect on the drive’s operation until the voltage is removed from terminal 16.

Choice of setup [3]:

If Multi-setup [5] has been selected in parameter 001, terminal 16 allows a choice of Setup 1 (“0”) and Setup 2 (“1”). If more than 2 setups are required, both terminals 16 and 17 must be used for choosing the setup as shown below.

| Setup | Terminal 17 | Terminal 16 |
|-------|-------------|-------------|
| 1 | 0 | 0 |
| 2 | 0 | 1 |
| 3 | 1 | 0 |
| 4 | 1 | 1 |

Thermistor [4]:

Select if a thermistor or Klaxon thermal switch in the motor is to be able to stop the drive if the motor is overheated. The thermistor or thermal switch is to be connected between terminal 50 (+10 V) and terminal 16. When the resistance of the thermistor exceeds 3 kΩ or the Klaxon opens, the drive will trip and “MOTOR TRIP” will be displayed.

★ = ROM default setting. ✓ = Normal Danfoss setup. Text in () = display text. Figures in [] are used when communicating with the bus.

⚠ CAUTION

If the thermistor is selected in parameter 400, but no thermistor is connected, the drive will go into the Alarm mode. To reset, hold down the “Stop/Reset” key while changing the data values by means of the “+”/“-” keys.

External H-O-A Hand [5]:

Select if the H-O-A function is to be used externally from the drive for switching between manual operation (Hand) and normal remote control (Auto). By applying 24 V DC from terminal 12 to terminal 16, the hand mode is activated and adjustment of the output frequency by the reference chosen in parameter 420 is enabled. The drive will not start until a Pulse Start Hand is given via terminal 19 or terminal 29.

401 Terminal 17 Input (INPUT 17)

Value:

| | |
|------------------------------------|-----|
| Reset (RESET) | [0] |
| Stop (STOP) | [1] |
| ★ Freeze reference (FREEZE REF.) | [2] |
| Selection of setup (SETUP SELECT) | [3] |
| Pulse input 100 Hz (PULSES 100 Hz) | [4] |
| Pulse input 1 kHz (PULSES 1 KHz) | [5] |
| Pulse input 10 kHz (PULSES 10 KHz) | [6] |
| External H-O-A (EXT. HOA AUTO) | [7] |

Function:

Used for choosing the function of terminal 17.

Description of choice:

Reset, stop, freeze reference and choice of setup are similar to terminal 16.

Pulses:

Terminal 17 can be used for pulse signals in the ranges: 0 to 100 Hz, 0 to 1 kHz and 0 to 10 kHz. The pulse signal can be used as a speed reference in normal operation and as either a setpoint or a feedback signal for operation in closed loop or PID control. See parameter 101 if required. Pulse emitters with a PNP signal can be used between terminals 12 and 17. The common connection is to terminal 20.

External H-O-A [7]:

Select if the H-O-A function is to be used externally from the drive for switching between manual operation (Hand) and normal remote control (Auto). By applying 24 V DC from terminal 12 to terminal 17, the normal remote control mode is activated and normal control through the control terminals of the drive is enabled.

402 Terminal 18 (INPUT 18)

Value:

| | |
|--------------------------------|-----|
| ★ Start (START) | [0] |
| Latch start (LATCH START) | [1] |
| No operation (NO OPERATION) | [2] |
| External H-O-A (EXT. HOA AUTO) | [3] |

Function:

Used for choosing between different possible functions of terminal 18. Start and stop will be effected by the ramp times selected in parameters 215 and 216.

Description of choice:

Start [0]:

Selected if a start/stop function is desired. +24 V DC applied from terminal 12 to terminal 18 results in a start command. Removing the +24 V DC gives a stop command. This is a “2-wire” control. The drive will start or restart as soon as AC power is applied as long as it is in the Remote/Auto mode with no faults.

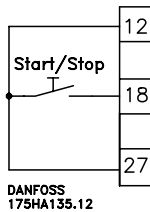

Latch start [1]:

Choose if a start and stop function is desired for two different inputs, one momentary input for start (terminal 18) and one for stop (terminal 16, 17 or 27). If terminal 18 is connected to the +24 V DC power source from terminal 12 for at least 20 msec., the drive will start. In the illustration at the right, if terminal 16 is disconnected from the +24 V DC power source from terminal 12 for at least 20 msec., the drive will stop. This is a “3-wire” control. The drive will not restart in remote mode after a power outage. This is not normally used for unattended HVAC applications.

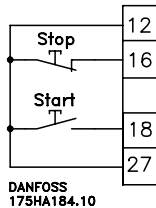

No operation [2]:

Select if the drive is not to react to signals coming to terminal 18.

If serial communication is used, the input status can be read and used by the master.

External H-O-A [3]:

Selected if the H-O-A function is to be used externally from the drive for switching between manual operation (Hand) and the normal remote control (Auto). By energizing 24 V DC from terminal 12 to terminal 17, the normal remote control mode is activated and normal control through the control terminals of the drive is possible.

403 Terminal 19 (INPUT 19)

Value:

| | |
|-------------------------------------|-----|
| ★ Reverse direction (REVERSING) | [0] |
| Start with reversing (START REV) | [1] |
| No operation (NO OPERATION) | [2] |
| External H-O-A Hand (EXT. HOA HAND) | [3] |
| Latch start hand (LATCH ST.HAND) | [4] |

Function:

Using this parameter, terminal 19 can be used for changing the direction of rotation of the motor, remotely switching to “Hand” operation, or starting using “3-wire control”.

NOTE:



It is not necessary to stop the drive to reverse the direction of the motor. If the drive is running when +24 V DC is applied to terminal 19, it will follow the ramp up and ramp down time settings to decelerate the motor to zero speed and then accelerate it in the reverse direction.

Description of choice:

Reversing [0]:

Choose if the ability to reverse the direction of rotation of the motor is desired. No signal on terminal 19 will set up the drive to run in the “forward” direction. 24 V DC from terminal 12 to terminal 19 will allow reverse rotation. To run in reverse, in addition to the reverse signal at terminal 19, a start command must be given to terminal 18.

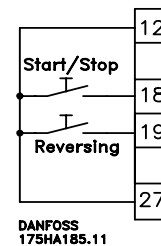

The reverse function will reverse the direction of the motor when its speed is controlled by the analog speed reference, the jog speed reference or from “Local/Hand” mode. It has no effect on rotation direction when using the digital references of parameters 205 through 208.

Start with reversing [1], parameter 402, Start [0]:

Select if start and reversing are to be activated at the same input. In effect, the switch to terminal 18 becomes a “start forward” switch and the switch to terminal 19 becomes a “start reverse” switch.

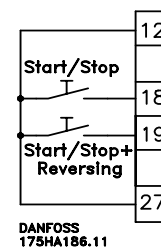

★ = ROM default setting. ✓ = Normal Danfoss setup. Text in () = display text. Figures in [] are used when communicating with the bus.

403 Terminal 19 (INPUT 19), continued

Start with reversing [1] and parameter 402 Latch Start [1]:
If a latch start has been selected in parameter 402, reverse will also latch start.

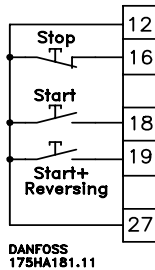

NOTE:

If 24 V DC is supplied from terminal 12 to terminals 18 and 19 at the same time, the motor will stop.

No operation [2]:
Same as parameter 402.

External H-O-A Hand [3]:
Select if the H-O-A function is to be used externally from the drive to switch between manual operation (Hand) and the normal remote control (Auto). By applying 24 V DC from terminal 12 to terminal 16, the manual operation mode is activated and the output frequency can be adjusted by the reference selected as external manual operation in parameter 420.

Latch Start Hand [4]:
Selected for starting the inverter when the drive is in the manual operation mode, "Hand". When 24 V DC is supplied from terminal 12 to terminal 19 for a minimum of 20 msec., start will be activated.

404 Terminal 27 Stop (INPUT 27)

Value:

- ★ Motor coasting stop (MTR. COAST) [0]
- Quick-stop (Q-STOP) [1]
- DC braking (DC-BRAKE) [2]
- Reset and motor coasting stop (RST&COAST) [3]
- Stop (STOP) [4]

Function:

Used to choose between different possible functions of terminal 27.



NOTE:

The motor is only able to run in remote mode if 24 V DC is supplied from terminal 12 to terminal 27. This can be overridden by using serial communication or local mode.



NOTE:

in order to allow the opening of the circuit to stop the drive in Local/Hand mode, parameter 003 must be set to KEY HOA w. stp and parameter must be set to either MTR. COAST or RST & COAST.

Description of choice:

Motor coasting stop [0]:
Choose if the motor is to coast to rest. When the connection from terminal 12 (24 V DC) to terminal 27 is broken, the motor will coast to a stop.

Quick-stop [1]:
Select if the motor is to be stopped using the alternative ramp time selected in parameter 218. When the connection from terminal 12, 24 V DC, to terminal 27 is broken, the motor will decelerate to a stop using the alternative deceleration time.

DC braking [2]:
Select if the motor is to be stopped using DC braking which is set up in parameters 306, 307 and 308. This function is only active when the values in parameters 306 and 308 are different from 0. When the connection from terminal 12 (24 V DC) to terminal 27 is broken, the motor will stop with DC braking.

Reset and coasting stop [3]:
Select if coast to stop and reset (see description of reset in parameters 400 and 401) are desired at the same time. When the connection from terminal 12 (24 V DC) to terminal 27 is broken, the motor will coast to stop and reset.

Stop [4]:
Choose if it is desired to stop the drive using the decel ramp as defined by parameter 216. When the connection from terminal 12 (24 V DC) to terminal 27 is broken, the drive decelerates to a stop as defined by parameter 216.

★ = ROM default setting. ✓ = Normal Danfoss setup. Text in () = display text. Figures in [] are used when communicating with the bus.

405 Terminal 29 Input (INPUT 29)

Value:

| | |
|---------------------------------------|-----|
| ★ Jogging (JOG) | [0] |
| Freeze jogging reference (JOG FREEZE) | [1] |
| Freeze reference (FREEZE REF) | [2] |
| Digital reference (DIGITAL REF) | [3] |
| Ramp selection (RAMP SELECT) | [4] |
| Latch start hand (LATCH ST.HAND) | [5] |

Function:

Use to choose the function of terminal 29.

Description of choice:

Jogging [0]:

Select to allow the drive to start and accelerate to the jog frequency defined in parameter 203 when terminal 12 (24 V DC) is connected to terminal 29. There is no need for a separate start command to activate jogging. The drive will accelerate to the jog speed using the alternative ramp-up time set in parameter 217. Jog has no effect during “Local/Hand” operation and it will not start the drive if the “Stop/Reset” key has been pressed.

Freeze jogging reference [1]:

Select if terminals 32 and 33 set by parameter 406 are to be used for digital control of speed up/down with the jogging speed as the point of reference. 24 V DC from terminal 12 supplied to terminal 29 will freeze the jogging reference. The speed can be changed by means of terminals 32 and 33.

Freeze reference [2]:

Selected if terminals 32 and 33, set by parameter 406, are to be used for digital control of speed up/down (floating point control). 24 V DC from terminal 12 to terminal 29 will freeze the present reference. The speed can be changed by means of terminals 32 and 33. If used with an analog speed reference, when 24 v DC from terminal 12 is applied to terminal 29, the drive will “freeze” the present speed reference. Changes to the speed reference will have no effect on the drive’s operation until the voltage is removed from terminal 29.

Digital reference [3]:

Select if there is to be a choice between one of the digital references, parameters 205 through 208 and other references, analog voltage (parameter 412), analog current (parameter 413), pulses (parameter 401), or bus references (parameter 516). Digital reference [3] is only active if *external on/off* has been selected in parameter 204. When the digital reference has been activated, the direction of rotation is determined exclusively by the sign of the speed reference value in parameter 205 through 208.

Choice of ramp [4]:

Different ramp times can be selected through terminal 29: If no voltage is applied to terminal 29, *Ramp 1* (from parameter 215 and 216) is used.

If 24 V DC from terminal 12 is supplied to terminal 29, *Ramp 2* (from parameter 217 and 218) is used. The selected ramp up/down times apply to start/stop through terminal 18 (or 19, if programmed) and apply if the reference is changed. Selection of *Quick-stop* [1] through terminal 27 automatically activates the alternative ramp down time, parameter 218.

Latch start Hand [5]:

Selected for starting the inverter when the drive is in manual operation mode, “Hand”. If 24 V DC is supplied from terminal 12 to terminal 29 for a minimum of 20 msec., start is activated.

406 Terminals 32/33 Input (INPUT 32/3)
Value:

- Choice of digital reference (SPEED SELECT) [0]
- ✓ Speed up/down (SPEED UP/DOWN) [1]
- Choice of setup (SETUP SELECT) [2]
- ★ 4 setups, extended (4 SETUP EXT.) [3]

Function:

Used to choose the functions of terminals 32 and 33.

Description of choice:
Selection of digital reference [0]:

Select if up to four different, pre-programmed, digital speed references (preset speeds) are to be chosen following the table below:

| Digital reference | Terminal 33 | Terminal 32 |
|-------------------|-------------|-------------|
| 1 (parameter 205) | 0 | 0 |
| 2 (parameter 206) | 0 | 1 |
| 3 (parameter 207) | 1 | 0 |
| 4 (parameter 208) | 1 | 1 |

Speed up/down [1]:

Select if digital control of the speed up/down is desired for floating point control. This function is active only if the freeze reference/freeze jogging reference has been selected in parameter 400, 401 or 405, and if the corresponding terminal 16, 17 or 29 is supplied with 24 V DC from terminal 12. As long as terminal 32 receives 24 V DC from terminal 12, the output frequency will increase towards f_{MAX} (set by parameter 202).

As long as terminal 33 receives 24 V DC from terminal 12, the output frequency will decrease towards f_{MIN} (set by parameter 201).

| | Terminal 33 | Terminal 32 |
|---------------------|-------------|-------------|
| No reference change | 0 | 0 |
| Increase reference | 0 | 1 |
| Reduce reference | 1 | 0 |
| Reduce reference | 1 | 1 |

A pulse of 24 V DC from terminal 12 is supplied to terminal 32 or 33 (logical "1") with a duration of between 20 msec. and 500 msec. will lead to a change of speed of 0.1 Hz. Logical "1" for more than 500 msec. will make the output frequency change at a rate determined by the ramps set in parameters 215 and 216.

The digital speed reference can be adjusted even if the unit has stopped (does not apply to motor coasting stop, quick-stop or DC-braking on terminal 27). The speed reference will be retained after an AC power outage if the speed reference was constant for at least 15 seconds. See parameter 014.

Choice of setup [2]:

If *multi-setup* has been selected in parameter 001, external switches can be used to select the active setup as shown in the table below. "1" represents 24 V from terminal 12.

| Setup | Terminal 33 | Terminal 32 |
|-------|-------------|-------------|
| 1 | 0 | 0 |
| 2 | 0 | 1 |
| 3 | 1 | 0 |
| 4 | 1 | 1 |

Four setups, extended [3]: This allows terminals 32 and 33 to be used to choose the desired parameter set or to change the speed of the drive as in speed up/down above. If freeze reference is not selected in parameter 400, 401 or 405, the terminals function as shown below. "1" represents 24 V from terminal 12.

| Setup | Terminal 32 | Terminal 33 |
|-------|-------------|-------------|
| 1 | 0 | 0 |
| 2 | 0 | 1 |
| 3 | 1 | 0 |
| 4 | 1 | 1 |

If, however, freeze reference is chosen in either parameter 400, 401 or 405, it will be possible to choose between two functions by means of terminal 16, 17 or 29. When no voltage is applied to terminal 16, 17 or 29, terminals function as shown below. "1" represents 24 V from terminal 12.

| Setup | Terminal 32 | Terminal 33 |
|-------|-------------|-------------|
| 1 | 0 | 0 |
| 2 | 0 | 1 |
| 3 | 1 | 0 |
| 4 | 1 | 1 |

When 24 V DC is applied to terminal 16, 17 or 29, the terminals function as shown below. "1" represents 24 V from terminal 12.

| | Terminal 33 | Terminal 32 |
|-------------------------------|-------------|-------------|
| Freeze reference (summarized) | 0 | 0 |
| Increase reference | 0 | 1 |
| Reduce reference | 1 | 0 |
| Reduce reference | 1 | 1 |

407 Terminal 42 Output (OUTPUT 42)

Value:

| | |
|------------------------------------------------------------------------|------|
| Control ready (CONTROL READY) | [0] |
| Unit ready (UNIT READY) | [1] |
| Ready - remote control (UNT RDY RCTL) | [2] |
| Enabled (ENABLED noWR) | [3] |
| Running (RUNNING) | [4] |
| Running, no warning (RUNNING noWR) | [5] |
| Running in range, no warning (RUNinRANGE) | [6] |
| Speed = reference, no warning (RUN@REF noWR) | [7] |
| Alarm (ALARM) | [8] |
| Alarm or warning (ALARM or WARN) | [9] |
| Current limit (CURRENT LIMIT) | [10] |
| Out of frequency range (OUT FREQ RGE) | [11] |
| Warning of low freq.(LO FREQ. WARN) | [12] |
| Warning of high freq.(HI FREQ. WARN) | [13] |
| Out of current range (OUT CURR RGE) | [14] |
| Warning of low current (LO CURR. WARN) | [15] |
| Warning of high current (HI CURR. WARN) | [16] |
| 0 to 100 Hz 0 to 20 mA(100 Hz 0 to 20 mA) | [17] |
| 0 to 100 Hz 4 to 20 mA(100 Hz 4 to 20 mA) | [18] |
| 0 to f_{MAX} 0 to 20 mA(Fmax 0 to 20 mA) | [19] |
| 0 to f_{MAX} 4 to 20 mA (Fmax 4 to 20 mA) | [20] |
| REF _{MIN} to REF _{MAX} 0 to 20 mA(REFmax 0 to 20 mA) | [21] |
| REF _{MIN} to REF _{MAX} 4 to 20 mA(REFmax 4 to 20 mA) | [22] |
| FB _{MIN} to FB _{MAX} 0 to 20 mA(FBmax 0 to 20 mA) | [23] |
| FB _{MIN} to FB _{MAX} 4 to 20 mA(FBmax 4 to 20 mA) | [24] |
| ★ 0 to I_{MAX} 0 to 20 mA(CURmax 0 to 20 mA) | [25] |
| ✓ 0 to I_{MAX} 4 to 20 mA(CURmax 4 to 20 mA) | [26] |
| 0 to I_{LIM} 0 to 20 mA(CURlim 0 to 20 mA) | [27] |
| 0 to I_{LIM} 4 to 20 mA(CURlim 4 to 20 mA) | [28] |
| 0 to kW_{MAX} 0 to 20 mA(PWRlim 0 to 20 mA) | [29] |
| 0 to kW_{MAX} 4 to 20 mA(PWRlim 4 to 20 mA) | [30] |

Function:

Terminals 42 and 45 can be programmed to give one of these output signals: 24 V DC, (max. 40 mA); 0 to 20 mA; or 4 to 20 mA.

The 24 V signal is used to report the status of a selected drive status. The 0 to 20 mA and 4 to 20 mA outputs are used for analog readouts.

Description of choice:

- [0] VLT is ready for use.
- [1] VLT is ready for use.
- [2] VLT is in the remote mode and is ready for use.
- [3] VLT is ready, there are no warnings.
- [4] VLT is running (output frequency is > 0.5 Hz or has a start signal).

- [5] VLT is running (output frequency is > 0.5 Hz or has a start signal), there are no warnings.
- [6] VLT is running within the programmed frequency and/or current range, there are no warnings.
- [7] VLT output frequency corresponds to the reference, there are no warnings.
- [8] There is an alarm.
- [9] There is a warning.
- [10] The current limit set in parameter 209 has been exceeded.
- [11] The motor is running out of the frequency range programmed in parameters 210 and 211.
- [12] The motor is running below the frequency programmed in parameter 210.
- [13] The motor is running above the frequency programmed in parameter 211.
- [14] The motor is running out of the current range programmed in parameters 212 and 213.
- [15] The motor current is below the current programmed in parameter 212.
- [16] The motor current is above the current programmed in parameter 213.
- [17- 18] The output signal represents the drive's speed, 20 mA represents an output frequency of 100 Hz. The minimum signal represents 0 Hz.
- [19-20] The output signal represents the drive's speed. 20 mA represents the frequency set in parameter 202. The minimum signal represents 0 Hz.
- [21-22] The output signal represents the total speed reference signal supplied to the drive from the three external inputs (set by parameters 401, 412, and 413) and the bus reference (set by parameter 516). 20 mA represents the maximum speed reference signal and the minimum signal represents the minimum speed reference signal. The drive does not have to be running to display this reference signal.
- [23-24] The output signal represents the feedback signal applied to terminal 17, 53 or 60, as setup by parameters 401, 412 or 413.
- [25-26] The output signal represents the output current from the drive. The maximum signal represents 110% of the drive's rated output current. The minimum signal represents no output current.
- [27-28] The output signal represents the output current from the drive. The maximum signal represents the current limit value, set in parameter 208.
- [29-30] The output signal represents the output power from the drive. The maximum signal represents the motor's rated power, which was entered in parameter 103.

★ = ROM default setting. ✓ = Normal Danfoss setup. Text in () = display text. Figures in [] are used when communicating with the bus.

408 Terminal 45 Output (OUTPUT 45)

| | | |
|----------------------------------------------|-----------------------------|------|
| Value: | | |
| Control ready (CONTROL READY) | | [0] |
| Unit ready (UNIT READY) | | [1] |
| Ready - remote control (UNT RDY RCTL) | | [2] |
| Enabled (ENABLED noWR) | | [3] |
| Running (RUNNING) | | [4] |
| Running, no warning (RUNNING noWR) | | [5] |
| Running in range, no warning (RUNinRANGE) | | [6] |
| Speed = reference, no warning (RUN@REF noWR) | | [7] |
| Alarm (ALARM) | | [8] |
| Alarm or warning (ALARM or WARN) | | [9] |
| Current limit (CURRENT LIMIT) | | [10] |
| Out of frequency range (OUT FREQ RGE) | | [11] |
| Warning of F low (LO FREQ. WARN) | | [12] |
| Warning of F high (HI FREQ. WARN) | | [13] |
| Out of current range (OUT CURR RGE) | | [14] |
| Warning of I low (LO CURR. WARN) | | [15] |
| Warning of I high (HI CURR. WARN) | | [16] |
| 0 to 100 Hz | 0 to 20 mA (100 Hz 0-20 mA) | [17] |
| 0 to 100 Hz | 4 to 20 mA(100 Hz 4-20 mA) | [18] |
| ★ 0 to f_{MAX} | 0 to 20 mA(Fmax 0-20 mA) | [19] |
| ✓ 0 to f_{MAX} | 4 to 20 mA (Fmax 4-20 mA) | [20] |
| REF_{MIN} to REF_{MAX} | 0 to 20 mA(REFmax 0-20 mA) | [21] |
| REF_{MIN} to REF_{MAX} | 4 to 20 mA(REFmax 4-20 mA) | [22] |
| FB_{MIN} to FB_{MAX} | 0 to 20 mA(FBmax 0-20 mA) | [23] |
| FB_{MIN} to FB_{MAX} | 4 to 20 mA(FBmax 4-20 mA) | [24] |
| 0 to I_{MAX} | 0 to 20 mA(CURmax 0-20 mA) | [25] |
| 0 to I_{MAX} | 4 to 20 mA(CURmax 4-20 mA) | [26] |
| 0 to I_{LIM} | 0 to 20 mA(CURlim 0-20 mA) | [27] |
| 0 to I_{LIM} | 4 to 20 mA(CURlim 4-20 mA) | [28] |
| 0 to kW_{MAX} | 0 to 20 mA(PWRlim 0-20 mA) | [29] |
| 0 to kW_{MAX} | 4 to 20 mA(PWRlim 4-20 mA) | [30] |

Function:

See function under parameter 407.

Description of choice:

See description of choice under parameter 407.

409 Terminal 01 Relay Output (RELAY 01)

| | | |
|----------------------------------------------------|--|------|
| Value: | | |
| Control ready (CONTROL READY) | | [0] |
| Unit ready (UNIT READY) | | [1] |
| Ready - remote control (UNT RDY RCTL) | | [2] |
| ✓ Enabled (ENABLED noWR) | | [3] |
| Running (RUNNING) | | [4] |
| Running, no warning (RUNNING noWR) | | [5] |
| Running in range, no warning (RUNinRANGE) | | [6] |
| Speed = reference, no warning (RUN@REF noWR) | | [7] |
| ★ Alarm (ALARM) | | [8] |
| Alarm or warning (ALARM or WARN) | | [9] |
| Current limit (CURRENT LIMIT) | | [10] |
| Out of frequency range (OUT FREQ RGE) | | [11] |
| Warning of F low (LO FREQ. WARN) | | [12] |
| Warning of F high (HI FREQ. WARN) | | [13] |
| Out of current range (OUT CURR RGE) | | [14] |
| Warning of I low (LO CURR. WARN) | | [15] |
| Warning of I high (HI CURR. WARN) | | [16] |
| Motor thermal overload (MOT.THERM.WARN) | | [17] |
| Ready and no motor thermal overload (READY+MOT.OK) | | [18] |
| Ready and remote control (RDY+MOT+REM) | | [19] |
| Ready and no over/undervoltage (RDY+DC V OK) | | [20] |
| Idle running current (NO LOAD CURR) | | [21] |

Function:

Relay output 01 and relay output 04 can be used for indicating status and warnings. The relay is activated when the conditions for the different data values are fulfilled. Activation/deactivation of relay 01 can be delayed by parameters 316 and 317. When relay 01 is active, its contacts connect terminal 01 to terminal 02. When it is not active, its contacts connect terminal 01 to terminal 03.

Description of choice:

- [0]-[16]: See explanations under parameter 407.
- [17] The electronic motor thermal overload indicates that the motor is overheated
- [18] VLT is ready and the electronic motor thermal protection indicates that there is no motor thermal overload.
- [19] VLT is ready and is in remote control mode (Auto).
- [20] VLT is ready and the DC bus voltage is OK.
- [21] The output current from the drive is below the idle running current set in parameter 232.

★ = ROM default setting. ✓ = Normal Danfoss setup. Text in () = display text. Figures in [] are used when communicating with the bus.

410 Terminal 04 Relay Output (RELAY 04)

Value:

- Control ready (CONTROL READY) [0]
- Unit ready (UNIT READY) [1]
- Ready - remote control (UNT RDY RCTL) [2]
- Enabled (ENABLED noWR) [3]
- ★ Running (RUNNING) [4]
- Running, no warning (RUNNING noWR) [5]
- Running in range, no warning (RUNinRANGE) [6]
- Speed = reference, no warning (RUN@REF noWR) [7]
- Alarm (ALARM) [8]
- Alarm or warning (ALARM or WARN) [9]
- Current limit (CURRENT LIMIT) [10]
- Out of frequency range (OUT FREQ RGE) [11]
- Warning of F low (LO FREQ. WARN) [12]
- Warning of F high (HI FREQ. WARN) [13]
- Out of current range (OUT CURR RGE) [14]
- Warning of I low (LO CURR. WARN) [15]
- Warning of I high (HI CURR. WARN) [16]
- Motor thermal overload (MOT.THERM.WARN) [17]
- Ready and no motor thermal overload (READY+MOT.OK) [18]
- Ready and remote control (RDY+MOT+REM) [19]
- Ready and no over-/undervoltage (RDY+DC V OK) [20]
- Idle running current (NO LOAD CURR) [21]

Function:

Relay outputs 01 and 04 can be used for indicating status and warnings.

The relay is activated when the conditions for the different data values are fulfilled. When relay 4 is activated, there is a connection between terminals 4 and 5.

Description of choice:

- [0]-[16] See explanations under parameter 407.
- [17]-[21] See explanations under parameter 409.

411 Analog Reference Type (ANALOG REFTYPE)

Value:

- ★ Linear between minimum and maximum (LINEAR) [0]
- Proportional with lower limit (PROP W/MIN.) [1]

Function:

It is possible to select different forms of how the output frequency is to depend on the analog reference signal.

Description of choice:

Used for deciding how the drive is to follow an analog reference signal, see graphs in next column.

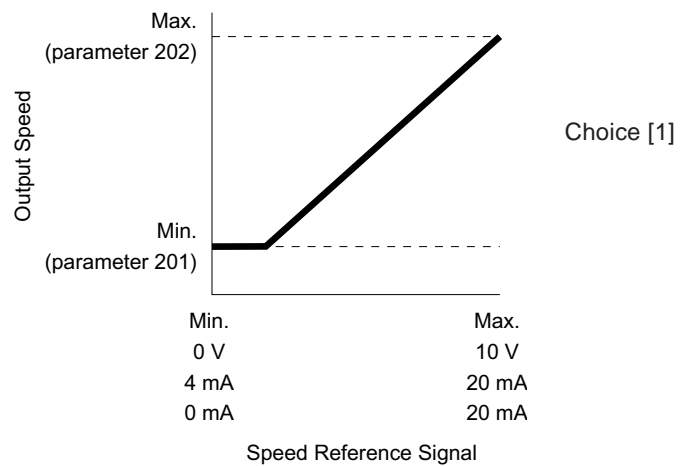
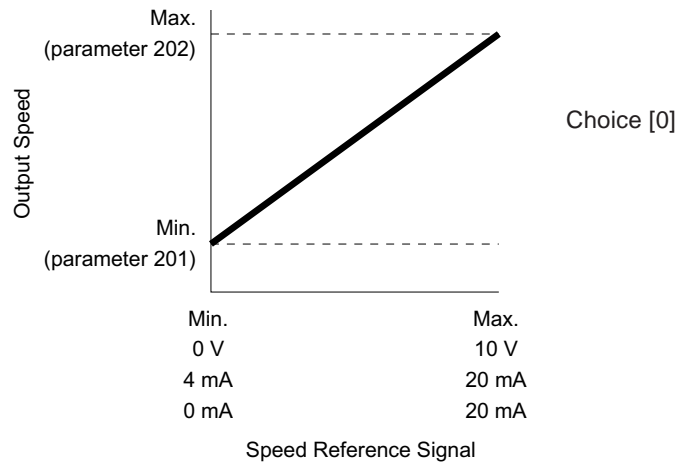

412 Terminal 53 Analog Input Voltage

(INPUT #53)

Value:

- ✓ No operation (NO OPERATION) [0]
- ★ 0 to 10 V (0 to 10 V DC) [1]
- 10 to 0 V (10 to 0 V DC) [2]
- 2 to 10 V (2 to 10 V DC) [3]
- 10 to 2 V (10 to 2 V DC) [4]
- 1 to 5 V (1 to 5 V DC) [5]
- 5 to 1 V (5 to 1 V DC) [6]

413 Terminal 60 Analog Input Current

(INPUT #60)

Value:

- No operation (NO OPERATION) [0]
- ★ 0 to 20 mA (0 to 20 mA) [1]
- ✓ 4 to 20 mA (4 to 20 mA) [2]
- 20 to 0 mA (20 to 0 mA) [3]
- 20 to 4 mA (20 to 4 mA) [4]

Function (parameters 412 and 413):

Choose the desired analog input references.

Description of choice (parameters 412 and 413):

Enter the type of analog input signals to inputs 53 and 60. Choose voltage or current, and whether the signals are to be normal or inverted. If two inputs are used for reference signals, the total reference signal is the sum of those two signals. If a PID controller is used without latched input being used (terminal 17 parameter 401), one of the inputs must be used for the feedback signal. If current control is used as selected in parameter 102, one of these inputs must be for setting the current limit.



NOTE:

If terminal 53 and/or terminal 60 is not used, NO OPERATION [0] must be chosen in parameters 412 or 413 to avoid a reference fault.



NOTE:

If a 4 to 20 mA, 20 to 4 mA, 2 to 10 V, 10 to 2 V, 1 to 5 V, or 5 to 1 V reference signal is chosen and no reference signal is connected, the drive will display a reference fault. These are also chosen in Quick Set Up Menu steps 4 and 5.

414 Time Out Interval (TIME OUT)

Value:

- 0 to 99 seconds ★100 = OFF
- ✓ 005 sec

415 Time Out Interval Function (TIME OUT A)

Value:

- ★ Freeze (FREEZE) [0]
- Stop (STOP) [1]
- Jogging (JOG) [2]
- Max. speed (MAX) [3]

Function: (parameters 414 and 415):

If one of the “live zero” signals, such a 4 to 20 mA, has been selected and the actual signal is less than 50% of this minimum value, REF FAULT will be displayed immediately. The desired operating mode selected in parameter 415 will be followed after the programmed time delay set in parameter 414 has expired.

Description of choice: (parameters 414 and 415):

The desired operating mode is selected in parameter 415. *Freeze [0]* makes the drive go to the speed which is associated with the minimum speed reference signal. *Stop [1]* stops the drive by setting its output frequency to 0 Hz. *Jog [2]* sets the drive to the speed set in parameter 203. *Max [3]* sets the drive to its maximum frequency.

This function is not active during “Local/Hand” operation or when closed loop control has been selected in parameter 101.

420 Reference Type to H-O-A (EXT.HOA RE)

Value:

- ★ Voltage #53 [0]
- Current #60 [1]
- Speed up/down (SPEED UP/DOWN) [2]

Function:

When external H-O-A is selected in parameter 003, a reference for manual operation (Hand) must be selected. This reference cannot be the same one that is used for remote control (Auto).

Description of choice:

If *Voltage #53 [0]* is selected, an analog voltage reference at terminal #53 is used, which is programmed in parameter 412.

If *Current #60 [1]* is selected, an analog current reference at terminal #60 is used, which is programmed in parameter 413.

If *Speed Up/Down [2]* is selected, digital speed up/down (floating point control) is used, which is programmed in parameter 406.

★ = ROM default setting. ✓ = Normal Danfoss setup. Text in () = display text. Figures in [] are used when communicating with the bus.

Group 5 -- Serial Data Interface

The RS 485 serial bus (terminals 68 and 69) allows the reading and setting of the drive's parameters, as well as transmitting reference and control commands to it.

The serial bus can be used by up to 31 drives per master without using a repeater. If 3 repeaters are used, up to 99 drives can be connected to one master.

Danfoss can provide a serial communication program "VLS Dialog", which allows an IBM compatible personal computer (PC) to communicate with VLT drives over an RS 485 serial interface. This program allows controlling the drive(s) remotely through the computer without the need for any additional programming. Contact Danfoss literature department for information.

It is important to connect and terminate the serial bus with the correct impedance to avoid any reflections which may disturb the data transmission in the cable. Set the switches 03.1 and 03.2 in the "on" position in the last drive connected to the serial bus.

The following information provides detailed specifications of the serial communications format for those who wish to customize their own serial communications software. Communication takes place by means of a special protocol.

The data format consists of 10 bits; one start bit (logical 0), eight data bits and one stop bit (logical 1). There is no parity check. Set the speed of transmission in parameter 501 and the address of each unit in parameter 500.

Message (telegram) format (protocol)

The communication protocol consists of 22 ASCII characters. These characters make it possible to operate, set and read parameters and to receive status feedback from the drive.

Communication takes place as follows:

The master sends a message to the drive. Then the master awaits a reply from the drive before sending a new message. The reply to the master is a copy of the message sent by the master, now containing any updated data values and the status of the drive.

Data format

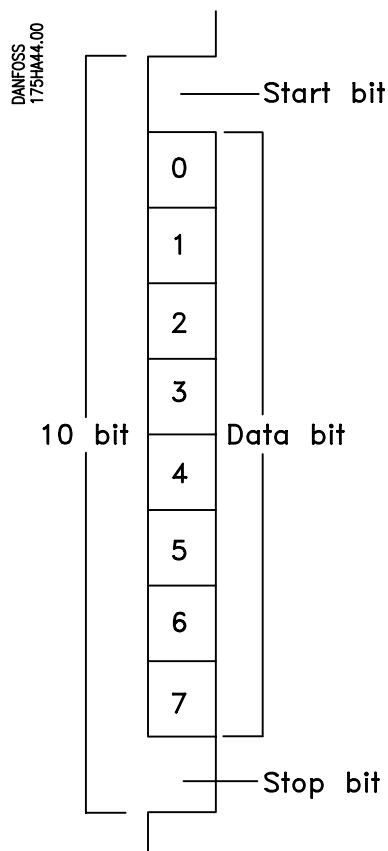

Telegram format

| Function | byte # | ASCII |
|---------------------|--------|-------|
| Start byte | 1 | < |
| Address | 2 | |
| | 3 | |
| Control char. | 4 | |
| Control/status word | 5 | |
| | 6 | |
| | 7 | |
| | 8 | |
| Parameter # | 9 | |
| | 10 | |
| | 11 | |
| | 12 | |
| Sign | 13 | |
| Data | 14 | |
| | 15 | |
| | 16 | |
| | 17 | |
| | 18 | |
| | 19 | |
| Comma | 19 | |
| Check sum | 20 | |
| | 21 | |
| Stop byte | 22 | > |

DANFOSS 175HA043.11

Byte 1:

Start byte, which in this case must be the character "<" (ASCII: 60).

Byte 2 and 3:

The two-digit address of the frequency converter. This address is also programmed in parameter 500. Sending to address 00 means transmission to all units connected to the bus. None of the units will reply, but they will carry out the command.

Byte 4:

Control parameter telling the drive what to do with the following data values.

U (update)

Means that the data value, bytes 13 through 19, must be read into the drive parameter specified by bytes 9 through 12.

R (read)

Means that the master wishes to read the data value of the parameter in bytes 9 through 12.

C (control)

Means that the frequency converter reads only the four command bytes, 5 through 8, and returns with status. Parameter number and data value are ignored.

I (read index)

Means that the frequency converter reads the index and parameter and returns with status. The parameter is stated in bytes 9 through 12 and index is stated in bytes 13 through 18.

Parameters with indices are read-only parameters. Action will be taken on the control word. Two-dimensional indices (x,y) (parameters 601 and 602) are separated by a comma, see byte 19.

Example:

| | | |
|--------------------|---|--------|
| Index | = | x, y |
| Data value | = | 013.05 |
| | | ↓ |
| Byte 14 through 18 | = | 01305 |
| Byte 19 | = | 2 |

Byte 5 through 8:

Control and status words, used to send commands to the frequency converter and to send status from the frequency converter to the master.

Byte 9 through 12:

The parameter number is inserted in these bytes.

Byte 13:

Used for the sign before data value in bytes 14 through 18. All characters other than "-" are taken as "+".

Byte 14 through 18:

Here is placed the data value of the parameter stated in bytes 9 through 12. The value must be a whole number. If a decimal point is needed, it is stated in byte 19.



NOTE:

Some data values have brackets with a number, for example "[0]". Use this number instead of the "Text" data value.

Byte 19:

The position of the decimal point in the data value stated in bytes 14-18. The number states the number of characters after the decimal point. Consequently, byte 19 can be 0, 1, 2, 3, 4 or 5. For example, the number 23.75 is stated:

| | | | | | | | | |
|--------------------|---|----|----|----|----|----|----|----|
| Byte no. | | 13 | 14 | 15 | 16 | 17 | 18 | 19 |
| in ASCII character | + | 2 | 3 | 7 | 5 | 0 | 3 | |

If byte 19 = 9, this indicates an unknown parameter.

Byte 20 and 21:

Used for check sum control from bytes 2 up to and including 19. The decimal values of the ASCII characters are added and reduced to the two low characters, for example: $\Sigma 235 - \text{reduced} = 35$. If there is to be no control, the function can be cancelled by means of the "?" character (ASCII: 63) in the two bytes.

Byte 22:

Stop byte, stating the end of the telegram. The character ">" is used (ASCII: 62).

Control Word, bytes 5 through 8 in the message. The control word is used to send control commands from the controller to the drive. According to the data format, 1 byte consists of 8 databits, but in the control word only the 4 least significant bits of each byte are used, which means that ASCII characters from A to O can be used. The table below gives the meaning of the individual bits in the control word.

| ASCII | | CONTROL WORD | | | | | | | | | | | | | | | |
|-------|----------------------------------------------------------------------------------------|----------------------------|----------------------------|--------------------------------------|--------------------------------------|-----------------------|-----------------------|-------------|--------------------------------------|-----------------------|---------------------------------|---------------------------------|------------------------------------------------|-----------------------|-------------|-------------|-------------|
| | | Byte 8 | | | | Byte 7 | | | | Byte 6 | | | | Byte 5 | | | |
| | | N O | C H O I C E | C H O I C E | N O | N O | D A T A | J O G | J O G | N O | R A M P | H O L D | Q U I C K - S T O P | C O A S T | O F F | O F F | O F F |
| 0 | F U N C T I O N / R E V E R S I N G | O F | O F | F U N C T I O N | F U N C T I O N | N O T | O F F | O F F | F U N C T I O N | S T O P | / | R A M P | / | / | / | / | |
| 1 | S E T - U P | S E T - U P | S E T - U P | / | / | V A L I D | / | / | / | S T A R T | E N A B L E D | E N A B L E D | 3 | 2 | 1 | | |
| | | 2 | 1 | C A T C H - U P | S L O W D O W N | / | V A L I D | O N | O N | R E S E T | | | | | | | |
| | | 15 | 14 | 13 | 12 | 11 | 10 | 09 | 08 | 07 | 06 | 05 | 04 | 03 | 02 | 01 | 00 |
| @ | | 0 | 0 | 0 | 0 | 0 | 0 | 0 | 0 | 0 | 0 | 0 | 0 | 0 | 0 | 0 | 0 |
| A | | 0 | 0 | 0 | 1 | 0 | 0 | 0 | 1 | 0 | 0 | 0 | 1 | 0 | 0 | 0 | 1 |
| B | | 0 | 0 | 1 | 0 | 0 | 0 | 1 | 0 | 0 | 0 | 1 | 0 | 0 | 0 | 1 | 0 |
| C | | 0 | 0 | 1 | 1 | 0 | 0 | 1 | 1 | 0 | 0 | 1 | 1 | 0 | 0 | 1 | 1 |
| D | | 0 | 1 | 0 | 0 | 0 | 1 | 0 | 0 | 0 | 1 | 0 | 0 | 0 | 1 | 0 | 0 |
| E | | 0 | 1 | 0 | 1 | 0 | 1 | 0 | 1 | 0 | 1 | 0 | 1 | 0 | 1 | 0 | 1 |
| F | | 0 | 1 | 1 | 0 | 0 | 1 | 1 | 0 | 0 | 1 | 1 | 0 | 0 | 1 | 1 | 0 |
| G | | 0 | 1 | 1 | 1 | 0 | 1 | 1 | 1 | 0 | 1 | 1 | 1 | 0 | 1 | 1 | 1 |
| H | | 1 | 0 | 0 | 0 | 1 | 0 | 0 | 0 | 1 | 0 | 0 | 0 | 1 | 0 | 0 | 0 |
| I | | 1 | 0 | 0 | 1 | 1 | 0 | 0 | 1 | 1 | 0 | 0 | 1 | 1 | 0 | 0 | 1 |
| J | | 1 | 0 | 1 | 0 | 1 | 0 | 1 | 0 | 1 | 0 | 1 | 0 | 1 | 0 | 1 | 0 |
| K | | 1 | 0 | 1 | 1 | 1 | 0 | 1 | 1 | 1 | 0 | 1 | 1 | 1 | 0 | 1 | 1 |
| L | | 1 | 1 | 0 | 0 | 1 | 1 | 0 | 0 | 1 | 1 | 0 | 0 | 1 | 1 | 0 | 0 |
| M | | 1 | 1 | 0 | 1 | 1 | 1 | 0 | 1 | 1 | 1 | 0 | 1 | 1 | 1 | 0 | 1 |
| N | | 1 | 1 | 1 | 0 | 1 | 1 | 1 | 0 | 1 | 1 | 1 | 0 | 1 | 1 | 1 | 0 |
| O | | 1 | 1 | 1 | 1 | 1 | 1 | 1 | 1 | 1 | 1 | 1 | 1 | 1 | 1 | 1 | 1 |
| P | | 1 | 1 | 1 | 1 | 1 | 1 | 1 | 1 | 1 | 1 | 1 | 1 | 1 | 1 | 1 | 1 |

X = Indifferent; if P is used in a group of 4 bits, the current status is maintained. Only the groups with characters ≠ P are activated. Bit 10 = 0 means that there is no change from the current status.

Bit 00, OFF1/ON1:

Ordinary ramp stop using the ramp time in parameter 216. Bit 00 = "0" causes a stop; bit 00 = "1" means that the drive is able to start if the other conditions for doing so have been fulfilled.

Bit 01, OFF2/ON2:

Coast stop. Bit 01 = "0" causes a coast stop; bit 01 = "1" means that the frequency converter is able to start if the other conditions for doing so have been fulfilled.

Bit 02, OFF3/ON3:

Quick-stop using the ramp time in parameter 218. Bit 02 = "0" causes a quick-stop; bit 02 = "1" means that the drive is able to start if the other conditions for doing so have been fulfilled.

Bit 03, COAST/ENABLED:

Coast stop. Bit 03 = "0" causes a stop; bit 03 = "1" drive is able to start if the other conditions for doing so have been fulfilled. Note: In parameter 503 a choice is made as to how bit 03 is to be combined with the corresponding function on the digital inputs.

Bit 04, QUICK-STOP/RAMP:

Quick-stop using the ramp time in parameter 218. Bit 04 = "0" causes a quick-stop; bit 04 = "1" means that the drive is able to start if the other conditions for doing so have been fulfilled.

The function of bit 04 can be redefined to DC braking in parameter 514; otherwise the function is as described. Note: In parameter 504 and 505 a choice is made as to how bit 04 is combined with the corresponding function on the digital inputs.

Bit 05, HOLD/RAMP ENABLED:

Ordinary ramp stop using the ramp time in parameter 216. Bit 05 = "0" leads to a stop; bit 05 = "1" means that the drive is able to start if the other conditions for doing so have been fulfilled.

Bit 06, RAMP STOP/START:

Ordinary ramp stop using the ramp time in parameter 216. Bit 06 = "0" causes a stop; bit 06 = "1" means that the drive is able to start if the other conditions for doing so have been fulfilled. Note: In parameter 506 a choice is made as to how bit 06 is combined with the corresponding function on the digital inputs.

Bit 07, NO FUNCTION/RESET:

Reset of trip. Bit 07 = "0" causes no reset; bit 07 = "1" means that a trip is reset. Note: In parameter 508 a choice is made as to how bit 07 is combined with the corresponding function on the digital inputs.

Bit 08, JOG 1 OFF/ON:

Activation of the pre-programmed speed in parameter 511 (Bus JOG 1). JOG 1 is only possible when bit 04 = "0" and bit 00-03 = "1".

Bit 09, JOG 2 OFF/ON:

Activation of the pre-programmed speed in parameter 512 (Bus JOG 2). JOG 2 is only possible when bit 04 = "0" and bit 00-03 = "1". If both JOG 1 and JOG 2 are activated (bits 08 and 09 = "1"), JOG 1 has the higher priority, i.e. the speed programmed in parameter 511 is used.

Bit 10, DATA NOT VALID/VALID:

Used for telling the drive whether the control word is to be used or ignored. Bit 10 = "0" means that the control word is ignored. Bit 10 = "1" means that the control word is used. This function is relevant because the control word is always contained in the message, no matter what type of message is being used (see byte 4), i.e. it is possible to disregard the control word if it is not to be used in connection with updating or reading of parameters.

Bit 11, NO FUNCTION/SLOW DOWN:

Used for reducing the speed reference by the value of parameter 513.

Bit 11 = "0" means that the reference is not changed.

Bit 11 = "1" means that the reference is reduced. The function of bits 11 and 12 can be redefined to be the choice of digital reference in parameter 515, in accordance with the following table:

| Digital reference/ parameter | Bit 14 | Bit 13 |
|---------------------------------|--------|--------|
| 1/205 | 0 | 0 |
| 2/206 | 0 | 1 |
| 3/207 | 1 | 0 |
| 4/208 | 1 | 1 |



NOTE:

In parameter 510 a choice is made of how bit 1/12 is combined with the corresponding function on the digital inputs.

Bit 12, NO FUNCTION/CATCH-UP:

Used to increase the speed reference by the value of parameter 513. Bit 12 = "0" means that the reference is not changed; bit 12 = "1" means that the reference is increased. If both slow-down and catch-up are activated (bits 11 and 12 = "1"), slow-down has the higher priority, i.e. that the speed reference is reduced. The function of bits 11 and 12 can be redefined to become the choice of digital reference; see the description of bit 11 in the above.

Bit 13/14, CHOICE OF SETUP:

Bits 13 and 14 are used for choosing between the four menu setups, in accordance with the following table:

| Setup | Bit 14 | Bit 13 |
|-------|--------|--------|
| 1 | 0 | 0 |
| 2 | 0 | 1 |
| 3 | 1 | 0 |
| 4 | 1 | 1 |

This function is only enabled if *Multi setups* have been selected in parameter 001.



NOTE:

In parameter 509 a choice is made of how bit 13/14 is combined with the corresponding function on the digital inputs.

Bit 15, NO FUNCTION/REVERSING:
 Reversing of the direction of rotation of the motor. Bit 15 = "0" leads to no reversing; bit 15 = "1" leads to reversing.
 Please note that the original setting for reversing in parameter 507 is *digital*; bit 15 only leads to reversing if *bus*,

logical or or logical and has been selected (*logical and* only in connection with terminal 19).

Example:

The following control word can be used if the drive is to be given a start command:

| | | | | | | | | | | | | | | | | |
|-------|----|----|----|----|----|----|----|----|----|----|----|----|----|----|----|----|
| Bit | 15 | 14 | 13 | 12 | 11 | 10 | 09 | 08 | 07 | 06 | 05 | 04 | 03 | 02 | 01 | 00 |
| 0/1 | 0 | 0 | 0 | 0 | 0 | 1 | 0 | 0 | 0 | 1 | 1 | 1 | 1 | 1 | 1 | 1 |
| ASCII | @ | | | | D | | | | G | | | | O | | | |

Status Word, bytes 5 through 8 in the message:

The status word is used to inform the controller about the status of the drive.

The status word has been placed in bytes 5 through 8 in the response message from the drive to the controller. The below table gives the meaning of the individual bits of the status word:

| ASCII | | Status word | | | | | | | | | | | | | | | |
|-------|---|----------------------------|---------------------------------|---------------------------------|-----------------------|------------------|------------------|-----------------------|-----------------------|-------------------|-----------------------|--------|--------|---------|-----------------------|-------------|--------------------------------------|
| | | Byte 8 | | | | Byte 7 | | | | Byte 6 | | | | Byte 5 | | | |
| | | T I M E R S | C U R R E N T | V O L T A G E | V L T O K | D O E S | O U T | L O C A L | S P E E D | N O | S T A R T | O N | O N | N O | C O A S T | V L T | C O N T R O L S |
| 0 | 1 | OK | OK | OK | OK | NOT RUN | OPERATING | ≠ REF | WARNINGS | ENABLED | OFF | OFF | FAULT | ENABLED | NOT READY | NOT READY | |
| 1 | 0 | OVERSHOOT | OVERSHOOT | OVERSHOOT | STALLS | RUNS | RANGE/FREQ LIMIT | = REF | WARNINGS | START NOT ENABLED | 3 | 2 | TRIP | ENABLED | READY | READY | |
| | | 15 | 14 | 13 | 12 | 11 | 10 | 09 | 08 | 07 | 06 | 05 | 04 | 03 | 02 | 01 | 00 |
| @ | | 0 | 0 | 0 | 0 | 0 | 0 | 0 | 0 | 0 | 0 | 0 | 0 | 0 | 0 | 0 | 0 |
| A | | 0 | 0 | 0 | 1 | 0 | 0 | 0 | 1 | 0 | 0 | 0 | 1 | 0 | 0 | 0 | 1 |
| B | | 0 | 0 | 1 | 0 | 0 | 0 | 1 | 0 | 0 | 0 | 1 | 0 | 0 | 0 | 1 | 0 |
| C | | 0 | 0 | 1 | 1 | 0 | 0 | 1 | 1 | 0 | 0 | 1 | 1 | 0 | 0 | 1 | 1 |
| D | | 0 | 1 | 0 | 0 | 0 | 1 | 0 | 0 | 1 | 0 | 0 | 0 | 0 | 1 | 0 | 0 |
| E | | 0 | 1 | 0 | 1 | 0 | 1 | 0 | 1 | 0 | 1 | 0 | 1 | 0 | 1 | 0 | 1 |
| F | | 0 | 1 | 1 | 0 | 0 | 1 | 1 | 0 | 0 | 1 | 1 | 0 | 0 | 1 | 1 | 0 |
| G | | 0 | 1 | 1 | 1 | 1 | 0 | 1 | 1 | 0 | 1 | 1 | 1 | 0 | 1 | 1 | 1 |
| H | | 1 | 0 | 0 | 0 | 1 | 0 | 0 | 0 | 1 | 0 | 0 | 0 | 1 | 0 | 0 | 0 |
| I | | 1 | 0 | 0 | 1 | 1 | 0 | 0 | 1 | 1 | 0 | 0 | 1 | 1 | 0 | 0 | 1 |
| J | | 1 | 0 | 1 | 0 | 1 | 0 | 1 | 0 | 1 | 0 | 1 | 0 | 1 | 0 | 1 | 0 |
| K | | 1 | 0 | 1 | 1 | 1 | 0 | 1 | 1 | 1 | 0 | 1 | 1 | 1 | 0 | 1 | 1 |
| L | | 1 | 1 | 0 | 0 | 1 | 1 | 0 | 0 | 1 | 1 | 0 | 0 | 1 | 1 | 0 | 0 |
| M | | 1 | 1 | 0 | 1 | 1 | 1 | 0 | 1 | 1 | 1 | 0 | 1 | 1 | 1 | 0 | 1 |
| N | | 1 | 1 | 1 | 0 | 1 | 1 | 1 | 0 | 1 | 1 | 1 | 0 | 1 | 1 | 1 | 0 |
| O | | 1 | 1 | 1 | 1 | 1 | 1 | 1 | 1 | 1 | 1 | 1 | 1 | 1 | 1 | 1 | 1 |

Bit 00, CONTROLS NOT READY / READY:

Bit 00 = "0" means that bit 00, 01 or 02 of the control word is "0" (OFF1, OFF2 or OFF3), or that the drive has tripped. Bit 00 = "1" means that the drive is ready to run when it receives the necessary start signals.

Bit 01, DRIVE NOT READY / READY:

Same meaning as bit 00.

Bit 02, COAST/ENABLED:

Bit 02 = "0" means that bit 00, 02 or 03 of the control word is "0" (OFF1, OFF2, OFF3 or Coasting), or that drive has tripped. Bit 02 = "1" means that bits 00, 01, 02 and 03 of the control word is "1", and that the drive has not tripped.

Bit 03, NO FAULT/TRIP:

Bit 03 = "0" means that the drive is not in a state of fault; bit 03 = "1" means that the drive has tripped and that it requires a reset signal before being able to run.

Bit 04, ON2/OFF2:

Bit 04 = "0" means that bit 01 of the control word = "1".
Bit 04 = "1" means that bit 01 of the control word = "0".

Bit 05, ON3/OFF3:

Bit 05 = "0" means that bit 02 of the control word = "1".
Bit 05 = "1" means that bit 02 of the control word = "0".

Bit 06, START ENABLED/NOT ENABLED:

Bit 06 is always "0" if "Start not Enabled" [11] has not been selected in parameter 309. If "Start not Enabled" [11] has been selected in parameter 309, bit 06 will be "1" after reset of a trip, after activation of OFF2 or OFF3 and after connection to AC line voltage. "Start not Enabled" is reset, setting bit 00 of the control word at "0" and bits 01, 02 and 10 at "1".

Bit 07, NO WARNING/WARNING:

Bit 07 = "0" means that there is no unusual situation; bit 07 = "1" means that an unusual situation has arisen for the drive. All warnings will make bit 07 go to "1".

Bit 08, SPEED REF/SPEED = REF.:

Bit 08 = "0" means that the current speed of the motor is different from the speed reference. This could be the case, for example, while the speed is being ramped up/down at start/stop. Bit 08 = "1" means that the current speed of the motor is equal to the preset speed reference.

Bit 09, LOCAL CONTROL/BUS CONTROL:

Bit 09 = "0" means that the drive has stopped by means of the stop key on the operating panel, or that "local" or "local with external coasting stop" has been selected in parameter 003. Bit 09 = "1" means that it is possible to control the frequency converter via the serial port.

Bit 10, OUT OF RANGE/FREQUENCY OK:

Bit 10 = "0" means that the output frequency is outside the limited set in parameter 210 (Warning: Low frequency) and parameter 211 (Warning: High frequency). Bit 10 = "1" means that the output frequency lies within the mentioned limits.

Bit 11, DOES NOT RUN/RUNS:

Bit 11 = "0" means that the drive does not run. Bit 11 = "1" means that the drive has received a start signal, or that the output frequency is higher than 0.5 Hz.

Bit 12, VLT OK/STALLS, AUTOSTART:

Bit 12 = "0" means that there is no temporary overloading of the inverter; bit 12 = "1" means that the inverter has stopped because of an overload, but that the drive has not tripped. The unit will continue to work when the overload has disappeared.

Bit 13, OK/OVER- OR UNDERVOLTAGE:

Bit 13 = "0" means that the drive's voltage limits have not been exceeded. Bit 13 = "1" means that the DC bus voltage is too low or too high.

Bit 14, CURRENT OK/OVERSHOOT:

Bit 14 = "0" means that the motor current is smaller than the current limit selected in parameter 209. Bit 14 = "1" means that the current limit of parameter 209 has been exceeded.

Bit 15, TIMERS OK/OVERSHOOT:

Bit 15 = "0" means that the timers for thermal motor protection and thermal drive protection have not exceeded 100%.
 Bit 15 = "1" means that one of the timers has exceeded 100%.

Example:

The status word below says that the motor is running on the desired speed reference, but outside the defined frequency area. Consequently, bit 10 = "0" (out of frequency range) and bit 07 = "1" (warning). Voltage, current and timers are OK.

| | | | | | | | | | | | | | | | | |
|-------|----|----|----|----|----|----|----|----|----|----|----|----|----|----|----|----|
| Bit | 15 | 14 | 13 | 12 | 11 | 10 | 09 | 08 | 07 | 06 | 05 | 04 | 03 | 02 | 01 | 00 |
| 0/1 | 0 | 0 | 0 | 0 | 1 | 0 | 1 | 1 | 1 | 0 | 0 | 0 | 0 | 1 | 1 | 1 |
| ASCII | @ | | | K | | | | H | | | G | | | | | |

Message Example:

A drive, with address 1, is to be given a start signal and a speed reference that corresponds to 40 Hz.

A start signal is given by means of the control word and the speed reference is given to parameter 516, bus reference, 80% corresponding to 40 Hz, since the maximum frequency is 50 Hz. This results in the following message:

Message from the master (PC or PLC) to the frequency converter

| Function | Byte Number | ASCII Character | Decimal Value |
|--------------------|-------------|-----------------|---------------|
| Start-byte | 1 | < | 60 |
| Address | 2 | 0 | 48 |
| | 3 | 1 | 49 |
| Control character | 4 | U | 85 |
| Control/statusword | 5 | O | 79 |
| | 6 | G | 71 |
| | 7 | D | 68 |
| | 8 | @ | 64 |
| Parameter no. | 9 | 0 | 48 |
| | 10 | 5 | 53 |
| | 11 | 1 | 49 |
| | 12 | 6 | 54 |
| Sign | 13 | + | 43 |
| Datavalue | 14 | 0 | 48 |
| | 15 | 0 | 48 |
| | 16 | 0 | 48 |
| | 17 | 8 | 56 |
| | 18 | 0 | 48 |
| Decimal point | 19 | 0 | 48 |
| Check-sum | 20 | 0 | 48 |
| | 21 | 7 | 55 |
| Stop-byte | 22 | > | 62 |

Check-sum: bytes 2-19 = 1007, reduced to 07.

Response Message from the Drive to the Controller:

| Function | Byte no. | ASCII-character | Decimal value |
|--------------------|----------|-----------------|---------------|
| Start-byte | 1 | < | 60 |
| Address | 2 | 0 | 48 |
| | 3 | 1 | 49 |
| Control character | 4 | U | 85 |
| Control/statusword | 5 | G | 71 |
| | 6 | H | 72 |
| | 7 | K | 75 |
| | 8 | @ | 64 |
| Parameter no. | 9 | 0 | 48 |
| | 10 | 5 | 53 |
| | 11 | 1 | 49 |
| | 12 | 6 | 54 |
| Sign | 13 | + | 43 |
| Datavalue | 14 | 0 | 48 |
| | 15 | 0 | 48 |
| | 16 | 0 | 48 |
| | 17 | 8 | 56 |
| | 18 | 0 | 48 |
| Decimal point | 19 | 0 | 48 |
| Check-sum | 20 | 0 | 48 |
| | 21 | 7 | 55 |
| Stop-byte | 22 | > | 62 |

Check-sum: bytes 2 through 19 = 1007, reduced to 07.

Fault Messages for Read/Write Parameters:

Byte 19 in the response message from the drive takes the value 9 if it is not possible to carry out the selected write or read command. At the same time, a cause code is given in bytes 17 and 18. The following cause codes exist:

Code Cause

- 00 The parameter number does not exist
- 01 There is no read/write access to the selected parameter
- 02 A nonexisting index no. has been selected
- 03 Index reading is used for a parameter that has no indices
- 04 The parameter is write-protected (read only). This may be because the factory set-up has been selected
- 05 The parameter cannot be changed while the motor is running
- 06 The data value lies outside the parameter range
- 07 Illegal command value (Byte 19)
- 08 The data value read is > 99999
- 99 Other fault

Switch 04:

- 04 closed: Terminal 61 is connected to chassis ground.
- 04 open: Terminal 61 is connected to chassis ground via an RC link.

When switch 04 is closed, there is no voltage isolation between the signal lines (terminals 68 and 69) and the ground. This may lead to noise problems if a controller which is not isolated from earth ground is used. In this case, the RS 485 connection should be made as follows: Switch 04 must be open, the shield of the signal cable must be connected to the cable clamp below the control card, but not to terminal 61. The shield should be left on the wire and should extend as close to the terminal strip as possible. The shield should be insulated, to avoid contact with other circuitry.

★ = ROM default setting. ✓ = Normal Danfoss setup. Text in () = display text. Figures in [] are used when communicating with the bus.

Serial Communication Parameters

500 Address (ADDRESS)

Value:

01 to 99 ★ 01

Function:

Specifies the address of each VLT drive. If the master (PLC or PC) gives the address 00, communication is sent to all linked VLT drives at the same time. In that case the unit does not send back a response to the master. If the number of units exceeds 31, a repeater must be used. Parameter 500 must be set locally at each unit. It cannot be selected via the serial bus.

501 Bits/Sec. Baud Rate (BAUD RATE)

Value:

300, 600, 1200, 2400, 4800, 9600 ★9600

Function:

This parameter sets the speed at which data are transmitted.

This value is defined as the number of bits transmitted per second. The transmission speed of the VLT drive must be set to match the PC or PLC transmission speed. Parameter 501 must be set locally at each unit. It cannot be selected via the serial bus. The data transmission time itself, which is determined by the set baud rate, is only part of the total communication time. The total time for sending to the VLT drive and receiving a response is between 320 msec. and 480 msec.

502 Data Readout (DATA READO)

Value:

| | |
|----------------------------------------|-------------------|
| ★ 0 | Reference |
| (REFERENCE %) | ----% |
| 1 Frequency (FREQUENCY Hz) | ----Hz |
| 2 Display/Feedback (FEEDBACK UNIT) | ----“unit” |
| 3 Current (CURRENT A) | ----A |
| 4 Torque (TORQUE %) | ----% |
| 5 Power (POWER kW) | ----kW |
| 6 Power (POWER HP) | ----HP |
| 7 Energy (ENERGY kWh) | ----kWh |
| 8 Motor voltage (OUTPUT VOLT.V) | ----V |
| 9 DC voltage (DC BUS V) | ----V |
| 10 Motor thermal load (ETR (MOT) %) | ----% |
| 11 Thermal inverter load (ETR (VLT) %) | ----% |
| 12 Digital input (DIG INP. CODE) | binary code |
| 13 Analog input 1 (ANALOG IN 53) | in terminal 53 |
| 14 Analog input 2 (ANALOG IN 60) | in terminal 60 |
| 15 Warning parameter (WARNING CODE) | binary code |
| 16 Control word (CONTROL WORD) | |
| 17 Status word (STATUS WORD) | |
| 18 Alarm parameter (ALARM CODE) | binary code |

Function:

This parameter is a read-only parameter. It is used for reading out display texts, status messages, warnings and alarms via the serial bus.

The data values for parameter 502 cannot be read out on the display. The individual data values are read using index reading, by setting byte 4 of the control word to “1”. The index number of the data value to be read is given in bytes 14 through 19.

502 Data Read-Out (DATA READOUT) continued

Description of choice:

Index 0 to 11:

These are the twelve display values which are also available in the Extended Display. Only the value of the display is sent via the serial interface, not the unit.

Index "0". REFERENCE %, represents only external speed reference signals: analog inputs on terminals 53 and 60, the pulse from input on terminal 17, and the serial bus reference. It does not include the jog speed set by parameter 203 or the digital references set by parameters 205 through 208.

Index 12:

A decimal value, which is to be converted to an 8-bit binary code. This represents the status of the binary inputs.

Example:

| | | | | | | | | |
|----------|----|----|----|----|----|----|----|----|
| Decimal | 16 | | | | | | | |
| Binary | 0 | 0 | 0 | 1 | 0 | 0 | 0 | 0 |
| Terminal | 33 | 32 | 29 | 27 | 19 | 18 | 17 | 16 |

Index 13 and 14:

A decimal value between 0 and 1023, where 0 corresponds to 0% and 1023 corresponds to 100% of the selected input signal, for example 0 to 10 V DC.

Index 15:

A decimal value which is to be converted to a 16-bit binary number. Each bit represents a warning in accordance with the table below. When a warning is present, the corresponding bit has the value "1".

The warnings are described at the end of the programming section..

| Bit | Warning |
|-----|-------------------------|
| 0 | Current limit |
| 1 | No motor |
| 2 | Reference fault |
| 3 | Motor overloaded |
| 4 | Inverter overloaded |
| 5 | Frequency warning, low |
| 6 | Frequency warning, high |
| 7 | Current warning, low |
| 8 | Current warning, high |
| 9 | EEPROM fault |
| 10 | 24 V fault |
| 11 | Overcurrent |
| 12 | Voltage warning, high |
| 13 | Voltage warning, low |
| 14 | Overvoltage |
| 15 | Undervoltage |

Index 16:

A decimal value which is to be converted to a 16-bit binary number. Each bit represents a control command. When a control command has been activated, the corresponding bit has the value "1".

Index 17:

A decimal value which is to be converted to a 16-bit binary number. Each bit represents a status message. When a status message is present, the corresponding bit has the value "1".

Index 18:

A decimal value which is to be converted to a 16-bit binary number. Each bit represents an alarm. When an alarm is present, the corresponding bit has the value "1".

| Bit | Alarm |
|-----|-----------------------------------------------------------|
| 0 | Trip locked |
| 1 | Control card or option card fault |
| 2 | Current limit |
| 3 | Not in use |
| 4 | Not in use |
| 5 | Auto-optimization |
| 6 | Motor overloaded |
| 7 | Inverter overloaded |
| 8 | Inverter fault |
| 9 | Undervoltage |
| 10 | Overvoltage |
| 11 | Overcurrent |
| 12 | Ground fault |
| 13 | Fault in DC supply |
| 14 | Overtemperature |
| 15 | Thermistor input activated, see parameter 400/terminal 16 |

★ = ROM default setting. ✓ = Normal Danfoss setup. Text in () = display text. Figures in [] are used when communicating with the bus.

| 503 Coasting (COAST) | |
|----------------------|-----|
| Value: | |
| Digital (DIGITAL) | [0] |
| Bus (BUS) | [1] |
| Logical and (AND) | [2] |
| ★ Logical or (OR) | [3] |

| 504 Quick-Stop (Q-STOP) | |
|-------------------------|-----|
| Value: | |
| Digital (DIGITAL) | [0] |
| Bus (BUS) | [1] |
| Logical and (AND) | [2] |
| ★ Logical or (OR) | [3] |

| 505 DC Brake (DC-BRAKE) | |
|-------------------------|-----|
| Value: | |
| Digital (DIGITAL) | [0] |
| Bus (BUS) | [1] |
| Logical and (AND) | [2] |
| ★ Logical or (OR) | [3] |

| 506 Start (START) | |
|-------------------|-----|
| Value: | |
| Digital (DIGITAL) | [0] |
| Bus (BUS) | [1] |
| Logical and (AND) | [2] |
| ★ Logical or (OR) | [3] |

| 507 Direction of Rotation (DIRECTION) | |
|---------------------------------------|-----|
| Value: | |
| ★ Digital (DIGITAL) | [0] |
| Bus (BUS) | [1] |
| Logical and (AND) | [2] |
| Logical or (OR) | [3] |

| 508 Reset (RESET) | |
|-------------------|-----|
| Value: | |
| Digital (DIGITAL) | [0] |
| Bus (BUS) | [1] |
| Logical and (AND) | [2] |
| ★ Logical or (OR) | [3] |

| 509 Selection of Setup (SETUP SELE) | |
|-------------------------------------|-----|
| Value: | |
| Digital (DIGITAL) | [0] |
| Bus (BUS) | [1] |
| Logical and (AND) | [2] |
| ★ Logical or (OR) | [3] |

| 510 Selection of Speed (SPEED SELECT) | |
|---------------------------------------|-----|
| Value: | |
| Digital (DIGITAL) | [0] |
| Bus (BUS) | [1] |
| Logical and (AND) | [2] |
| ★ Logical or (OR) | [3] |

Function (parameters 503 through 510):

These parameters are used for determining how control commands from serial bus communication are to be prioritized in relation to the same control commands from the digital inputs.

Description of choice (parameters 503 through 510):

Digital is selected if the control command is only to be activated via a digital input.

Bus is selected if the control command is only to be activated by means of serial bus communication.

Logical and is selected if the control command is only to be activated when the signal is active from both the serial bus and the digital input. Active signal "1".

Logical or is selected if the control command in question is to be activated when the signal is active from either the control word or the digital input. Active signal "1".



NOTE:

Parameters 503 through 505 concern stop functions - see example concerning parameter 503, coasting, on next page. Active stop signal is "0".

510 Selection of Speed (SPEED SELECT) continued

Parameter 503 = *Logical and*

| Digital input | Control word | Control command |
|---------------|--------------|-----------------|
| 0 | 0 | Coasting |
| 0 | 1 | Motor running |
| 1 | 0 | Motor running |
| 1 | 1 | Motor running |

Parameter 503 = *Logical or*

| Digital input | Control word | Control command |
|---------------|--------------|-----------------|
| 0 | 0 | Coasting |
| 0 | 1 | Coasting |
| 1 | 0 | Coasting |
| 1 | 1 | Motor running |

511 Bus Jogging 1 (BUS JOG 1)

Value:

000.0 - f_{RANGE} ★ 10.0

512 Bus Jogging 2 (BUS JOG 2)

Value:

000.0 - f_{RANGE} ★ 10.0

Function:

Choose two fixed jog speeds, in Hz for Bus Jog 1 and Bus Jog 2. They are similar to the jog frequency of parameter 203. Bus jog 1 and 2 can only be activated via serial bus communication.

Bus Jog only works when parameter 497 is set for Quick Stop and voltage is applied to terminal 27.

513 Catch-up/Slow-down Value (CATCHup/SL)

Value:

0 to 100% ★ 0

Function:

The output frequency of the drive can be reduced or increased by the value selected here; the value is set as a percentage of the output frequency at any given time

514 Bus Bit 4 (BUS BIT 4)

Value:

- ★ Quick-stop (Q-STOP) [0]
- DC braking (DC BRAKE) [1]

Function:

Bit 4 of the control word can be used either for quick-stop, or for DC braking.

515 Bus Bit 11/12 (BUS BIT 11)

Value:

- ★ Catch-up/slow-down (CATCH" SLOW) [0]
- Choice of digital reference (DIG SPD TYPE) [1]

Function:

Bits 11/12 of the control word can be used either for the "catch-up/slow-down" function, or for selecting between the digital speed references defined by parameters 205 through 208 in the same way that terminals 32 and 33 can be used to select a digital reference.

516 Bus Reference (BUS REFERE)

Value:

-100.00% - +100.00% ★ 0.00

Function:

Used for changing the drive's reference. It is entered as a % of f_{MAX} . It is sent as a part of a serial command message as follows:

Parameter no.: 516 bytes 9-12
 Data: Required ref. bytes 13-18
 Decimal point: Position byte 19

517 Save Data Values (STORE DATA)

Value:

- ★ Off (OFF) [0]
- On (ON) [1]

Function:

Data values that are changed via serial bus communication are not saved automatically if the AC power is removed. Parameter 517 must be used if modified data values are to be saved.

Description of choice:

If *On* is selected, it takes approximately 10 seconds to save all data values of the parameters; parameter 517 subsequently assumes the value of *Off*. Only the data values of the active menu setup are saved. Each setup must be saved separately if changes have been made.



NOTE:

The saving function can only be activated when the drive has stopped.

★ = ROM default setting. ✓ = Normal Danfoss setup. Text in () = display text. Figures in [] are used when communicating with the bus.

Group 600 -- Service and Diagnostics

600 Operation Data (OPERATION)

Value:

- ★ 0 Total number of operating hours (TOT.HRS xxxx.x) *)
- 1 Running hours (RUN.HRS xxxx.x)*)
- 2 kWh (ENERGY xxxx.x)
- 3 Number of power ups (POW.UPS xxxxx)
- 4 Number of overheatings (OV.TEMP xxxxx)
- 5 Number of overvoltages (OV.VOLT xxxxx)

Function:

[Index 000.00-005.00]

Display of the selected operation data.

Description of choice:

Display range:

Total number of operating hours, running hours, and kWh is 0.0 to 99,999 (below 10,000, with 1 decimal).

Number of power ups, number of overheatings, and number of overvoltages is 0 to 99,999.

Total number of operating hours, running hours, and kWh is automatically reset after manual initialization. kWh can be reset via parameter 011. Running hours can be reset via parameter 012.

NOTE:



The data stated are saved every 8 hours. Number of power ups, number of overheatings, and number of overvoltages are saved as they occur.

601 Data Log (DATALOG)

0 1 2 3 4 - -19

- Digital inputs (DIG.IN) [0]
- Control word (CONTRL)[1]
- Status word (STATUS) [2]
- Reference % (REF. %) [3]
- Frequency out (F-OUT) [4]
- Phase current (IPHASE) [5]
- DC voltage (UDC) [6]

Function:

[Index 000.00 - 019.06]

Log data for the last 3.2 seconds of operation before a stop or a fault. The “+” and “-” keys can be used to cycle through the display values and the 20 saved data sets. The data set number is displayed on the far right of the display’s third line.

Description of choice:

Digital inputs are stated in hex code (0-FF).

Control words are stated as a hex code (0-FFFF) for bus operation RS 485.

Status words are stated as a hex code (0-FFFF) for bus operation RS 485.

Reference is the control signal in percent (0 to 100%).

Frequency out is the output frequency of the drive in Hz (0.0 to 999.9).

Phase current is the output current in A (0.0 to 999.9).

DC voltage indicates the voltage of the drive’s DC bus in V DC (0 to 999).

Twenty logged values are saved (0 to 19). The lowest number (0) contains the most recent/last data value saved, the highest log number (19) contains the oldest data value. Data values log every 160 msec. as long as the start signal is active. The data log contains the 20 last log values (approx. 3.2 sec.) before a stop signal is given (start not active), or a trip occurs. It is possible to scroll through the log values.



NOTE:

The data log is reset during power up.

602 Alarm Store (ALARM MEMO)

| | 0 | 1 | 2 | 3 | -- | 7 |
|-------------------|-----|---|---|---|----|---|
| Fault code (CODE) | [0] | | | | | |
| Time (TIME) | [1] | | | | | |
| Value (VALUE) | [2] | | | | | |

Function:

[Index 000.00 to 007.02]. Storage of data in connection with tripping. The "+" and "-" keys can be used to cycle through the display values and the eight saved data sets. The data set number is displayed on the far right of the display's third line.

Description of choice:

The fault code gives the cause of a tripping incident in the form of a digit code from 1 to 15:

| Fault code | Fault |
|------------|-----------------------------------|
| 1 | Alarm |
| 2 | Overvoltage |
| 3 | Undervoltage |
| 4 | Overcurrent |
| 5 | Ground fault |
| 6 | Overtemperature |
| 7 | Inverter overloaded |
| 8 | Motor overloaded |
| 9 | Current limit |
| 10 | Trip locked |
| 11 | Control card or option card fault |
| 13 | Auto-optimization fault |
| 14 | Fault in the DC supply |
| 15 | Thermistor input activated |

Time indicates the value of the total number of operating hours when the trip occurred. Display range 0.0 to 999.9.
Value indicates at what voltage or current the trip occurred. Display range 0.0 to 999.9.

When serial communication is used, the fault code is returned in the form of a whole number. Time and value are returned in the form of floating decimal point values.

Eight events are logged, numbered from 0 to 7. The lowest log number, 0, contains the most recent event, the highest log number, 7, contains the oldest event.

An alarm can only be represented once. The fault log is reset after manual initialization. Regardless of the log set being studied at any given time, the display automatically switches to log number 0 if another trip occurs.

603 Nameplate (NAMEPLATE)
Value:

| | |
|------------------------|-----|
| ★ 0 Type (VLT3xxx) | |
| 1 Unit voltage (xxx V) | |
| 2 Software type | |
| HVAC | [1] |
| Series | [2] |
| Profibus Proc | [3] |
| Profibus Series | [4] |
| Synchron Opt | [5] |
| Modbus+ Proc | [6] |
| Modbus Series | [7] |

3 Software version (V x.xx)

Function:

The key data for the unit can be read from the display or the serial bus.

Description of choice:

Type indicates the size of unit and the basic functions involved.

Unit voltage indicates the voltage range of the unit

200 V = 200 through 230 V

380 V = 380 through 410 V

460 V = 440 through 500 V

Software type indicates whether the software used is a standard product or specially developed.

Software version indicates the version number.

604 Operation Mode (OPERATION)

Value:

- ★ Normal operation (RUN NORMAL) [0]
 - Operation with deactivated inverter (RUN INV DISABL) [1]
 - Control card test (CTRL CARD TEST) [2]
 - Initialization (INITIALIZE) [3]

Function:

In addition to its normal function, this parameter can be used for two different tests. In addition, initialization of all parameters except parameters 500, 501, 600 and 602 can be done.

Description of choice:

Normal operation [0] is used for normal running of the motor.

Operation with deactivated inverter [1] is selected to allow the control card to be operated without activating the inverter. The effect of changes in the control signal on the control card and its functions can be seen without the inverter driving the motor.

Control card test [2] is selected if testing of the control card; analog and digital inputs; analog, digital and relay outputs; and its control voltage of +10 V is required. This test requires the use of a test connector with connections as shown in the drawing. This connector is referred to as the "RAIL" in the on-screen instructions.

To run the control card test, proceed as follows:

- 1) Press the stop key.
- 2) Insert the test connectors in the plugs on the control card.
- 3) Choose control card test from parameter 604.
- 4) Disconnect power and wait for the light on the display to go out.
- 5) Reapply power.
- 6) Press the start key.

The test will take about two minutes. The test will go through three steps, each of which gives an OK or fault message, depending on the result. If a fault message appears, the control card must be replaced.

Initialization [3] is selected if factory setting of the unit is required without resetting of parameters 500, 501, 600 and 602.

Procedure:

- 1) Select initialization.
- 2) Press the "Menu" key.
- 3) Remove AC power and wait for the light in the display to go out.
- 4) Reapply power.

Test Connector

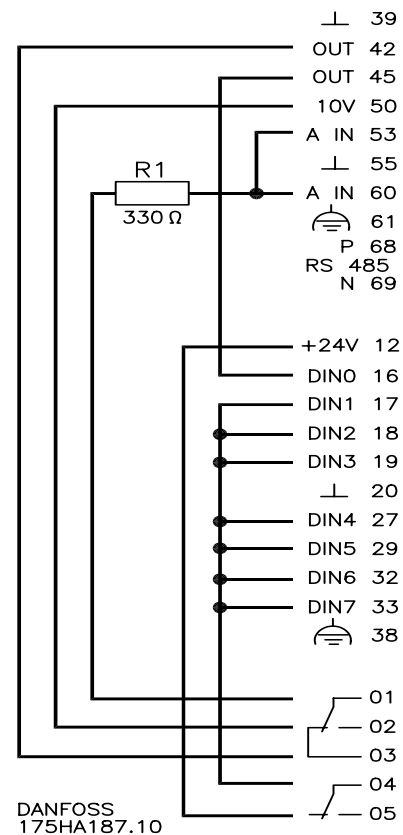

Following the drawing above, a test connector can be built using a set of the control terminal connectors, a 330 Ω resistor, and wire.

605 Dual Function Display Select (DISPLAY SE)

Value:

| | |
|--------------------------------------------|------|
| ★ Standard display (STANDARD DISP) | [0] |
| Reference % (REFERENCE %) | [1] |
| Frequency Hz (FREQUENCY Hz) | [2] |
| Feedback unit (FEEDBK 'UNIT') | [3] |
| Current A (CURRENT A) | [4] |
| Torque % (TORQUE %) | [5] |
| Power kW (POWER kW) | [6] |
| HP power (POWER HP) | [7] |
| Energy kWh (ENERGY kWh) | [8] |
| Output voltage V (OUTPUT VOLT.V) | [9] |
| DC voltage (DC BUS V) | [10] |
| VLT therm % (ETR (VLT) %) | [11] |
| Motor therm % (ETR (MOT) %) | [12] |
| Running hours (RUN HOURS) | [13] |
| Input status "binary code" (DIGITAL INPUT) | [14] |

Function:

The display can show two data values at the same time. The value chosen here is shown in line 2 on the display.

Description of choice:

Standard display [0] is chosen if normal reading is desired. For example, when Hz is shown in line 1, line 2 will show "Frequency" and the operating mode will be shown in line 3.

Dual function display select. One of the other fourteen data values above is selected if a different operating value is to be displayed in line 2. For example frequency can be shown in line 1 and current shown in line 2 at the same time.



NOTE:

To view both lines at the same time, the display must be in Display mode. To enter the Display mode from any other mode, press "Menu" and "Data" simultaneously.

606 Display Mode (DISPLAY MO)

Value:

| | |
|------------------------------------|-----|
| ★ Standard display (QUICK DISPLAY) | [0] |
| Extended display (EXT. DISPLAY) | [1] |

Function:

Choose between two different Display Modes. Extended display allows the operator to cycle through a wide range of data types. See the section on Display Mode.

650 VLT Type (VLT TYPE)

Function:

Used for indicating the unit in which the control card is placed, in cases where the control card is not able to determine this itself. Or used for choosing the voltage range in multi-voltage units whose factory setting varies from that required.

Description of choice:

This parameter is used for choosing the right VLT type/size/voltage. The power board will identify itself to the control, and in most cases the proper type/size/voltage will automatically be selected when power is applied to the drive.

VLT Types 3575 through 3800 are multi-voltage units. It is important that the line voltage be set correctly by this parameter. If the factory-set voltage does not correspond to the line voltage of the application for which the unit is intended, proceed as follows:

- 1) Select the desired VLT type/size/voltage.
- 2) Select parameter 604, data value initialization.
- 3) Remove AC power and wait for the light in the display to go out.
- 4) Reapply AC power.



NOTE:

When reapplying power, check the display to see that the new data is shown.

Status Messages

Status messages appear in the third line of the display



Status messages

List of Common Status Messages

The following status messages will commonly be seen. They are described below. To view the status message line enter the display mode by simultaneously pressing “Menu” and “Data”.

Local Stop (STOP LOCAL):

“Keypad” or “Keypad with external stop” has been selected in parameter 003. The “Local/Hand” key and the “Stop” key on the keyboard are activated.

VLT ready, local (UNIT RDY LOC.):

“Keypad with external stop” has been selected in parameter 003, “Mtr. Coast” has been selected in parameter 404. The “Local/Hand” key on the drive operating panel is activated. This indicates that the drive is ready to run in local mode, but is not running because the circuit to terminal 27 (external interlock) is open.

Local operation OK (RUN OK LOCAL):

“Keypad” or “Keypad with external stop” has been selected in parameter 003. The “Local/Hand” key on the drive operating panel is activated and the drive is running on the local reference.

Local ramp operation (RAMP LOCAL):

“Keypad” or “Keypad with external stop” has been selected in parameter 003. The “Local/Hand” key on the drive operating panel is activated and the drive is either accelerating or decelerating.

Stop (STOP REMOTE):

Remote Control mode, “Remote/Auto”, is active and the drive has been stopped via the keyboard or the control terminals.

VLT ready (UNIT READY):

Remote Control mode, “Remote/Auto” is active and “Coasting Stop” has been selected in parameter 404; there is no voltage on terminal 27.

Operation OK (RUN OK.):

Remote Control mode, “Remote/Auto”, is active and the drive is running on the speed reference.

Jogging (JOG REMOTE):

Remote Control mode, “Remote/Auto”, is active and “Jogging” has been selected in parameter 405, and there is 24 V on terminal 29.

Ramping (RAMPING):

Remote Control mode, “Remote/Auto”, is active and the drive is either accelerating or decelerating.

Freeze Reference (FREEZE):

Remote Control mode, “Remote/Auto”, is active and “Freeze Reference” has been selected in parameter 400, 401 or 405 and there is an input on terminals 16, 17 and/or 29. The drive will stay at the present speed reference until the voltage to the “freeze” terminal is removed.

Off 2 (OFF 2):

Bit 01 of the serial control word is “0”.

Off 3 (OFF 3):

Bit 02 of the serial control word is “0”.

Start Disabled (START INHIB.):

Bit 06 of the serial status word is “1”.

Reference Locked (HOLD.):

Bit 05 of the serial control word is “0”.

Warning Messages

Warning messages also appear in the third line of the display.

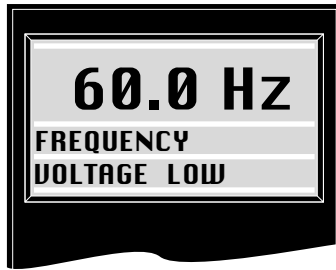

Warning messages

List of Common Warning Messages

The following warnings may be seen. They are listed below with an explanation of the cause of the problem.

Low Voltage Warning (VOLTAGE LOW):

The DC bus voltage is below the warning limit. The inverter is still operating.

High Voltage Warning (VOLTAGE HIGH):

The DC bus voltage is above the warning limit. The inverter is still operating.

Undervoltage (UNDER VOLTAGE):

The DC bus voltage is below the undervoltage limit of the inverter. The inverter has stopped and a fault trip will follow after the time delay selected in parameter 311. See the table below.

Overvoltage (OVER VOLTAGE):

The DC bus voltage is above the overvoltage limit of the inverter. The inverter has stopped and a trip will follow when the delay selected in parameter 311 has passed. See the table below.

Current Limit (CURRENT LIMIT):

The motor current is higher than the value entered in parameter 209, Current Limit. A fault trip will follow after the time delay selected in parameter 310.

Overcurrent (OVER CURRENT):

The peak current limit of the inverter (approximately 250% of the rated current) has been exceeded. After 7 to 11 seconds a fault trip will follow.

Reference Fault (REF FAULT):

An analog input signal with a “live zero” has been chosen such as 4 to 20 mA, 1 to 5 V or 2 to 10 V, for terminal 53 or 60. The warning is activated when the signal level is below half the minimum level.

No Motor (NO MOTOR):

The motor check function in parameter 313 detects that no motor has been connected to the drive's output.

Low Frequency Warning (LO FREQ WARN):

The output frequency is lower than the value selected in parameter 210.

High Frequency Warning (HI FREQ WARN):

The output frequency is higher than the value selected in parameter 211.

Low Current Warning (LO CURR WARN):

The output current is lower than the value selected in parameter 212.

High Current Warning (HI CURR WARN):

The output current is higher than the value selected in parameter 213.

Motor Overloaded (MOTOR TIME):

According to the motor electronic thermal relay protection (ETR), the motor is too hot. Parameter 315 must be set to give a warning.

Inverter Overloaded (INVERT TIME):

According to the drive's electronic thermal protection, the drive is close to tripping because of overload (too high a current for too long a time). The counter for drive electronic thermal protection has reached 98%, 100% results in a trip.

24 V Fault (NO 24 VOLT):

The 24 V DC supply to the control card is not present.

EEPROM Fault (EEPROM ERROR):

EEPROM fault. Data changes are not saved when AC power is removed.

| | VOLTAGE LIMITS | | | | | | | |
|-------------------------|-------------------|----------|-------------------|----------|-------------------|----------|--------------------|----------|
| | 200 through 230 V | | 380 through 415 V | | 440 through 500 V | | all Type 3575-3800 | |
| Drive input voltage | DC Bus | AC Input | DC Bus | AC Input | DC Bus | AC Input | DC Bus | AC Input |
| Undervoltage fault trip | 210 | 150 | 400 | 285 | 460 | 325 | 470 | 330 |
| Voltage warning, low | 235 | 170 | 440 | 310 | 510 | 360 | 480 | 340 |
| Voltage warning, high | 370 | 260 | 665 | 470 | 800 | 565 | 790 | 560 |
| Overvoltage fault trip | 410 | 290 | 730 | 515 | 880 | 620 | 850 | 600 |

Reset Messages

Reset messages appear in the second line of the display.

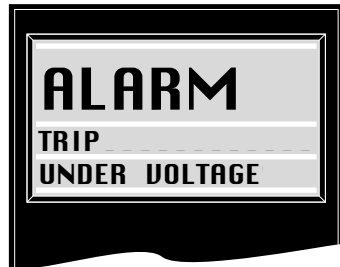

Reset messages

Alarm messages

Automatic Restart (RESTART):

When “automatic reset” has been selected in parameter 309, this message indicates that the drive is trying to restart automatically after having tripped. The time delay before the restart is set by parameter 312.

Trip (TRIP):

The drive has tripped and manual resetting has been selected by parameter 309. Manual resetting can be carried out by means of the reset key on the keyboard, a digital input to terminal 16, 17 or 27, or through the serial interface.

Trip Locked (TRIP LOCKED):

The drive has tripped and resetting is only possible by removing and reapplying AC power, and then resetting as in Trip, above. A trip lock fault is considered serious and the cause of the fault should be corrected before resetting.

Alarm Messages

Alarm messages appear in the third line of the display and describe the reason for the fault trip.

Undervoltage (UNDER VOLTAGE):

Error code 3

The DC bus voltage is below the undervoltage limit of the drive, see the table on the previous page.

Overvoltage (OVER VOLTAGE):

Error code 2

The DC bus voltage is above the overvoltage limit of the drive, see the table on the previous page.

Current Limit (CURRENT LIMIT):

Error code 9

The motor current has exceeded the value of parameter 209 for a longer time than that permitted in parameter 310.

Overcurrent (OVER CURRENT):

Error code 4

The peak current limit of the inverter, approximately 250% of the rated current, has been exceeded for more than 7 to 11 secs. This causes a Trip Locked fault.

Ground Fault (GROUND FAULT):

Error code 5

There is a current path from the output phases to the ground, either in the wiring between the drive and the motor, or within the motor. This causes a Trip Locked fault.

Overtemperature (OVER TEMP):

Error code 6

Too high a temperature has been measured within the drive. A cool-down period is required before resetting is possible. This causes a Trip Locked fault.

Inverter Overloaded (OVERLOAD):

Error code 7

The electronic thermal inverter protection reports that the drive has tripped because of overload (too high a current for too long). The counter for electronic thermal inverter protection has reached 100%.

Motor Overloaded (MOTOR TRIP):

Error codes 8 and 15

The motor electronic thermal relay (ETR) protection reports that the motor is too hot. “Trip” must be selected in parameter 315 for this alarm to activate.

Inverter Fault (INVERT FAULT):

Error code 1

There is a fault on the power side of the drive.

Fault Messages

The fault messages listed below are shown on the third line of the display and indicate that a prohibited change is being attempted.

The display will show **KEY DISABLED** if an attempt is made to change a parameter when Factory Setup had been selected in parameter 001. Change to setup 1, 2, 3, or 4 to change the parameters.

If the display reads **ONLY IN STOP** when an attempt is made to change data, this means that the function cannot be changed with the drive running. Press Stop/Reset and then change the parameter.

If the display reads **LOCK OPEN** when an attempt is made to change a parameter, the mechanical keypad lockout is open. Switch pin 01 must be closed before any parameter is changed.

If the display reads **LIMIT** when a parameter is being changed, it means one end of the permissible range has been reached.

Start-up Test (CONTROL CARD FAULT)

The drive carries out a self-test of the control card whenever the AC power is applied. The following message may appear:



This message indicates a control card problem. Contact a Danfoss service center.

The following faults indicate an operational problem that caused the Inverter to fault trip to protect itself or the motor from possible damage. The cause of the fault must be found and eliminated.

Inverter Fault

The power section of the drive is defective.

Overvoltage

The voltage in the DC bus is too high. Possible causes include:

- Input voltage too high
- Transients on the input
- Regenerative motor operation

NOTE: When the drive decelerates, energy from the motor is returned to the drive (regenerative operation), which charges the intermediate circuit. If this is the cause of the overvoltage fault, the ramp time can be extended using parameters 216 and 218 until the fault does not occur.

Undervoltage

The voltage of the DC bus is too low. Possible causes include:

- Input voltage too low
 - Failure of the charging circuit/rectifier of the drive
- Before calling for service, check the input line voltage.

Overcurrent

This fault indicates that upper limit of the rectifier peak current has been exceeded, possibly because of a short circuit in the output of the drive.

Before calling for service, check for an output short circuit.

Ground Fault

This indicates a ground fault on the drive's output. Check motor and motor wiring for ground fault problems.

It is also possible that the motor wiring is too long. Motor wiring should always be as short as possible, and never over 1,000 feet long. Reducing the output carrier frequency down to 4.5 kHz or lower may eliminate a ground fault problem caused by excessive motor lead length.

Critical Temperature

The temperature inside drive is too high. Possible causes include:

- Ambient temperature is above 104°F, (40 °C)
- The heat sink of the drive is dirty or obstructed
- The fan(s) is not operating
- The drive is not mounted vertically directly against a solid surface

Overload

The electronic thermal overload protection has tripped the drive. This means that the motor has consumed more than 110% of the rated current of the drive for too long. Reduce the motor load. If this is not possible, the application may require a larger drive. Be sure that the motor is not also overloaded before installing a larger drive.

Motor Trip

The motor electronic thermal relay (ETR) protection is active. This means that the current consumed by the motor at low speed has been too high for too long. It indicates that the motor has been loaded excessively at low speed. Try to reduce the load at low speed or make the motor run at a higher speed. If this not possible, the motor must be replaced with a larger one or extra cooling must be provided for the existing motor. The electronic motor protection can be turned off in parameter 315, but at the risk of burning up the motor. If a thermostat or thermistor is installed in the motor's windings, this can be used to provide motor thermal protection by setting parameter 400 to thermistor and wiring the thermostat or thermistor between terminals 50 and 16.

⚠WARNING

Turning off the electronic thermal motor protection will prevent the drive from monitoring motor temperature. The motor may overheat.

Electrostatic Discharges

⚠WARNING

Many electronic components are sensitive to static electricity. Even voltages so low that they cannot be felt, seen or heard may damage components or destroy them completely.

Discharge of static electricity can damage components, shorten their life, and cause erratic operation. Suspect damage due to static electricity if faults occur periodically with varying temperature, varying load, or vibration.

When performing field service on the VLT Series 3500 drives, the following precautions must be taken:

- A portable ESD service kit, consisting of a metal wrist strap and a conductive mat, must be used.
- The portable ESD field service kit must be connected to the same potential as the drive chassis.
- Replaced, defective control cards must be placed in antistatic packing. The packing from the new card may be used for this purpose.

Troubleshooting

The Troubleshooting Flowcharts on the next pages are based on the most common problems.

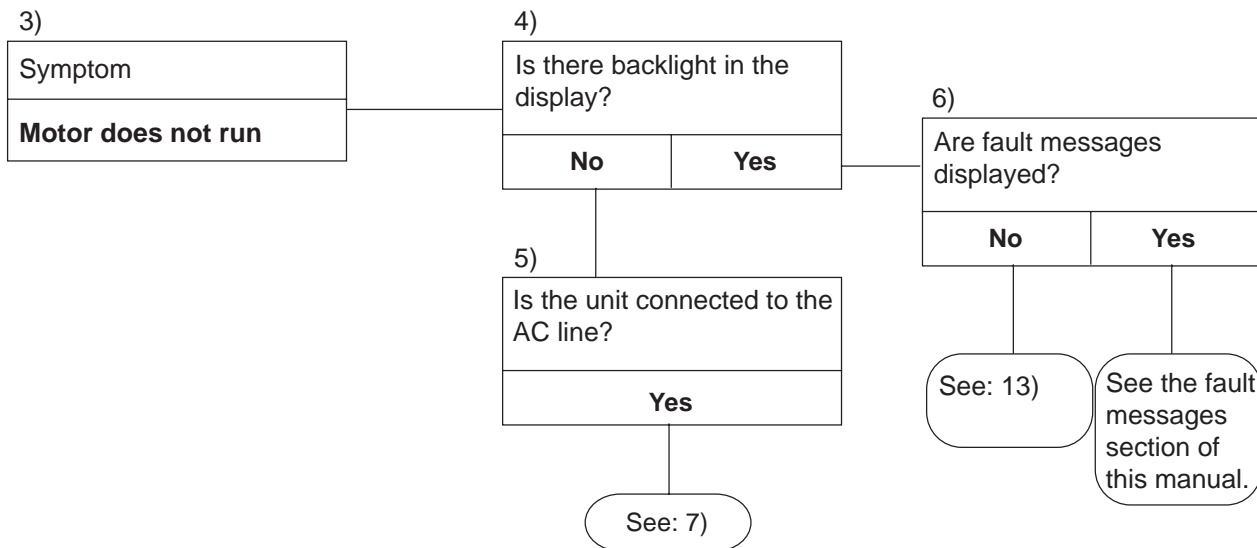
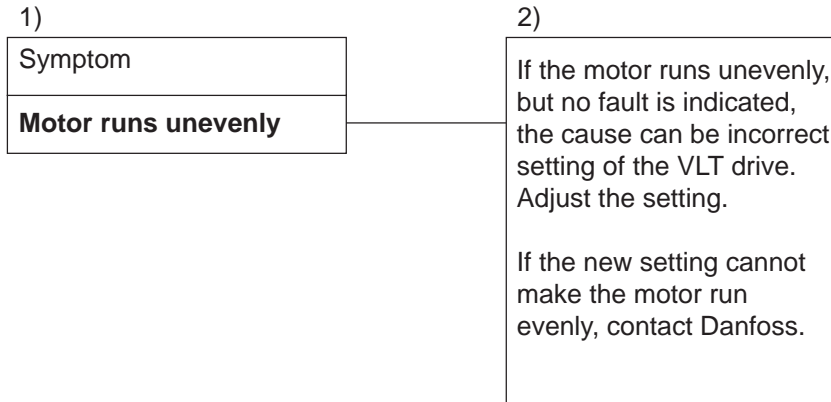

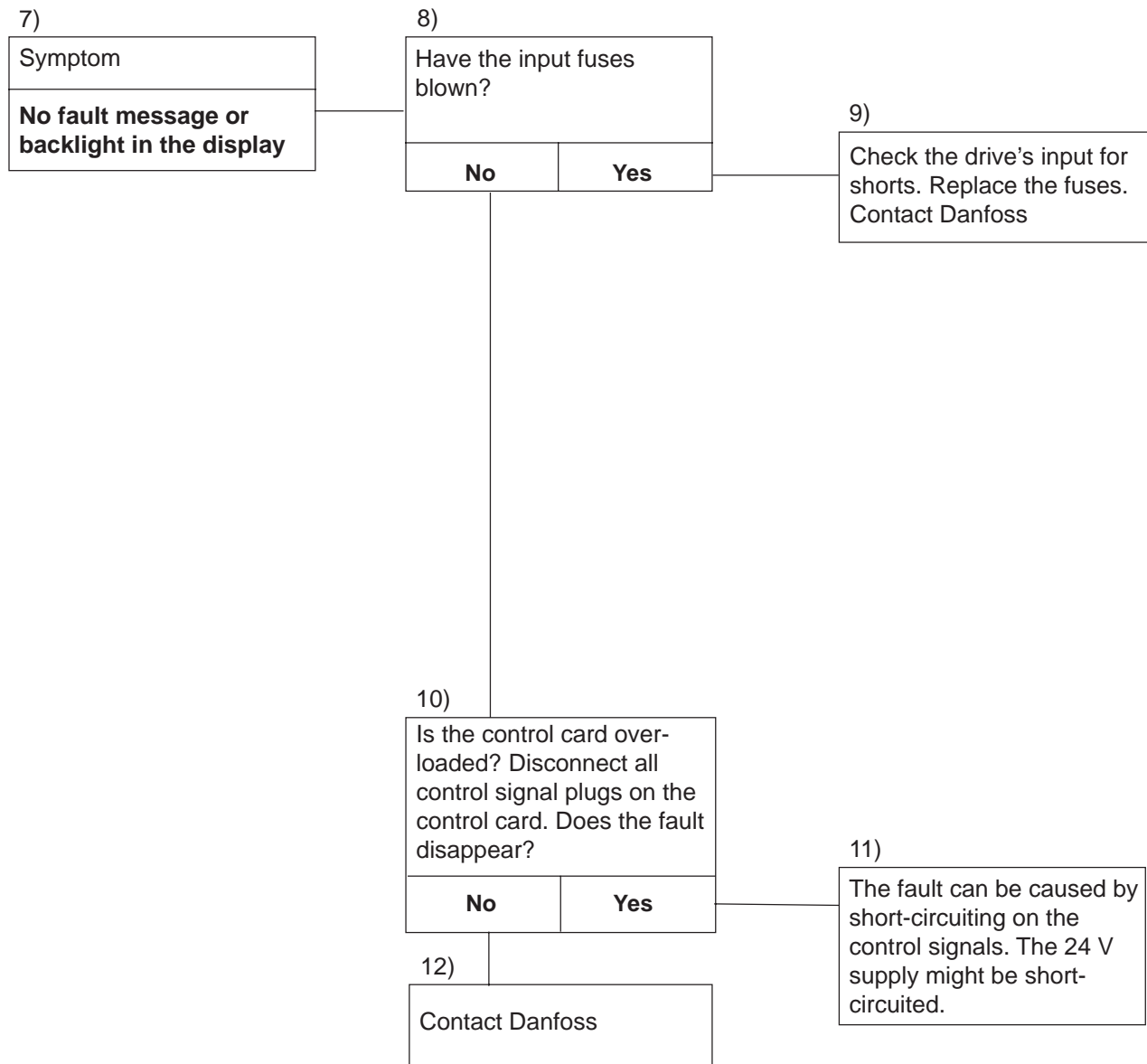

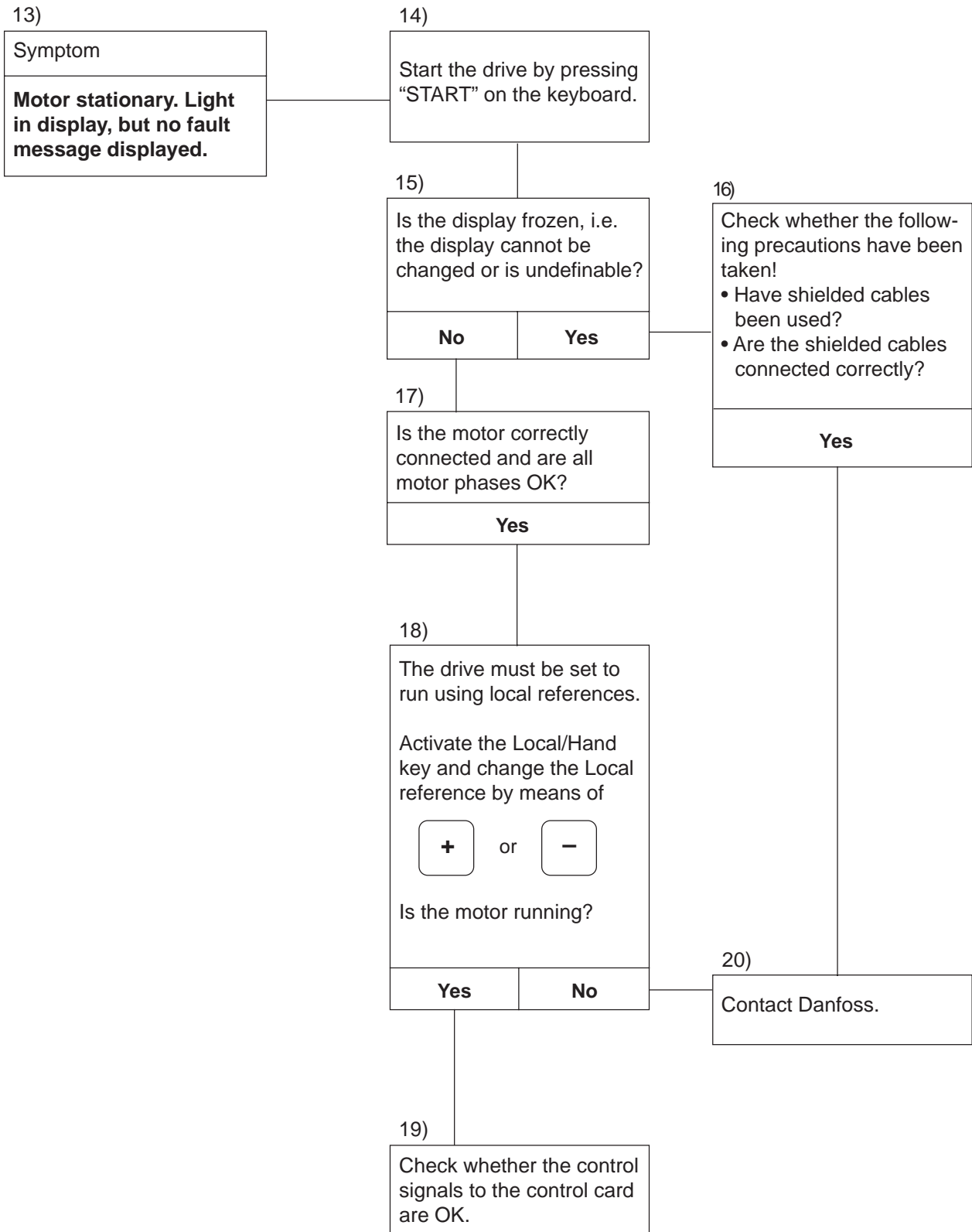

⚠ DANGER

Before opening the enclosure to install any components, be sure all power has been removed from the drive. Allow at least 14 minutes for the capacitors to discharge before touching any internal components.

External Mounting of Display

The control panel can be mounted remotely by means of an optional adapter and cable. The cable is 10 feet long. Longer cables are not recommended.

The control panel and its mounting surfaces meet the requirements for NEMA 12. The hole size required is 4.41 x 2.01 ± 0.02 inch.

Installation of Option Cards

There is a provision to mount an option card next to the control card in the drive. Mount the option card using the groove in the right-hand side of the aluminium tray and the two screws provided with the card, if not factory installed.

The electrical connections between the option card and the standard control card is through plugs FK1 through FK4.

Mounting of Optional Fan

Some applications may have an optional fan that must be installed, if it is not factory installed.

To install the fan, unplug the ribbon connector and the small cable and the ground wire from the control card.

Remove the control card and the shield behind it.

Position the fan on the aluminum extrusion, making sure that the fan mounting holes are aligned with the enclosure.

Plug the fan connector into the matching connector on the power board.

Reinstall the control card carefully. Plug in the ribbon connector, the small cable and the ground wire.

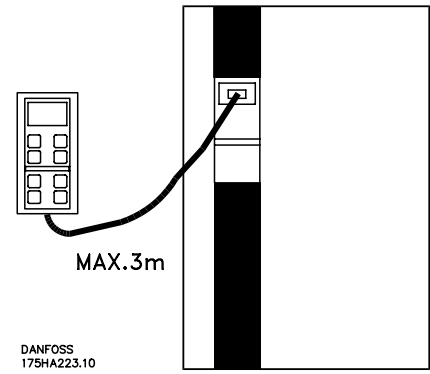

DANFOSS
175HA223.10

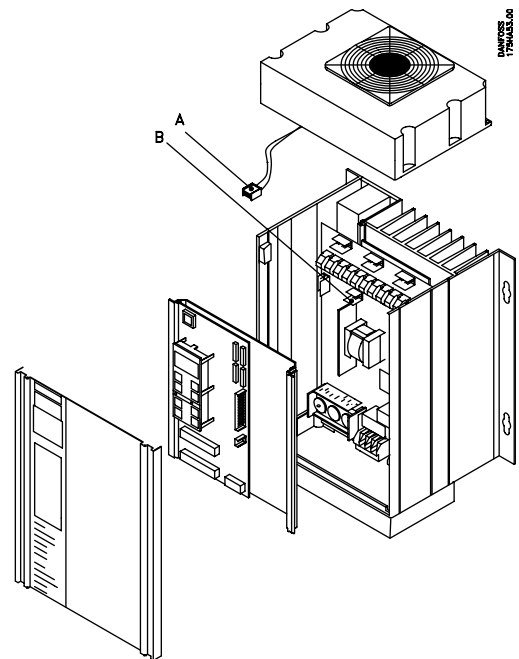
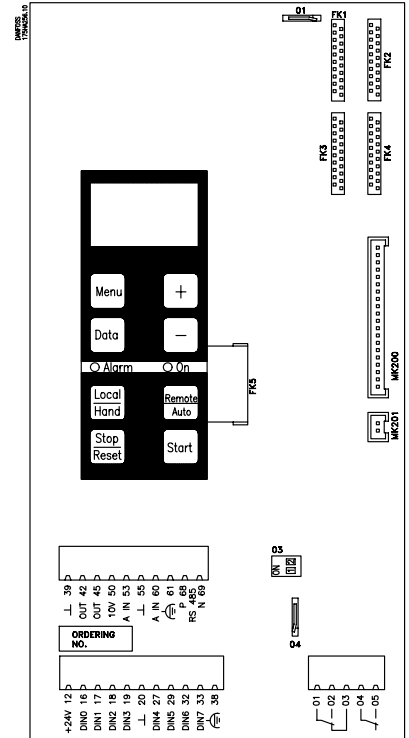

Appendix 1
Field Terminal Connections

All of the bolts on the field terminal blocks and other devices must be torqued according to the tables below. All connections must be made with 75°C rated copper wiring.

All units are in inch pounds.

200-230 V Input

| Max. Drive Output Current | Overload | Terminal Block | Circuit Breaker | Disconnect or Transfer Switch | Main Fuse Block | Drive Fuse Block | Ground Terminal |
|---------------------------|----------|----------------|-----------------|-------------------------------|-----------------|------------------|-----------------|
| 5.4 | 15 | 15 | 35 | 35 | 20 | 35 | 45 |
| 5.7 | 15 | 15 | 35 | 35 | 20 | 35 | 45 |
| 7.5 | 15 | 15 | 35 | 35 | 25 | 35 | 45 |
| 10.6 | 15 | 15 | 35 | 35 | 25 | 35 | 45 |
| 16.7 | 15 | 35 | 35 | 35 | 25 | 45 | 45 |
| 24.8 | 15 | 50 | 35 | 35 | 45 | 45 | 45 |
| 32 | 15 | 50 | 35 | 50 | 120 | 45 | 45 |
| 46 | 75 | 50 | 35 | 50 | 120 | 45 | 45 |
| 61.2 | 75 | 275 | 100 | 50 | 120 | 45 | 50 |
| 74.8 | 120 | 275 | 100 | 375 | 120 | 275 | 50 |
| 88 | 120 | 275 | 100 | 375 | 120 | 275 | 50 |
| 104 | 120 | 50 | 150 | 375 | 275 | --- | 50 |
| 130 | 250 | 375 | 100 | 375 | 275 | --- | 150 |
| 154 | 375 | 375 | 275 | 375 | 275 | --- | 150 |

460 V Input

| Max. Drive Output Current | Overload | Terminal Block | Circuit Breaker | Disconnect or Transfer Switch | Main Fuse Block | Drive Fuse Block | Ground Terminal |
|---------------------------|----------|----------------|-----------------|-------------------------------|-----------------|------------------|-----------------|
| 1.8 | 15 | 15 | 35 | 35 | 20 | 35 | 45 |
| 2.6 | 15 | 15 | 35 | 35 | 20 | 35 | 45 |
| 3.4 | 15 | 15 | 35 | 35 | 20 | 35 | 45 |
| 4.8 | 15 | 15 | 35 | 35 | 20 | 35 | 45 |
| 8.2 | 15 | 15 | 35 | 35 | 20 | 35 | 45 |
| 12.6 | 15 | 15 | 35 | 35 | 25 | 35 | 45 |
| 14 | 15 | 15 | 35 | 35 | 25 | 35 | 45 |
| 21.8 | 75 | 15 | 35 | 35 | 25 | 35 | 45 |
| 27.9 | 75 | 35 | 100 | 35 | 45 | 45 | 45 |
| 34 | 75 | 35 | 100 | 50 | 45 | 45 | 45 |
| 41.6 | 75 | 50 | 100 | 50 | 45 | 45 | 45 |
| 54.2 | 75 | 50 | 100 | 50 | 120 | 45 | 50 |
| 65 | 75 | 50 | 100 | 50 | 120 | 120 | 50 |
| 78 | 75 | 50 | 100 | 375 | 120 | 275 | 50 |
| 96 | 120 | 50 | 150 | 375 | 275 | --- | 50 |
| 124 | 250 | 275 | 275 | 375 | 275 | --- | 120 |
| 156 | 275 | 275 | 275 | 375 | 275 | --- | 150 |
| 180 | 275 | 275 | 275 | 375 | 450 | --- | 150 |
| 240 | 275 | 275 | 275 | 500 | 450 | --- | 150 |
| 302 | 375 | 375 | 275 | 500 | 450 | --- | 150 |
| 361 | 375 | 375 | 275 | 375 | 375 | --- | 150 |

Appendix 2

The following instructions will enable quick and easy set-up of the PI regulation and associated parameter settings. Detailed information about each parameter can be found in the parameter section of this manual.

Parameter 100:

Set the load type. There are several choices in each group but **variable torque medium** or **variable torque medium with AEO** will suit most pumps or fans.

Parameter 101:

Select **closed loop** operation.

Parameter 114:

Choose the type of **feedback signal** the transmitter is using. The default value is **current** as it is the most widely used signal type.

Parameter 115 & 116:

Are used to scale a display read-out which is proportional to the feedback transmitter signal. The value is displayed only if **feedback** has been selected in display mode. To get to display mode from any other mode press MENU & DATA keys simultaneously.

If a transmitter has a range of 0-5 bar, 0 can be set in parameter 115 and 5 in parameter 116. In parameter 117 the unit **bar** can be programmed.

The default values are 0 & 100, to display 0-100%.

Parameter 117:

Choose the unit of measurement for scaling the feedback signal of the transmitter set in parameter 115 & 116. The default value is %.

Parameter 119:

The feed forward factor allows a part of the set-point signal to by-pass the PID regulator. This gives faster response when starting up a system where the integration time (parameter 122) is very long, and the system error is small.

Set at 0%. Only add 5% at a time, and only if the system takes a long time to start up. The drawing shows the influence of the feed forward.

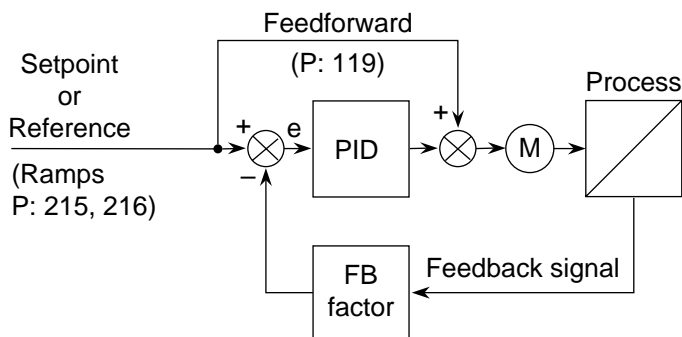

Parameter 120:

Controls the bandwidth of the output from PID controller.
Set at 100%.

Parameter 121:

Controls the gain of the system. For most fan and pump systems it should not be higher than 0.9. If set to higher values the system may become unstable.

- **Centrifugal fans - between 0.1 - 0.6**
- **Centrifugal pumps - between 0.3 - 0.8**

Parameter 122:

Improves the final accuracy by integrating out the error.

- **Centrifugal fans - between 10-12 seconds**
- **Centrifugal pumps - between 3-8 seconds**

Parameter 123:

Differential time is not used in pump and fan systems.
Set to Off.

Parameter 124:

If the feedback signal is fluctuating it can be dampened with a time constant. This can occur on pump systems where the pipe can be shut off quickly and cause a standing wave of water.

Set initially to 0 seconds.

Parameter 125:

Leave at the default value of 100% unless the following conditions occur.

- If the feedback signal does not match the standard analog signal choices in parameter 412 & 413 a value must be programmed which scales the feedback signal to a standard analog value.
- When using min. speed, parameter 201, it must be ensured that the min. speed % value is not greater than the set-point % value, otherwise the min. speed will over-ride the set-point.

(See example on page 112.)

Example:

The set-point is 40%, and the min. speed is 50%.

1. Selecting a new set-point. Choose a value that will raise the set-point about 10% higher than the min. speed.
New set-point = % min. speed x 1.1 = 55%
2. Setting parameter 125. Apply the same increase to this parameter. $100 \times 1.1 = 110\%$

Parameter 201:

Set min. frequency if required.

If you enter a min. speed you must observe the following:

- When min. speed is used parameter 411 must be set to "proportional with min. limit".
- If the min. frequency % is higher than the set-point % you must re-scale parameter 125 and the set-point.

Parameter 202:

Max. frequency is normally set to 50 Hz. Running centrifugal pumps and fans above this speed will cause overload of the pump or fan, as the power increases to the third power of the speed change.

Example:

If the speed increased to 60 Hz the power will increase by a massive 173%.

Set at 50 Hz.

Parameter 205:

The internal set-point for the regulator.

Enter the set-point % value.

Externally it can be one of the choices of the analog values. Use of one of the analog choices will prevent its use as the feedback signal.

The use of the internal set-point reduces installation costs. Up to 4 internal set-points (by using parameters 205-208) can be selected by a combination of 2 switches. Refer to the instruction manual for further information. The set-point can be found by calculating the percentage of required signal from the transmitter range.

Example:

A pressure transmitter has range of 0-10 bar. A set-point of 4 bar is required.

Set-point = $4/10 \times 100 = 40\%$

Enter 40 in parameter 205.

Parameter 214:

Use only linear ramps.

Parameter 215 & 216:

The ramps only function on starting and stopping the system.

Enter the ramp up and down times in seconds.

Parameter 315:

Set the motor thermal protection to **trip 1** if thermal protection of the motor is required.

Parameter 411:

This parameter must be changed from its default value when PID regulation is used.

Set to "proportional with min. limit".

Parameter 412-413:

Set the type of analog input signal for the set-point and feedback signals. Parameter 114 has previously set up the selection of the feedback signal type.

If parameter 205 (internal set-point) is used either current or voltage can be used as the feedback signal.

If one of the inputs is not used it must be set to no operation.

Normal or Inverse Control**Introduction:**

The control is called normal, if the motor speed is increased when the feedback signal goes down, and the motor speed is reduced if the feedback signal goes up. Typical for pump pressure systems and air handling units in variable air volume systems.

The control is called inverse if the motor speed is increased when the feedback signal is increased. Typical for pit pumping where: the faster the water flows into the pit, the faster the pump must pump out the water.

For inverse control; modification of the setpoint and feedback signal is required.

Example:

A transmitter has a 0-15 foot span equal to 0-20mA. The PID set-point must be set at 12 feet for inverse control.

- Enter 20-0 mA in parameter 413. The normal signal in figure A is converted to an inverse signal as shown in figure B.

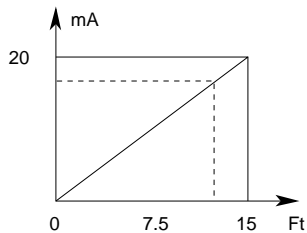

Figure A.
Normal signal from transmitter where 12 ft. represents 16mA (80%)

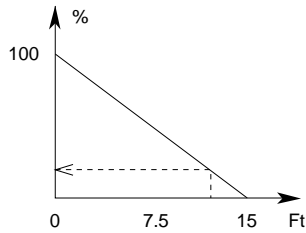

Figure B.
Inverted signal from par:413 where 12 ft. represents 100%-80%=20%

- Calculate the set point for inverse control.

$$\text{Setpoint} = 100 - (4/5 \times 100) = 20\%$$

It can be seen in figure C how the set point is calculated.

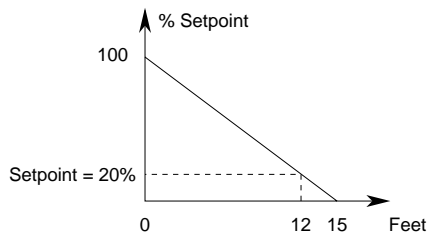
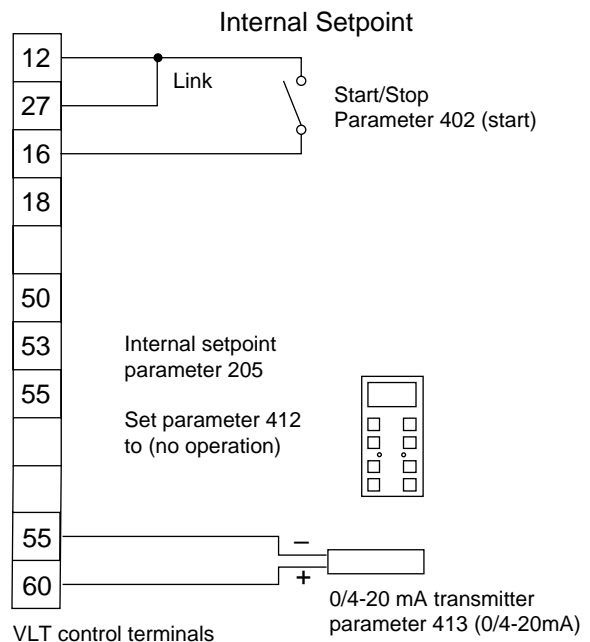
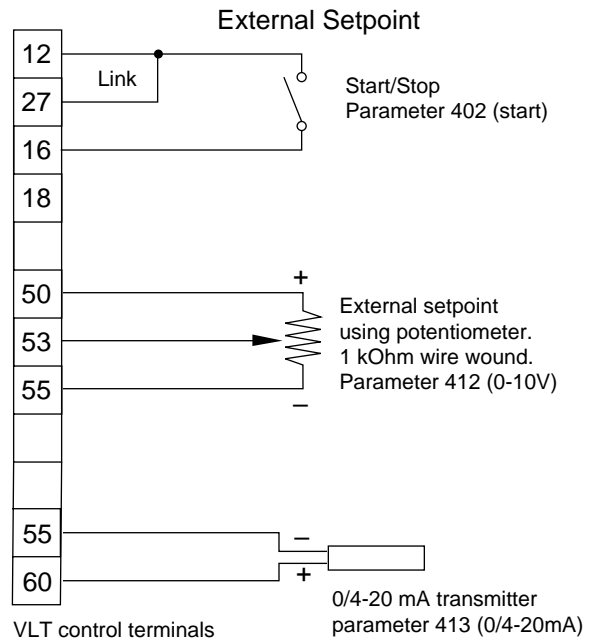

Figure C.
Inverted signal from par:413 (current) where 12 ft. represents 100%-80%=20%

- If the internal set-point is used, ensure that parameter 412 (voltage input) is set to **no operation**.
- The values in parameter 115 & 116 must be reversed. The display at min. feedback in parameter 115 becomes display at max. feedback and parameter 116 becomes display at min. feedback.
- Connections and set-up are identical to normal control.



External Manual Control Over-ride

For the VLT Series 3500 special parameters are available for external manual over-ride. Refer to parameter group 4 of this instruction manual.

Index

| | | | |
|-------------------------------------------------|------------|-----------------------------------|----------------------|
| + KEY | 48 | Bit 06 | 101 |
| - KEY | 48 | bottom conduit entry plate | 26 |
| 0 to 10 V DC | 83 | bottom cover | 26 |
| 0 to 20 mA | 81, 82, 84 | broken belt | 69 |
| 1 to 5 V DC | 83 | bus | 95 |
| 10 to 0 V DC | 83 | bus Jog | 96 |
| 10 to 2 V DC | 83 | bus references | 79 |
| "2-wire" control | 77 | Byte 1 | 86 |
| 20 to 0 mA | 84 | Byte 13 | 86 |
| 20 to 4 mA | 84 | Byte 14 through 18 | 86 |
| 2 to 10 V DC | 83 | Byte 19 | 86 |
| 24 V Fault | 102 | Byte 2 | 86 |
| "3-wire" control | 77 | Byte 20 and 21 | 86 |
| 4 to 20 mA | 81, 82, 84 | Byte 22 | 86 |
| 5 to 1 V DC | 83 | Byte 3 | 86 |
| | | Byte 4 | 86 |
| | | Byte 5 through 8 | 86 |
| | | Byte 9 through 12 | 86 |
| A | | C | |
| AC line input | 27 | control | 86 |
| accel time | 69 | cable clamp | 26 |
| accelerating | 101 | catch a rotating motor | 72 |
| acceleration time | 69 | catch-up/slow-down | 96 |
| acoustic noise | 70 | CATCH SLOW | 96 |
| active menu setup | 96 | choice of digital reference | 80, 96 |
| additional motor protection | 30 | choice of setup | 80 |
| Adjustable Switching Frequency Modulation | 70 | closed loop | 62, 64 |
| AEO | 62 | coast | 78 |
| air circulation | 23 | COAST/ENABLED | 90 |
| ALARM | 81, 82, 83 | "Coasting Stop" | 101 |
| alarm messages | 103 | conduit entries | 26 |
| alarm mode | 50 | conduit entry | 26 |
| ALARM or WARN | 81, 82, 83 | constant torque | 62 |
| alternative ramp time | 78 | CONTROL CARD FAULT | 104 |
| alternative ramp-up | 79 | control card terminals | 32 |
| ambient temperature | 104 | control card test | 99 |
| analog current | 79 | control inputs | 28 |
| analog input 53 | 63 | control of the torque | 63 |
| analog input 60 | 63 | control panel | 44, 45, 48 |
| analog input references | 84 | control panel keys | 48 |
| analog inputs | 94 | CONTROL READY | 81, 82, 83 |
| analog reference signal | 83 | control wires | 26 |
| analog speed reference | 77 | control wiring | 34 |
| analog voltage | 79 | control word | 87, 86, 87 |
| antistatic packing | 105 | CONTROLS NOT READY / READY | 90 |
| ASFM | 70, 71 | cooling | 25 |
| auto restart | 60 | copying setups | 61 |
| automatic derating | 70 | critical temperature | 104 |
| Automatic Energy Optimizing | 62 | CTRL CARD TEST | 99 |
| automatic fault reset | 73 | current | 84 |
| automatic reset | 73 | CURRENT A | 100 |
| automatic restart | 103 | current control | 84 |
| auxiliary enclosures | 24 | CURRENT LIMIT | 81, 82, 83, 102, 103 |
| | | current limit | 63, 71, 81 |
| | | current limit trips | 69 |
| B | | CURRENT OK/OVERSHOOT | 90 |
| base | 24 | current reference | 32 |
| baud rate | 93 | cutoff frequency | 66 |
| Bit 01 | 101 | | |
| Bit 02 | 101 | | |
| Bit 05 | 101 | | |

D

| | |
|--------------------------------|---------------------|
| dampening | 66 |
| DATA KEY | 48 |
| data log | 97 |
| data mode | 48 |
| DC braking | 73, 78 |
| DC braking voltage | 73 |
| DC BUS V | 100 |
| DC bus voltage | 82, 103 |
| DC voltage | 97, 100 |
| decel ramp | 78 |
| decelerating | 101 |
| deceleration time | 69 |
| default setting | 31 |
| derate | 71 |
| DIG SPD TYPE | 96 |
| digital | 95 |
| DIGITAL INPUT | 100 |
| digital input terminals | 32 |
| digital inputs | 97 |
| digital reference | 79 |
| digital references | 79, 94 |
| digital speed references | 80 |
| dimensional drawings | 26 |
| dimensions | 26 |
| direction of rotation | 67, 79 |
| display | 45, 65 |
| display flashes | 48 |
| Display Mode | 47, 48, 49, 54, 100 |
| distance between drives | 27 |
| DO NOT COPY | 58 |
| DOES NOT RUN/RUNS | 90 |
| door | 26 |
| DRIVE NOT READY / READY | 90 |
| drive setup | 52 |
| dual function display | 100 |

E

| | |
|----------------------------------------------|-----------------------|
| EEPROM | 54 |
| EEPROM ERROR | 102 |
| EEPROM Fault | 102 |
| electrical installation | 27 |
| electrical noise | 33 |
| electronic motor thermal overload | 82 |
| electronic thermal inverter protection | 103 |
| electronic thermal overload protection | 104 |
| electronic thermal relay | 27, 30 |
| electrostatic discharges | 105 |
| EMI | 26, 33 |
| EMI filter | 33, 34 |
| ENABLED noWR | 81, 82, 83 |
| ENERGY kWh | 100 |
| error | 66 |
| ESD service kit | 105 |
| ETR | 27, 64, 102, 103, 104 |
| ETR (MOT) % | 100 |
| ETR (VLT) % | 100 |
| except | 26 |
| EXT. DISPLAY | 100 |
| Extended Data Mode | 50 |
| Extended Display | 47, 94 |
| Extended display | 100 |

| | |
|------------------------------------|----------------|
| extended menu | 47, 48, 54 |
| extended menu mode | 49 |
| extended menus | 58 |
| extended parameter mode | 50 |
| external H-O-A | 76, 77, 78, 84 |
| external hand mode | 44 |
| external mounting of display | 109 |
| external on/off | 79 |
| external run/stop | 46 |

F

| | |
|--------------------------------|-----------------|
| factory defaults | 52 |
| fans | 69 |
| fault code | 98 |
| fault messages | 104 |
| feedback | 65, 76 |
| feedback signal | 81 |
| feedback unit | 100 |
| FEEDBK 'UNIT' | 100 |
| flash | 46 |
| floating point control | 39, 80 |
| floor mount | 25, 27 |
| FREEZE | 84, 101 |
| freeze reference | 80 |
| freeze jogging reference | 79 |
| freeze reference | 60, 76, 79, 101 |
| "Freeze Reference" | 101 |
| FREQUENCY Hz | 100 |
| frequency out | 97 |
| functions of the keys | 48 |

G

| | |
|--------------------------------------------|----------|
| GROUND FAULT | 103 |
| ground gault | 103, 104 |
| grounding plate | 28 |
| Group 0 -- Operation and Display | 57, 58 |
| Group 1 -- Load and Motor | 57 |
| Group 1 -- Load and Motors | 62 |
| Group 2 -- References and Limits | 57, 67 |
| Group 3 -- Functions and Timers | 57, 72 |
| Group 4 -- Inputs and Outputs | 57, 76 |
| Group 5 -- Serial Communication | 57 |
| Group 6 -- Service and Diagnostics | 57 |
| Group 600 -- Service and Diagnostics | 97 |

H

| | |
|------------------------------|---------------------|
| HI CURR. WARN | 69, 81, 82, 83, 102 |
| HI FREQ. WARN | 69, 81, 82, 83, 102 |
| high carrier frequency | 71 |
| high current warning | 102 |
| high frequency warning | 102 |
| high voltage warning | 102 |
| hinged door | 26 |
| HOLD. | 101 |
| hollow squares | 46 |
| HOUR COUNT | 60 |
| how to operate | 45 |
| HP power | 100 |
| humidity | 74 |
| hunting | 69 |

I

- I (read index) 86
- increase or decrease the output frequency 46
- information packet 24
- Initialization 99
- INITIALIZE 99
- input fuses 27
- input power wiring 26
- Input status "binary code" 100
- installation 23
- intermittent operation 68
- internal PID 42
- inverse 42
- INVERT FAULT 103
- INVERT TIME 102
- inverter fault 103
- Inverter Overloaded 102, 103

J

- JOG 84
- jog function 70
- JOG REMOTE 101
- jog speed 67, 94
- jog speed reference 77
- jogging 79, 101

K

- KEY DISABLED 104
- KEY HOA w. stp 39
- KEY LOCAL 59
- keypad 45
- "Keypad" 101
- keypad switches 45
- "Keypad with external stop" 101
- kWh 97

L

- latch start 76, 77, 78
- latch start hand 77, 79
- leaving data mode 54
- LIMIT 104
- linear 69, 83
- "live zero" signals 84
- LO CURR WARN 69, 102
- LO CURR. WARN 69, 81, 82, 83, 102
- LO FREQ. WARN 68, 81, 82, 83
- local control 46
- LOCAL CONTROL/BUS CONTROL 90
- "Local" mode 46
- local operation 45, 46
- local operation OK 101
- local ramp operation 101
- local speed command 46, 50
- local stop 101
- "Local/Hand" 77, 79, 101
- LOCAL/HAND KEY 48
- Local/Hand Mode 50
- LOCK OPEN 52, 104
- lockout 52
- logical and 95, 96
- logical or 95, 96

- loss of load 69
- low carrier frequency at low speed 71
- low current warning 102
- low frequency warning 102
- low voltage warning 102

M

- manual initialization 97
- manual reset 73
- MAX 84
- maximum speed 67
- menu access keys 51
- MENU KEY 48
- minimum motor current 71
- minimum motor current value (idle running current) 71
- minimum speed 67, 72
- MOT.THERM.WARN 82, 83
- motor coasting stop 78
- motor current is above the current programmed 81
- motor current is below the current programmed 81
- motor electronic thermal relay 102, 103, 104
- motor noise 71
- motor output 27
- motor overloaded 102, 103
- motor protection 68
- motor temperature 75
- motor therm % 100
- MOTOR TIME 102
- MOTOR TRIP 76, 103, 104
- motor wiring 33, 34
- motor wiring shield 33
- mounting base 23
- mounting bracket 23
- "Mtr. Coast" 101
- multi-setup 58, 76
- multiple motors 62

N

- NEMA 1 26
- NEMA 12 26
- NO 24 VOLT 102
- no auto-restart 38
- NO FAULT/TRIP 90
- no fly start 72
- NO LOAD CURR 82, 83
- NO MOTOR 74, 102
- NO OPERATION 83, 84
- No operation 77
- NO WARNING/WARNING 90
- normal operation 99
- number of overheatings 97
- number of overvoltages 97
- number of power ups 97

O

- Off 2 101
- Off 3 101
- OK/OVER- OR UNDERVOLTAGE 90
- ON2/OFF2 90
- ON3/OFF3 90
- ONLY IN STOP 104
- OPEN LOOP 64

| | | | |
|---------------------------------------------|-----------------------|-----------------------------------------------|--------|
| open loop | 62 | 202 Maximum Frequency | 67 |
| “Open Loop” | 59 | 203 Jog Frequency | 67 |
| operation OK | 101 | 204 Digital Reference Type | 67 |
| operation with deactivated inverter | 99 | 205 Digital Reference 1 | 68 |
| option cards | 109 | 206 Digital Reference 2 | 68 |
| OUT CURR RGE | 81, 82, 83 | 207 Digital Reference 3 | 68 |
| OUT FREQ RGE | 81, 82, 83 | 208 Digital Reference 4 | 68 |
| OUT OF RANGE/FREQUENCY OK | 90 | 209 Current Limit (ILIM) | 68 |
| output current | 81 | 210 Warning: Low Frequency | 68 |
| output signals | 81 | 211 Warning: High Frequency | 69 |
| OUTPUT VOLT.V | 100 | 212 Warning: Low Current, ILOW | 69 |
| output voltage | 100 | 213 Warning: High Current, IHIGH | 69 |
| OVER CURRENT | 102, 103 | 214 Ramp Type | 69 |
| OVER TEMP | 103 | 215 Accel (ramp-up) Time | 69 |
| OVER VOLTAGE | 102, 103 | 216 Decel (ramp-down) Time | 69 |
| overcurrent | 102, 103, 104 | 217 Alternative Accel (ramp up) Time | 70 |
| overcurrent trip | 72 | 218 Alternative Decel (ramp down) Time | 70 |
| OVERLOAD | 103 | 219 Frequency Bypass 1 | 70 |
| overload | 102, 103, 104 | 220 Frequency Bypass 2 | 70 |
| overshoot | 66 | 221 Frequency Bypass 3 | 70 |
| overshooting | 69 | 222 Frequency Bypass 4 | 70 |
| overtemperature | 103 | 223 Frequency Bypass Bandwidth | 70 |
| overvoltage | 69, 74, 102, 103, 104 | 224 Carrier Frequency | 70 |
| overvoltage fault | 69 | 225 Adjust Switching Frequency Modulation ... | 71 |
| P | | | |
| Parallel Connection of Motors | 30 | 232 Idle Running Current | 71 |
| Parameters -- Description and Setting | | 301 Start Frequency | 72 |
| 000 Language | 58 | 302 Delayed Start | 72 |
| 001 Setup Choice, Operation | 58 | 303 High Starting Torque | 72 |
| 002 Copy of Setups | 58 | 305 Catch a Rotating Motor | 72 |
| 003 Local/Remote Control | 59 | 306 DC Braking Time | 73 |
| 004 Local Reference | 59 | 307 DC Brake Cut-in Frequency | 73 |
| 005 User Readout | 59 | 308 DC Brake Voltage | 73 |
| 006 Local Reset | 59 | 309 Reset Function | 73 |
| 007 Local Stop | 59 | 310 Trip Delay at Current Limit | 74 |
| 008 Local/Hand | 59 | 311 Trip Delay at Inverter Fault | 74 |
| 009 Remote/Auto | 60 | 312 Maximum Automatic Restart Time | 74 |
| 010 Local Speed Selection | 60 | 313 Motor Check | 74 |
| 011 Reset of kWh | 60 | 314 Motor Preheat | 74 |
| 012 Reset of Hours Run | 60 | 315 Motor Thermal Protection | 75 |
| 014 Power Up Mode | 60 | 316 Relay ON Delay | 75 |
| 015 Setup Choice, Programming | 61 | 317 Relay OFF Delay | 75 |
| 100 Load | 62 | 400 Terminal 16 Input | 76 |
| 101 Speed Control | 62 | 402 Terminal 18 | 77 |
| 102 Setting of Current Limit | 63 | 403 Terminal 19 | 77, 78 |
| 103 Motor Power | 63 | 404 Terminal 27 Stop | 78 |
| 104 Motor Voltage | 63 | 405 Terminal 29 Input | 79 |
| 105 Motor Frequency | 64 | 406 Terminals 32/33 Input | 80 |
| 107 Motor Current | 64 | 408 Terminal 45 Output | 82 |
| 109 Start Voltage | 64 | 410 Terminal 04 Relay Output | 83 |
| 114 Feedback Signal | 64 | 411 Analog Reference Type | 83 |
| 115 Display Value at Minimum Feedback | 65 | 412 Terminal 53 Analog Input Voltage | 83 |
| 116 Display Value at Maximum Feedback | 65 | 413 Terminal 60 Analog Input Current | 84 |
| 117 Display Unit | 65 | 414 Time Out Interval | 84 |
| 119 FF Factor | 65 | 415 Time Out Interval Function | 84 |
| 120 Control Range | 66 | 420 Reference Type to H-O-A | 84 |
| 121 Proportional Gain | 66 | 500 Address | 93 |
| 122 Integral Time | 66 | 501 Bits/Sec. Baud Rate | 93 |
| 123 Differential Time | 66 | 502 Data Readout | 93 |
| 124 Lowpass Filter | 66 | 503 Coasting | 95 |
| 125 Feedback Factor | 66 | 504 Quick-Stop | 95 |
| 201 Minimum Frequency | 67 | 505 DC Brake | 95 |
| | | 506 Start | 95 |
| | | 507 Direction of Rotation | 95 |

| | | | |
|------------------------------------|------------------------------|---------------------------------------|--------------------------------------------|
| 508 Reset | 95 | parameter 224 | 71 |
| 509 Selection of Setup | 95 | parameter 225 | 70 |
| 510 Selection of Speed | 95, 96 | parameter 301 | 72 |
| 511 Bus Jogging 1 | 96 | parameter 306 | 72, 78 |
| 512 Bus Jogging 2 | 96 | parameter 307 | 78 |
| 513 Catch-up/Slow-down Value | 96 | parameter 308 | 78 |
| 514 Bus Bit 4 | 96 | parameter 309 | 103 |
| 516 Bus Reference | 96 | parameter 310 | 68, 102, 103 |
| 517 Save Data Values | 96 | parameter 311 | 29, 102 |
| 600 Operation Data | 97 | parameter 312 | 73, 103 |
| 601 Data Log | 97 | parameter 315 | 29, 52, 103, 104 |
| 602 Alarm Store | 98 | parameter 316 | 75, 82 |
| 603 Nameplate | 98 | parameter 317 | 75, 82 |
| 604 Operation Mode | 99 | parameter 400 | 44, 58, 59, 60, 76, 78, 79, 80, 104 |
| 606 Display Mode | 100 | parameter 401 | 44, 58, 59, 60, 64, 76, 78, 79, 80, 81, 84 |
| Parameters--other references | | parameter 402 | 44, 59, 60, 76, 78 |
| parameter 001 | 52, 61 | parameter 403 | 44, 59 |
| parameter 002 | 52, 58, 61 | parameter 404 | 44, 59, 70, 73, 101 |
| parameter 003 | 44, 84, 101 | parameter 405 | 59, 60, 67, 70 |
| parameter 004 | 59, 60 | parameter 406 | 58, 60, 68, 76, 80, 84 |
| parameter 006 | 48, 52 | parameter 407 | 68, 69, 83 |
| parameter 007 | 48, 52, 59 | parameter 408 | 68, 69 |
| parameter 008 | 46, 48, 52 | parameter 409 | 32, 54, 68, 69, 75, 83 |
| parameter 009 | 48, 52 | parameter 410 | 32, 68, 69 |
| parameter 010 | 52, 59 | parameter 412 | 32, 63, 64, 79, 81, 84 |
| parameter 011 | 97 | parameter 413 | 32, 63, 64, 79, 81, 84 |
| parameter 012 | 97 | parameter 414 | 84 |
| parameter 014 | 59, 80 | parameter 415 | 84 |
| parameter 015 | 58 | parameter 420 | 44, 59, 76, 78 |
| parameter 100 | 64 | parameter 497 | 96 |
| parameter 101 | 59, 64, 76 | parameter 500 | 93 |
| parameter 102 | 84 | parameter 501 | 52 |
| parameter 103 | 81 | parameter 502 | 93 |
| parameter 107 | 63, 29, 75 | parameter 503 | 95, 96 |
| parameter 109 | 62, 63 | parameter 504 | 95 |
| parameter 117 | 59 | parameter 505 | 95 |
| parameter 119 | 62 | parameter 516 | 79 |
| parameter 120 | 62 | parameter 517 | 96 |
| parameter 121 | 62 | parameter 604 | 52 |
| parameter 122 | 62 | parameter 605 | 47 |
| parameter 124 | 62 | parameter 606 | 47 |
| parameter 125 | 62 | parameter 650 | 63 |
| parameter 201 | 67, 68 | parameter groups | 54 |
| parameter 202 | 59, 62, 67, 68, 71, 80 | PC | 93 |
| parameter 203 | 79, 94, 96 | peak current limit | 103 |
| parameter 204 | 79 | phase current | 97 |
| parameter 205 | 79, 80, 94 | PID controller | 41, 47, 62, 64, 65, 66, 84 |
| parameter 206 | 79, 80, 94 | PLC | 93 |
| parameter 207 | 79, 80, 94 | potentiometer | 32, 35 |
| parameter 208 | 79, 80, 81, 94 | POWER HP | 100 |
| parameter 209 | 63, 71, 72, 74, 81, 102, 103 | POWER kW | 100 |
| parameter 210 | 102 | power outage | 77 |
| parameter 211 | 82 | power-out situation | 72 |
| parameter 212 | 71, 102 | preset speed(s) | 40, 67, 80 |
| parameter 213 | 102 | Profibus communication | 52 |
| parameter 215 | 77, 80 | program parameters | 45 |
| parameter 216 | 76, 77, 78, 80 | programmable terminal functions | 31 |
| parameter 217 | 79 | programming | 45, 47, 58 |
| parameter 218 | 78 | proportional | 83 |
| parameter 219 | 70 | pulse input | 76 |
| parameter 220 | 70 | pulse signals | 76 |
| parameter 221 | 70 | pulse start | 43, 80 |
| parameter 222 | 70 | | |

pulse start hand 76
 pulses 79
 pumps 69

Q

QUICK DISPLAY 100
 Quick Setup data mode 49
 Quick Setup menu 49
 Quick Setup 47, 48, 52
 quick-stop 70, 78, 79, 96

R

R (read) 86
 radio noise 26
 ramp down 72
 RAMP LOCAL 101
 ramp selection 79
 ramp time(s) 70, 79
 RAMPING 101
 ramps 69
 rated motor current 68
 rated motor frequency 64
 RDY+DC V OK 82, 83
 RDY+MOT+REM 82, 83
 READY+MOT.OK 82, 83
 REF FAULT 84, 102
 REFERENCE % 94, 100
 reference % 97, 100
 reference Fault 102
 reference for manual operation 84
 reference Locked 101
 reference signal 64
 relay 01 44, 71
 relay 04 71
 relay output 32
 relay output 01 75, 82
 relay output 04 82
 remote control mode 82, 101
 remote Hand/Off/Auto 43
 remote indication of motor speed 36
 remote indication of output current 38
 remote mounting 45
 remote operation 46
 "Remote/Auto" 46, 101
 REMOTE/AUTO KEY 48
 reset 46, 76
 reset and motor coasting stop 78
 reset key 103
 reset messages 103
 resonance 70
 RESTART 103
 return to factory defaults 52
 reverse 36, 77
 reverse direction 77
 reversing 67
 RFI 26, 33
 row of dashes 46
 RUN HOURS 100
 RUN INV DISABL 99
 RUN NORMAL 99
 RUN OK LOCAL 101
 RUN OK 101

RUN@REF noWR 81, 82, 83
 RUNinRANGE 81, 82, 83
 RUNNING 81, 82, 83
 running above the frequency 81
 running below the frequency 81
 running hours 97, 100
 RUNNING noWR 81, 82, 83
 running out of the current range 81
 running out of the frequency range 81

S

safety interlock(s) 35, 36
 safety regulations 27
 scale 66
 second line in display 46
 selection of setup 76
 serial bus 93
 serial communication 34, 77
 serial communication parameters 93
 serial interface 103
 setpoint 76
 setup 76
 setups 47
 shield 26, 27
 shielded cable 26
 shielded motor cables 33
 signal outputs 75
 sine shape 69
 sine² shape 69
 sine³ shape 69
 software type 98
 software version 98
 SPEED REF/SPEED = REF 90
 speed reference 46, 76, 94
 speed reference value 79
 speed up and down 39
 speed up/down 80, 84
 STANDARD DISP 100
 standard display 47, 100
 start 72, 77
 start disabled 101
 START ENABLED/NOT ENABLED 90
 "start forward" switch 77
 start in reverse direction 77
 START INHIB 101
 START KEY 48
 start not possible 73
 "start reverse" switch 77
 start signal 44
 start-up test 104
 start/stop 77
 starting current 72
 starting into a rotating motor 72
 starting up 46
 static electricity 105
 status messages 101
 status word 89, 97
 STOP 84
 stop 46, 76, 77, 78, 101
 "Stop" 101
 STOP LOCAL 101
 STOP REMOTE 101
 "Stop/Reset" 79

| | |
|------------------------|-----|
| STOP/RESET KEY | 48 |
| strain relief | 26 |
| supply voltage | 32 |
| switch pin 01 | 104 |
| switch pin 01 | 52 |
| system stability | 69 |

T

| | |
|---------------------------------------|----------------------------------|
| terminal 01 | 82 |
| terminal 02 | 82 |
| terminal 03 | 82 |
| terminal 12 | 32, 54, 76, 77, 78, 79, 80 |
| terminal 16 | 44, 73, 76, 78, 80, 103, 104 |
| terminal 17 | 44, 64, 76, 80, 81, 84, 103 |
| terminal 18 | 44, 77 |
| terminal 19 | 44, 67, 76, 77, 78 |
| terminal 20 | 32, 76 |
| terminal 27 | 59, 70, 73, 74, 78, 96, 101, 103 |
| terminal 29 | 44, 67, 70, 76, 79, 80 |
| terminal 32 | 68, 76, 79, 80, 96 |
| terminal 33 | 68, 76, 79, 80, 96 |
| terminal 38 | 32 |
| terminal 39 | 32 |
| terminal 42 | 81 |
| terminal 45 | 81 |
| terminal 50 | 32 |
| terminal 50 | 76, 104 |
| terminal 53 | 32, 64, 81, 94 |
| terminal 55 | 32 |
| terminal 60 | 32, 54, 81, 94 |
| terminal 61 | 32 |
| terminal block locations | 31 |
| terminals | 32 |
| terminals 01 and 03 | 32 |
| terminals 04 and 05 | 32 |
| terminals 16 | 44 |
| terminals 16 and 33 | 32 |
| terminals 32 | 79 |
| terminals 42 and 45 | 32 |
| terminals 53 | 94 |
| terminals 68 and 69 | 32 |
| test connector | 99 |
| thermal motor protection | 64 |
| thermal switch | 76 |
| thermistor | 32, 37, 76 |
| three-wire "Start/Stop" | 38 |
| time delay | 84, 103 |
| TIMERS OK/OVERSHOOT | 91 |
| TORQUE % | 100 |
| total number of operating hours | 97 |
| total speed reference | 81 |
| TRIP | 50, 103 |
| Trip | 75, 103 |
| TRIP LOCK | 50, 103 |
| troubleshooting | 106 |

U

| | |
|-------------------------|-------------------|
| U (update) | 86 |
| UL | 26 |
| uncontrolled stop | 72 |
| UNDER VOLTAGE | 102, 103 |
| undervoltage | 74, 102, 103, 104 |

| | |
|------------------------------|-----------------|
| UNIT RDY LOC | 101 |
| UNIT READY | 81, 82, 83, 101 |
| unshielded motor wires | 33 |
| unstable | 66 |
| UNT RDY RCTL | 81, 82, 83 |

V

| | |
|--------------------------------|-----|
| variable torque | 62 |
| VLT OK/STALLS, AUTOSTART | 90 |
| VLT ready | 101 |
| VLT ready, local | 101 |
| VLT therm % | 100 |
| voltage | 84 |
| VOLTAGE HIGH | 102 |
| VOLTAGE LOW | 102 |
| voltage reference | 32 |

W

| | |
|---------------------------|--------|
| wall mount | 23, 25 |
| warning | 68, 69 |
| warning current low | 71 |
| warning messages | 102 |



**Danfoss Electronic Drives
Division of Danfoss Inc.**

2995 Eastrock Drive Rockford, Illinois 61109
815-398-2770 FAX 815-398-2869

Danfoss can accept no responsibility for possible errors in catalogs, brochures and other printed material. Danfoss reserves the right to alter its products without notice. This also applies to products already on order provided that such alterations can be made without subsequential changes being necessary in specifications already agreed.